BUNN®

SLCA-7



ILLUSTRATED PARTS CATALOG

Designs, materials, weights, specifications, and dimensions for equipment or replacement parts are subject to change without notice.

BUNN-O-MATIC CORPORATION

POST OFFICE BOX 3227

SPRINGFIELD, ILLINOIS 62708-3227

PHONE: (217) 529-6601 FAX: (217) 529-6644

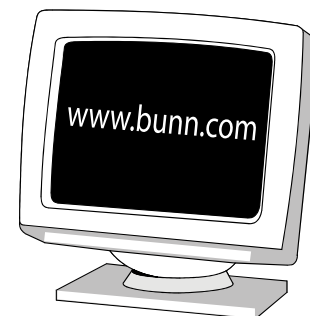

BUNN-O-MATIC COMMERCIAL PRODUCT WARRANTY

Bunn-O-Matic Corp. ("BUNN") warrants equipment manufactured by it as follows:

- 1) Airpots, thermal carafes, decanters, GPR servers, iced tea/coffee dispensers, MCP/MCA pod brewers thermal servers and Thermofresh servers (mechanical and digital)- 1 year parts and 1 year labor.
- 2) All other equipment - 2 years parts and 1 year labor plus added warranties as specified below:
 - a) Electronic circuit and/or control boards - parts and labor for 3 years.
 - b) Compressors on refrigeration equipment - 5 years parts and 1 year labor.
 - c) Grinding burrs on coffee grinding equipment to grind coffee to meet original factory screen sieve analysis - parts and labor for 4 years or 40,000 pounds of coffee, whichever comes first.

These warranty periods run from the date of installation BUNN warrants that the equipment manufactured by it will be commercially free of defects in material and workmanship existing at the time of manufacture and appearing within the applicable warranty period. This warranty does not apply to any equipment, component or part that was not manufactured by BUNN or that, in BUNN's judgment, has been affected by misuse, neglect, alteration, improper installation or operation, improper maintenance or repair, non periodic cleaning and descaling, equipment failures related to poor water quality, damage or casualty. In addition, the warranty does not apply to replacement of items subject to normal use including but not limited to user replaceable parts such as seals and gaskets. This warranty is conditioned on the Buyer 1) giving BUNN prompt notice of any claim to be made under this warranty by telephone at (217) 529-6601 or by writing to Post Office Box 3227, Springfield, Illinois 62708-3227; 2) if requested by BUNN, shipping the defective equipment prepaid to an authorized BUNN service location; and 3) receiving prior authorization from BUNN that the defective equipment is under warranty.

THE FOREGOING WARRANTY IS EXCLUSIVE AND IS IN LIEU OF ANY OTHER WARRANTY, WRITTEN OR ORAL, EXPRESS OR IMPLIED, INCLUDING, BUT NOT LIMITED TO, ANY IMPLIED WARRANTY OF EITHER MERCHANTABILITY OR FITNESS FOR A PARTICULAR PURPOSE. The agents, dealers or employees of BUNN are not authorized to make modifications to this warranty or to make additional warranties that are binding on BUNN. Accordingly, statements by such individuals, whether oral or written, do not constitute warranties and should not be relied upon.

If BUNN determines in its sole discretion that the equipment does not conform to the warranty, BUNN, at its exclusive option while the equipment is under warranty, shall either 1) provide at no charge replacement parts and/or labor (during the applicable parts and labor warranty periods specified above) to repair the defective components, provided that this repair is done by a BUNN Authorized Service Representative; or 2) shall replace the equipment or refund the purchase price for the equipment.

THE BUYER'S REMEDY AGAINST BUNN FOR THE BREACH OF ANY OBLIGATION ARISING OUT OF THE SALE OF THIS EQUIPMENT, WHETHER DERIVED FROM WARRANTY OR OTHERWISE, SHALL BE LIMITED, AT BUNN'S SOLE OPTION AS SPECIFIED HEREIN, TO REPAIR, REPLACEMENT OR REFUND.

In no event shall BUNN be liable for any other damage or loss, including, but not limited to, lost profits, lost sales, loss of use of equipment, claims of Buyer's customers, cost of capital, cost of down time, cost of substitute equipment, facilities or services, or any other special, incidental or consequential damages.

392, A Partner You Can Count On, Air Infusion, AutoPOD, AXIOM, BrewLOGIC, BrewMETER, Brew Better Not Bitter, BrewWISE, BrewWIZARD, BUNN Espresso, BUNN Family Gourmet, BUNN Gourmet, BUNN Pour-O-Matic, BUNN, BUNN with the stylized red line, BUNNlink, Bunn-O-Matic, Bunn-O-Matic, BUNNserve, BUNNSERVE with the stylized wrench design, Cool Froth, DBC, Dr. Brew stylized Dr. design, Dual, Easy Pour, EasyClear, EasyGard, FlavorGard, Gourmet Ice, Gourmet Juice, High Intensity, iMIX, Infusion Series, Intellisteam, My Café, Phase Brew, PowerLogic, Quality Beverage Equipment Worldwide, Respect Earth, Respect Earth with the stylized leaf and coffee cherry design, Safety-Fresh, savemycoffee.com, Scale-Pro, Silver Series, Single, Smart Funnel, Smart Hopper, SmartWAVE, Soft Heat, SplashGard, The Mark of Quality in Beverage Equipment Worldwide, ThermoFresh, Titan, trifecta, Velocity Brew, Air Brew, Beverage Bar Creator, Beverage Profit Calculator, Brew better, not bitter., BUNNSource, Coffee At Its Best, Cyclonic Heating System, Daypart, Digital Brewer Control, Element, Nothing Brews Like a BUNN, Pouring Profits, Signature Series, Tea At Its Best, The Horizontal Red Line, Ultra are either trademarks or registered trademarks of Bunn-O-Matic Corporation. The commercial trifecta® brewer housing configuration is a trademark of Bunn-O-Matic Corporation.

TABLE OF CONTENTS

Covers, Panels & Drip Tray	4
Door Assembly	8
Pump & Tubing	10
Cooling Fan & Air Duct.....	12
Pump Assembly.....	14
Water Inlet & Tank Drain	16
Tank Assembly	18
Dispense Valve and Lines.....	20
Auger Drive & Hopper Assy	22
Mixing/Whipper Chamber & Drive Motor.....	24
Electrical Components	28
Numerical Index.....	30

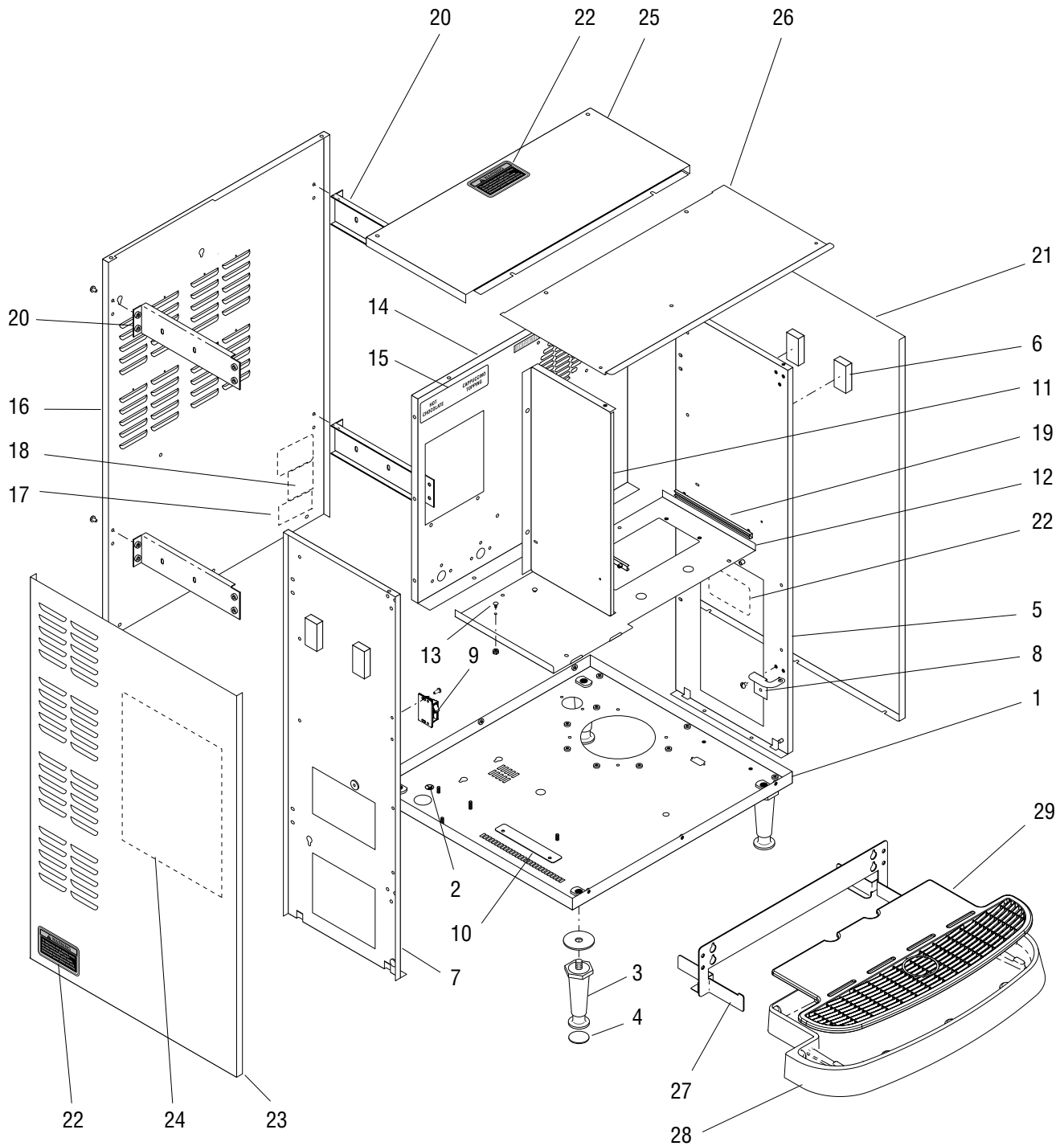

COVERS, PANELS AND DRIP TRAY

ITEM	PART NO.	QTY.	DESCRIPTION
1	38664.1003	1	Base w/Decals (Includes item 2)
2	00824.0002	1	Decal, Grounding Location
3	26528.0000	4	Leg, 4.0" Adjustable
	01526.0001	4	Washer
4	03996.0000	4	Pad, Anti Skid
5	38080.0001	1	Panel, Inner Right
	01311.0001	5	Screw, Truss Head Locking #8-32 x .25"
6	36896.0000	4	Pad
7	38082.0000*	1	Panel, Inner Left
	01311.0001	5	Screw, Truss Head Locking #8-32 x .25"
8	36647.0001	1	Bracket, Hinge, Lower Right
	01311.0001	3	Screw, Truss Head Locking #8-32 x .25"
9	34666.0000	1	Catch, Door latch
	02336.0000	2	Screw, Truss Head #4-40 x .38"
	01509.0001	2	Lockwasher, Internal-tooth #4
10	39284.0000	1	Plate, Retainer
11	45389.0000	1	Panel, Center
	01311.0001	4	Screw, Truss Head Locking #8-32 x .25"
12	38084.0003	1	Platform, Hopper Mounting
	01311.0000	4	Screw, Truss Head #8-32 x .25"
13	20960.0000	2	Shoulder Screw
	00991.0002	2	Nut, Lock #6-32
14	38077.1006	1	Panel w/Decals, Inner Rear (Includes item 15)
15	39583.0000	1	Decal, Hopper Placement
16	38990.1001	1	Panel w/Decals, Rear (Includes items 17 & 18)
	01311.0003	11	Screw, Truss Head BLK #8-32 x .25"
17	00986.0000	1	Decal, Warning Electrical
18	00656.0001	1	Decal, Comply to Plumbing
19	26008.0001	2	Mount, Card Snap-In
20	35926.0000	4	Bracket, Side Support
	01311.0001	8	Screw, Truss Head Locking #8-32 x .25"
21	35912.1001	1	Panel w/Decals, Right Side (Includes item 22)
	01311.0003	3	Screw, Truss Head BLK #8-32 x .25"
22	37881.0000	3	Decal, No Serviceable Parts
23	35912.1004	1	Panel w/Decals, Left Side (Includes items 22 & 24)
	01311.0003	3	Screw, Truss Head BLK #8-32 x .25"
24	39318.0008	1	Schematic, Electrical
25	35916.1002	1	Panel w/Decals, Top Rear (Includes item 22)
	01311.0003	2	Screw, Truss Head BLK #8-32 x .25"

(Continued)

* Indicates the part number listed is for reference only. See DESCRIPTION for possible service replacement.

(Continued)

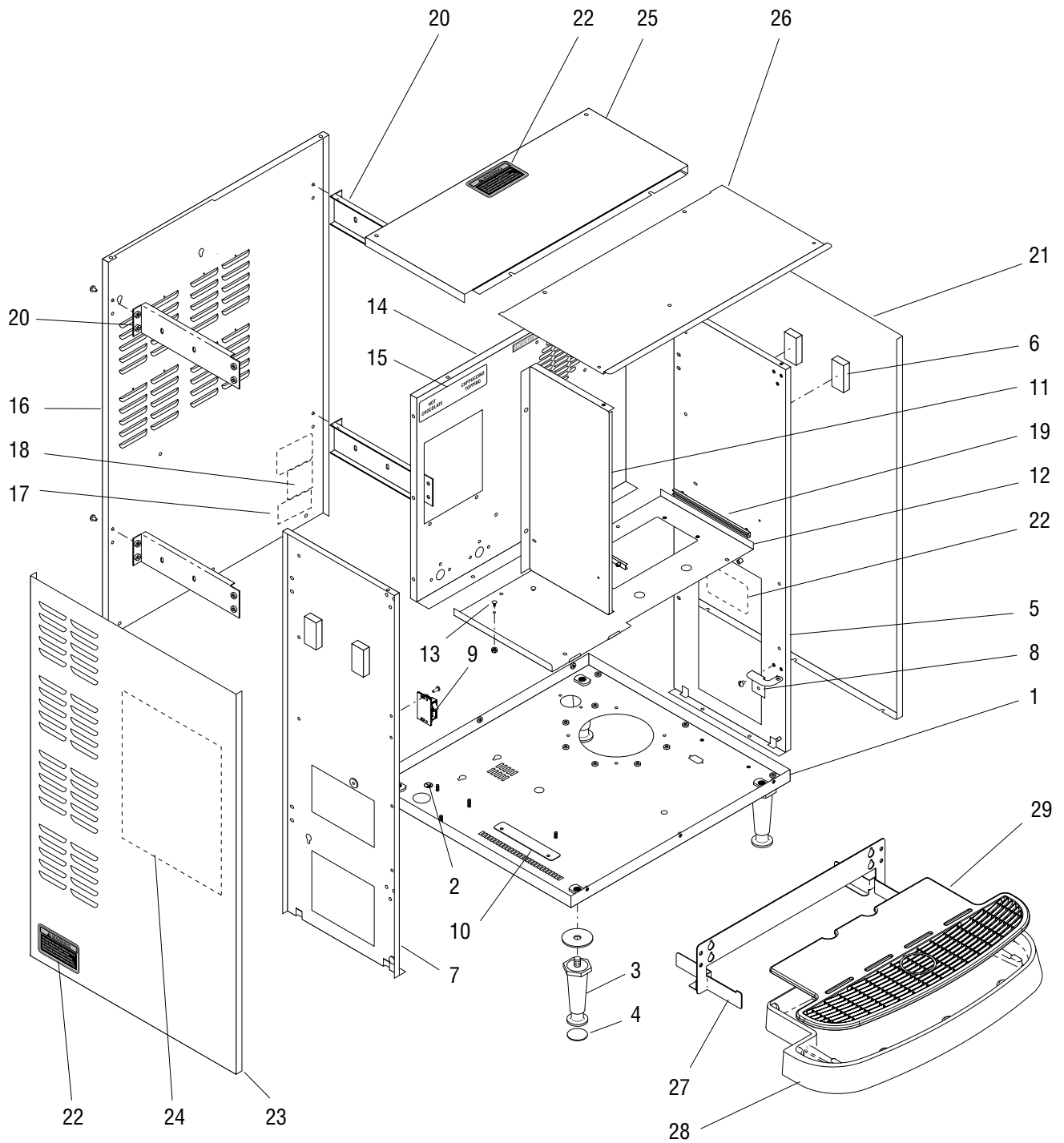

COVERS, PANELS AND DRIP TRAY

ITEM	PART NO.	QTY.	DESCRIPTION
26	35915.1002	1	Panel, Top Front
	01382.0002	2	Screw, Truss Head BLK #6-32 x .38"
	01311.0003	3	Screw, Truss Head BLK #8-32 x .25"
27	37065.0001	1	Bracket, Drip Tray
28	36670.0000	1	Drip Tray Assy
29	39308.0000	1	Cover, Drip Tray

* Indicates the part number listed is for reference only. See DESCRIPTION for possible service replacement.

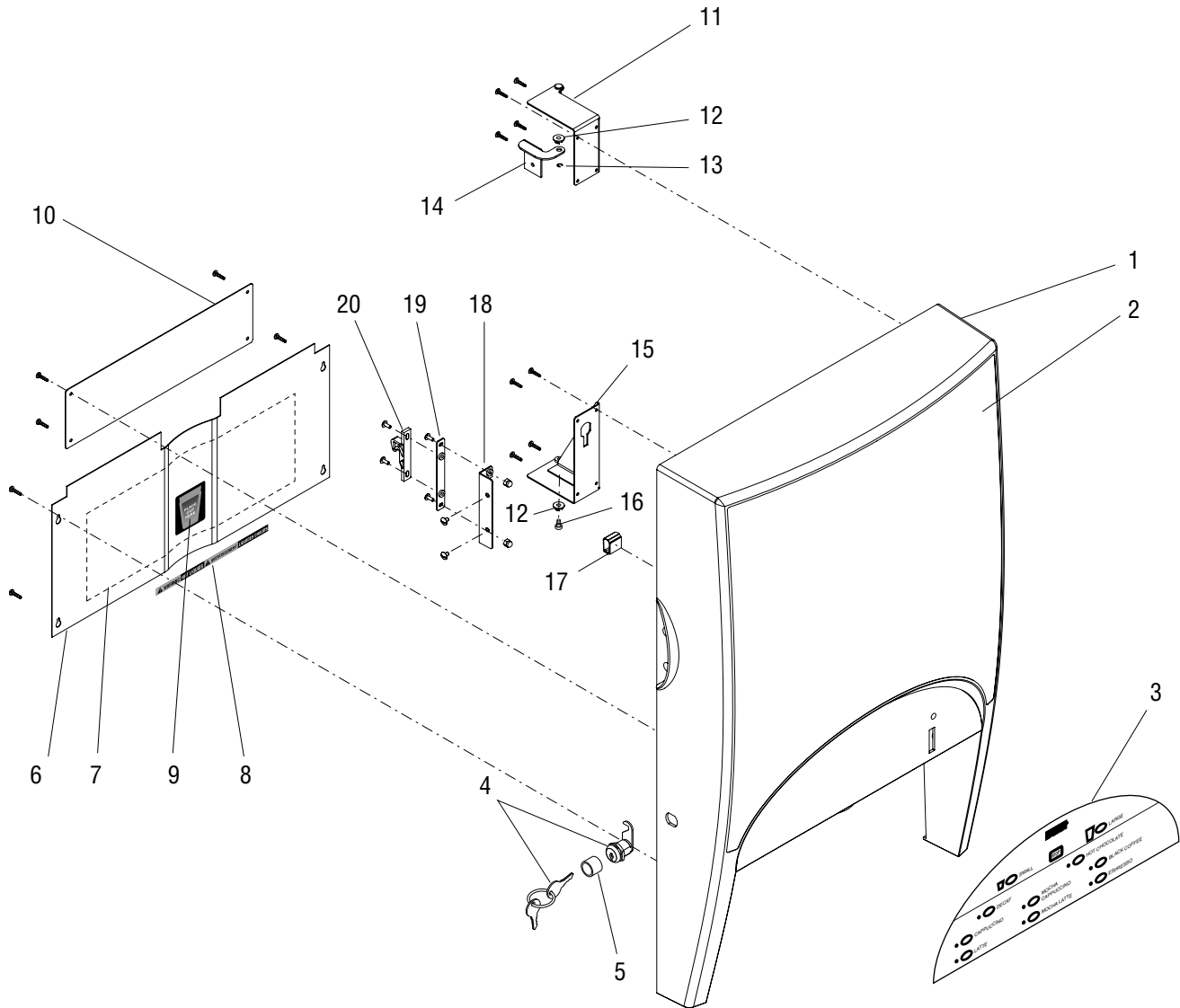

DOOR ASSEMBLY

ITEM	PART NO.	QTY.	DESCRIPTION
-	39041.1004	1	Door Assembly (Includes items 1 - 20)
1	38933.0000	1	Door
2	39167.0003	1	Decal, Door
3	39258.0007	1	Membrane Switch
4	34472.1001	1	Lock Assy (Includes Keys)
	28095.0000	1	Keys (Set of 2)
5	35052.1002	1	Tube, Silicone
6	39030.0000	1	Splash Panel
	44646.0001	4	Screw, Pan Head #6 x .60"
7	39479.0000	1	Decal, Cleaning
8	11646.0002	1	Decal, Warning - Hot Liquids
9	39474.0000	1	Decal, Cup Placement
10	39040.1000	1	Panel, Inner Access (Includes item 21)
	44646.0001	4	Screw, Pan Head #6 x .60"
11	39034.0000	1	Bracket, Upper Door
	44646.0001	4	Screw, Pan Head #6 x .60"
12	34362.0000	2	Bushing
13	01403.0000	1	E-ring
14	36647.0001	1	Bracket, Hinge
	01311.0001	3	Screw, Truss Head Locking #8-32 x .25"
15	39033.0000	1	Bracket, Lower Door
	44646.0001	4	Screw, Pan Head #6 x .60"
16	24457.0002	1	Screw, Shoulder
17	35260.0000	1	Cable Mount (Door Cable)
18	39036.0000	1	Bracket, Latch
	44646.0001	2	Screw, Pan Head #6 x .60"
	01347.0000	2	Screw, Truss Head #6-32 x .38"
	24224.0000	2	Nut, Acorn #6-32
19	39038.0000	1	Plate, Latch
	01347.0000	2	Screw, Truss Head #6-32 x .38"
20	34667.0000	1	Keeper, Door Latch
	01311.0005	2	Screw, Truss Head BLK #8-32 x .38"

* Indicates the part number listed is for reference only. See DESCRIPTION for possible service replacement.

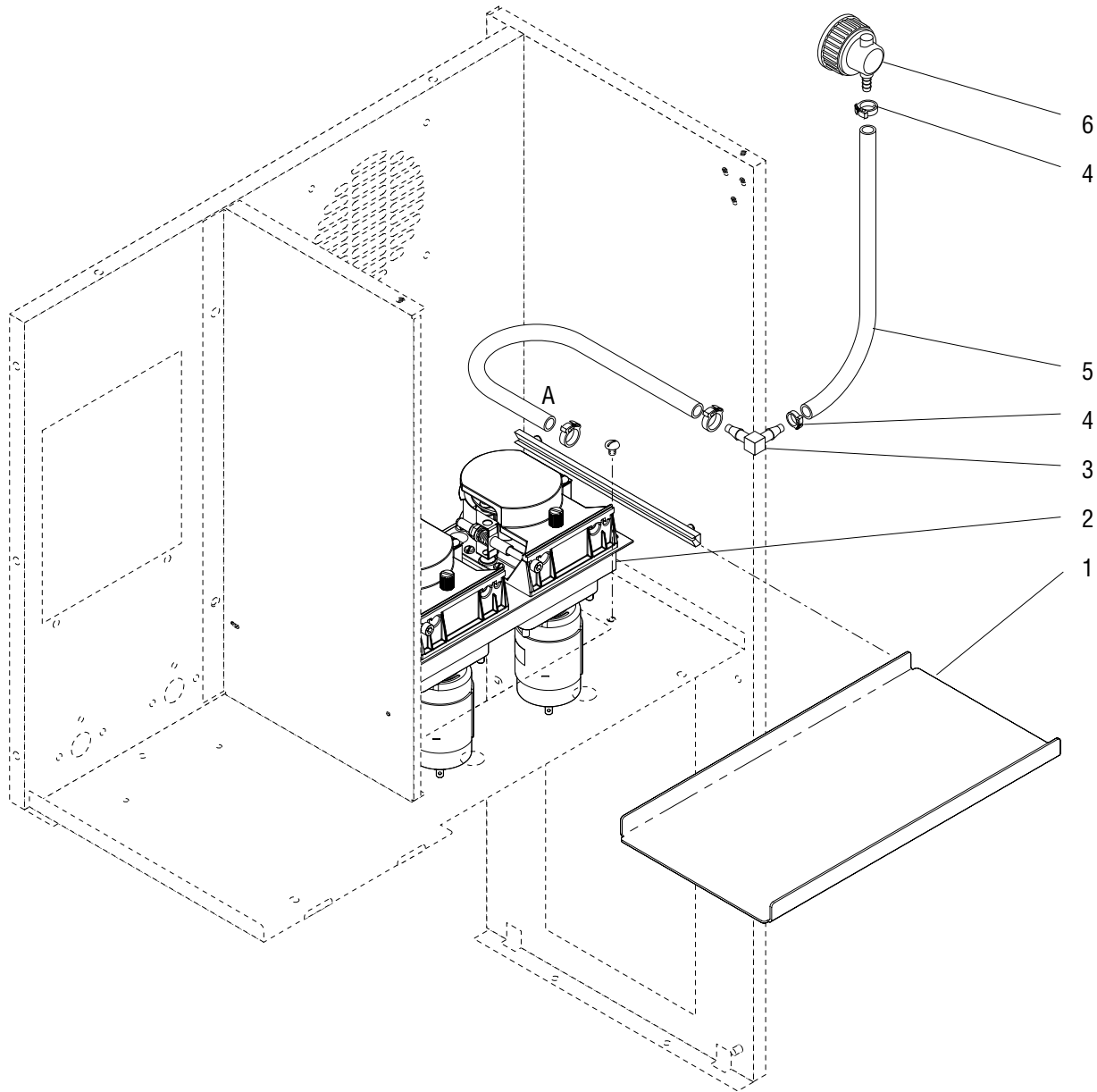

NOTE: Letters appearing within this illustration correspond to matching connections in other illustrations.

P4327.75

PUMP & TUBING

ITEM	PART NO.	QTY.	DESCRIPTION
1	45391.0000	1	Panel, BIB Support
2	----- 01311.0001	1 4	Pump Assy. (See PUMP ASSEMBLY) Screw, Truss Head #8-32 x .25" Lkg
3	34714.0000	2	Elbow, Sngl Barb
4	12422.0003	8	Clamp, Hose .34 - .39"
5	34729.0003	4	Tube, Norprene .187" ID x 9.13"
6	35057.0000	2	Connector, BIB
7	37500.0206	-	Tube Kit (Includes items 3 - 6)

* Indicates the part number listed is for reference only. See DESCRIPTION for possible service replacement.

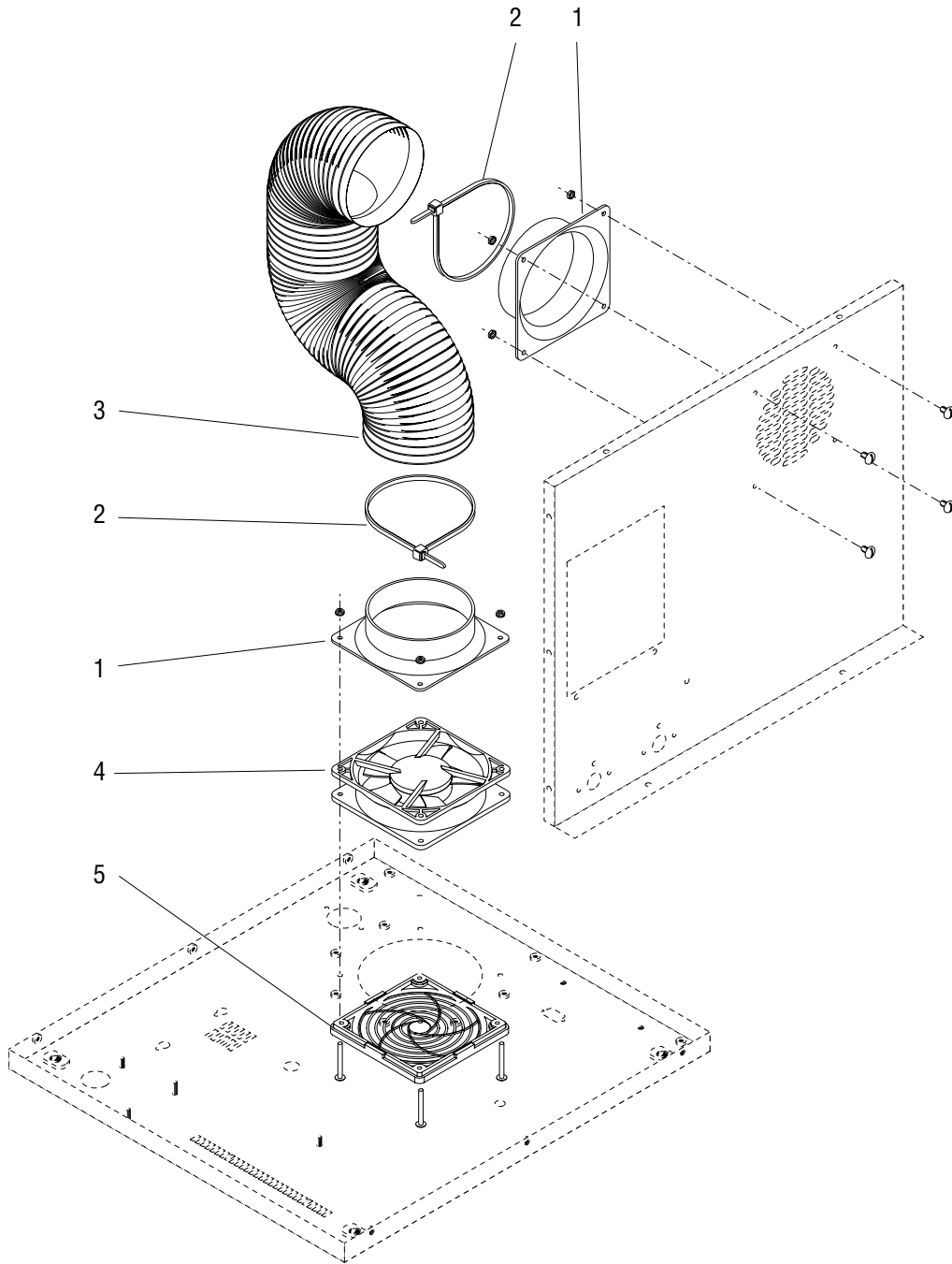

COOLING FAN & DUCT

ITEM	PART NO.	QTY.	DESCRIPTION
1	38808.0000	2	Adapter
	00970.0000	8	Nut, Keps #8-32
	01315.0000	4	Screw, Truss Head #8-32 x .38"
2	32734.0000	2	Tie, Cable
3	38811.0000	1	Duct, 4.0"
4	33297.0002	1	Fan Assy
	01384.0002	4	Screw, Truss Head #8-32 x 2.0"
5	41415.0000	1	Fan Guard

* Indicates the part number listed is for reference only. See DESCRIPTION for possible service replacement.

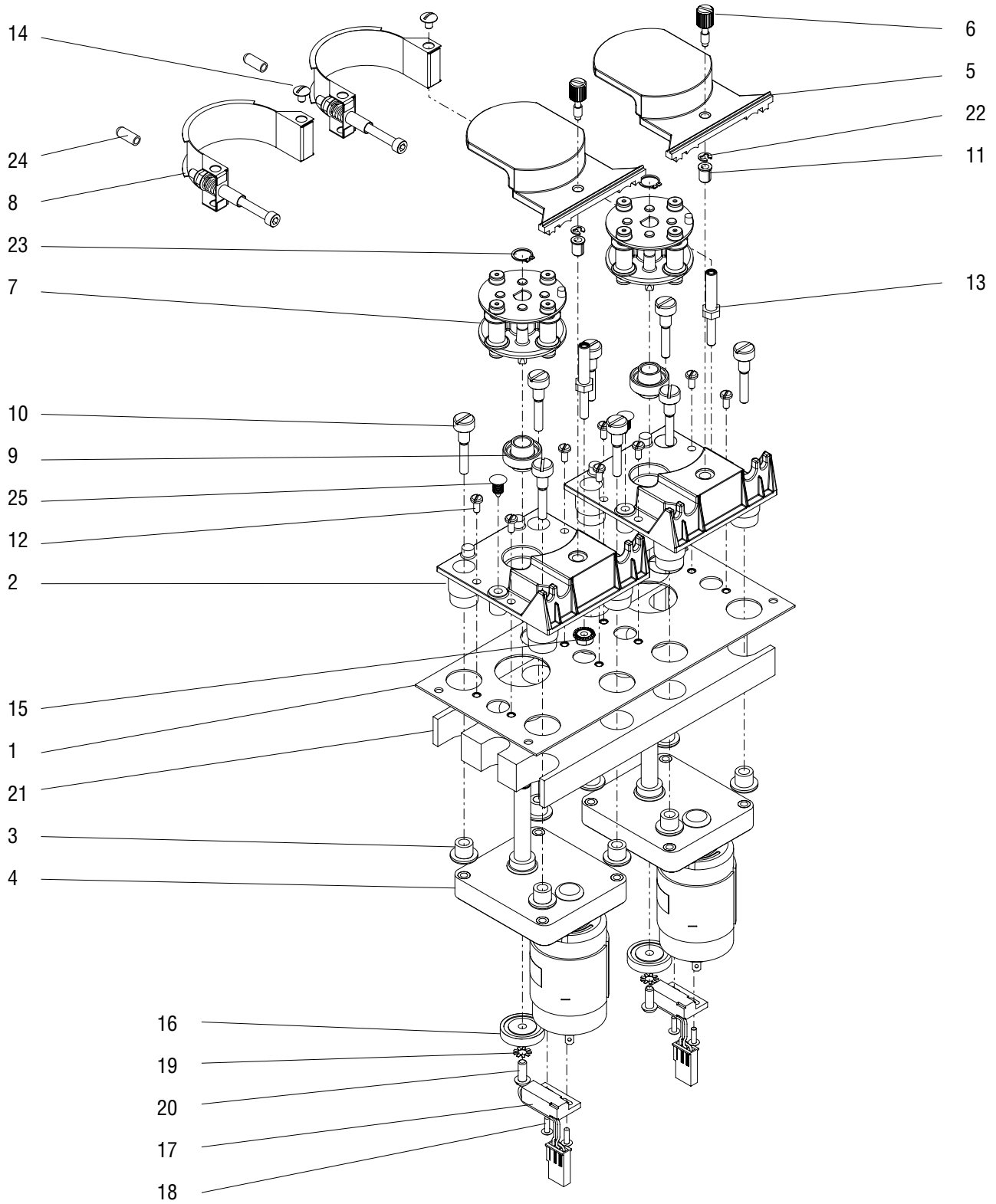

PUMP ASSEMBLY

ITEM	PART NO.	QTY.	DESCRIPTION
-	39286.1000	1	Pump Assy (Includes items 1 thru 25)
1	38683.0000	1	Bracket, Dual Pump
2	34166.0002	2	Block, Pump
3	32957.0000	8	Bushing
4	34536.0001	2	Motor, Gear 24VDC
5	34167.0000	2	Cover, Pump Block
6	34997.0001	2	Screw, Captive #10-32 X .625"
7	32706.1000	2	Rotor Assy
8	40037.1000	2	Compression Band Assy.
9	33825.0000	2	Bearing, Sleeve-Pump Assy
10	32927.0000	8	Screw, Shoulder #10-32 UNF
11	32928.0000	2	Insert, Threaded #10-32
12	02328.0003	8	Screw, Pan Head #6-32 x .312"
13	32609.0000	2	Standoff, Pump Band
14	01311.0001	2	Screw, Truss Head Locking #8-32 x .25"
15	34765.0000	2	Nut, Flanged #10-32
16	32654.0000	2	Magnet Hub
17	33608.1000	2	Sensor Assy, RPM
18	02336.0000	4	Screw, Truss Head #4-40 x .38"
19	01512.0000	2	Lockwasher, Ext - tooth #10
20	01331.0004	2	Screw, Round Head Locking #10-32 x .5"
21	39293.0000	1	Insulation, Pump
22	34998.0000	2	E-ring, Retaining
23	32652.0000	2	Retaining Ring
24	12919.0009	2	Cap
25	36149.0000	2	Fastener, Snap in

* Indicates the part number listed is for reference only. See DESCRIPTION for possible service replacement.

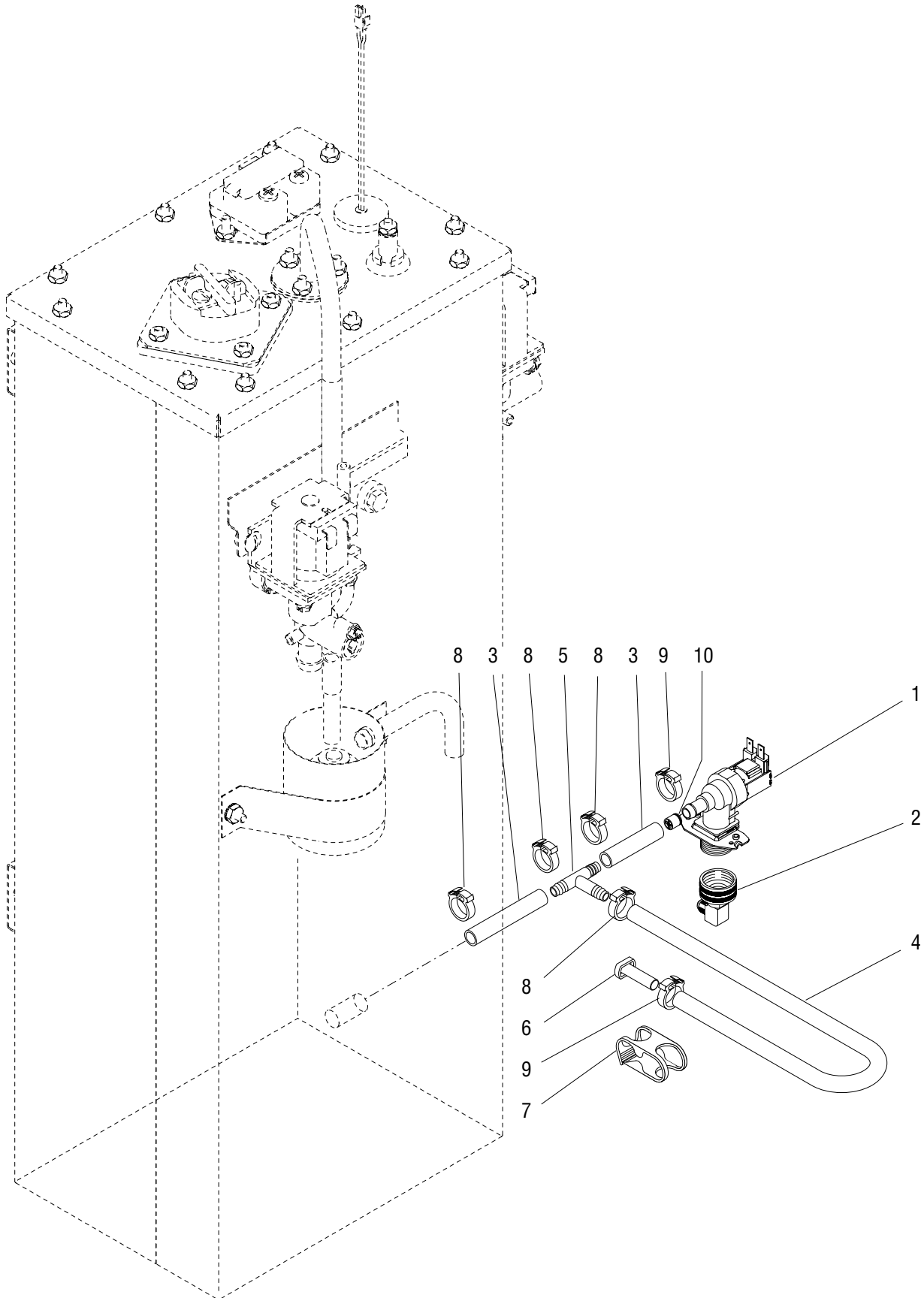

WATER INLET & TANK DRAIN

ITEM	PART NO.	QTY.	DESCRIPTION
1	40506.0004	1	Valve, Water Inlet
	32283.0000	2	Screw, Pan Head M4 x 6mm
2	37297.0006	1	Fitting, Elbow .75" x .25" Flare
3	20976.0014*	2	Tube, Silicone .38" ID x 3.25" (Order item 11)
4	20976.0000*	1	Tube, Silicone .38" ID x 30.0" (Order item 11)
5	38948.0000	1	Tee .50" Barb
6	34392.0000	1	Plug, Hose
7	11630.0001	1	Clamp, Shut Off
8	12422.0005	4	Clamp, Hose .62 - .71"
9	12422.0001	2	Clamp, Hose .59 - .66"
10	36378.0001	1	Valve, Check 2.5psi
11	20976.1000	-	Tube, Silicone .38" ID x 12.0" (Use as required)
	20976.1001	-	Tube, Silicone .38" ID x 36.0" (Use as required)
	20976.1002	-	Tube, Silicone .38" ID x 120.0" (Use as required)

* Indicates the part number listed is for reference only. See DESCRIPTION for possible service replacement.

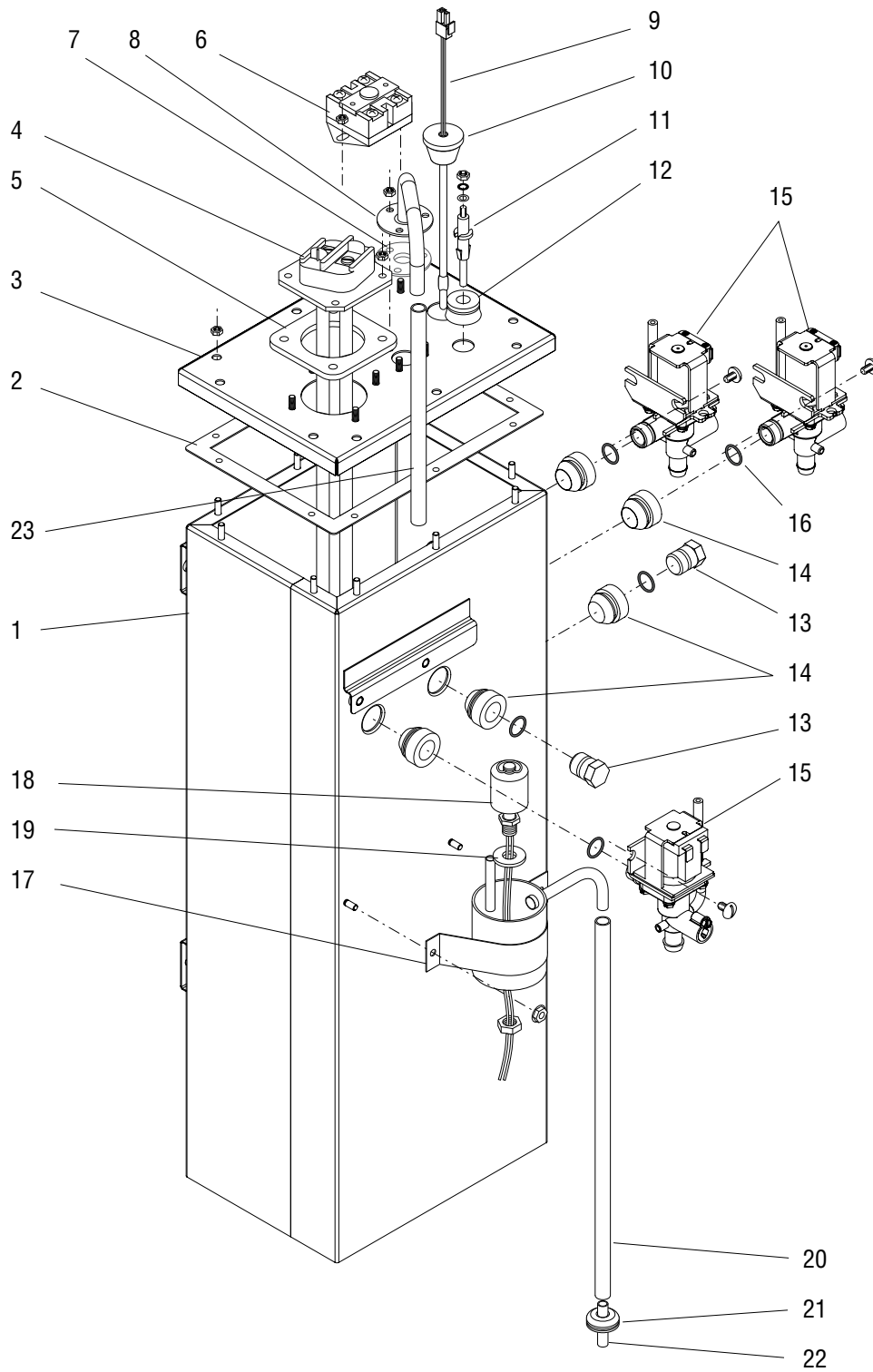

TANK ASSEMBLY

ITEM	PART NO.	QTY.	DESCRIPTION
1	37978.1002	1	Tank
	01317.0005	3	Screw, Truss Head Locking #8-32 x .38"
2	22978.0000	1	Gasket, Tank Lid
3	28281.0003	1	Lid, Tank
	00908.0000	10	Nut, Hex #8-32
4	36741.1000	1	Tank Heater 1700W (Includes item 5)
	00908.0000	4	Nut, Hex #8-32
5	12398.0002	1	Gasket, Tank Heater
6	23717.0003	1	Limit Thermostat
	00908.0000	2	Nut, Hex #8-32
7	05515.0000	1	Gasket, Overflow Tube
8	28292.0003	1	Tube, Overflow
	00908.0000	3	Nut, Hex #8-32
9	28891.1008	1	Probe, Temperature & Dry Plug
10	33801.0001	1	Grommet
11	20936.1000	1	Probe, Liquid Level (Includes hardware below)
	01501.0000	1	Washer
	20203.0100	1	Lockwasher, Internal-Tooth #8
	00908.0000	1	Nut, Hex #8-32
12	38114.0000	1	Grommet
13	26369.1000	2	Plug (Includes item 16)
14	37970.0000	5	Grommet
15	39285.1000	3	Valve Assy, Vented (Each includes item 16)
	01326.0000	3	Screw, Truss Head #10-32 x .25"
16	24733.0011	5	O-ring
17	12552.0003	1	Cup, Overflow
	00970.0000	2	Nut, Keps #8-32
18	03803.0002	1	Switch, Level (Includes item 19)
	00946.0000	1	Nut, Hex Brass
19	03633.0000	1	Gasket
20	28526.0002*	1	Tube, Silicone .38" ID x 16.0" (Order item 24)
21	02536.0000	1	Grommet
22	21801.0002	1	Tube SST
23	28526.0028*	1	Tube, Silicone .38" ID x 9.5" (Order item 24)
24	28526.1000	-	Tube, Silicone .38" ID x 12.0" (Use as required)
	28526.1001	-	Tube, Silicone .38" ID x 36.0" (Use as required)
	28526.1002	-	Tube, Silicone .38" ID x 60.0" (Use as required)
	28526.1003	-	Tube, Silicone .38" ID x 120.0" (Use as required)

* Indicates the part number listed is for reference only. See DESCRIPTION for possible service replacement.

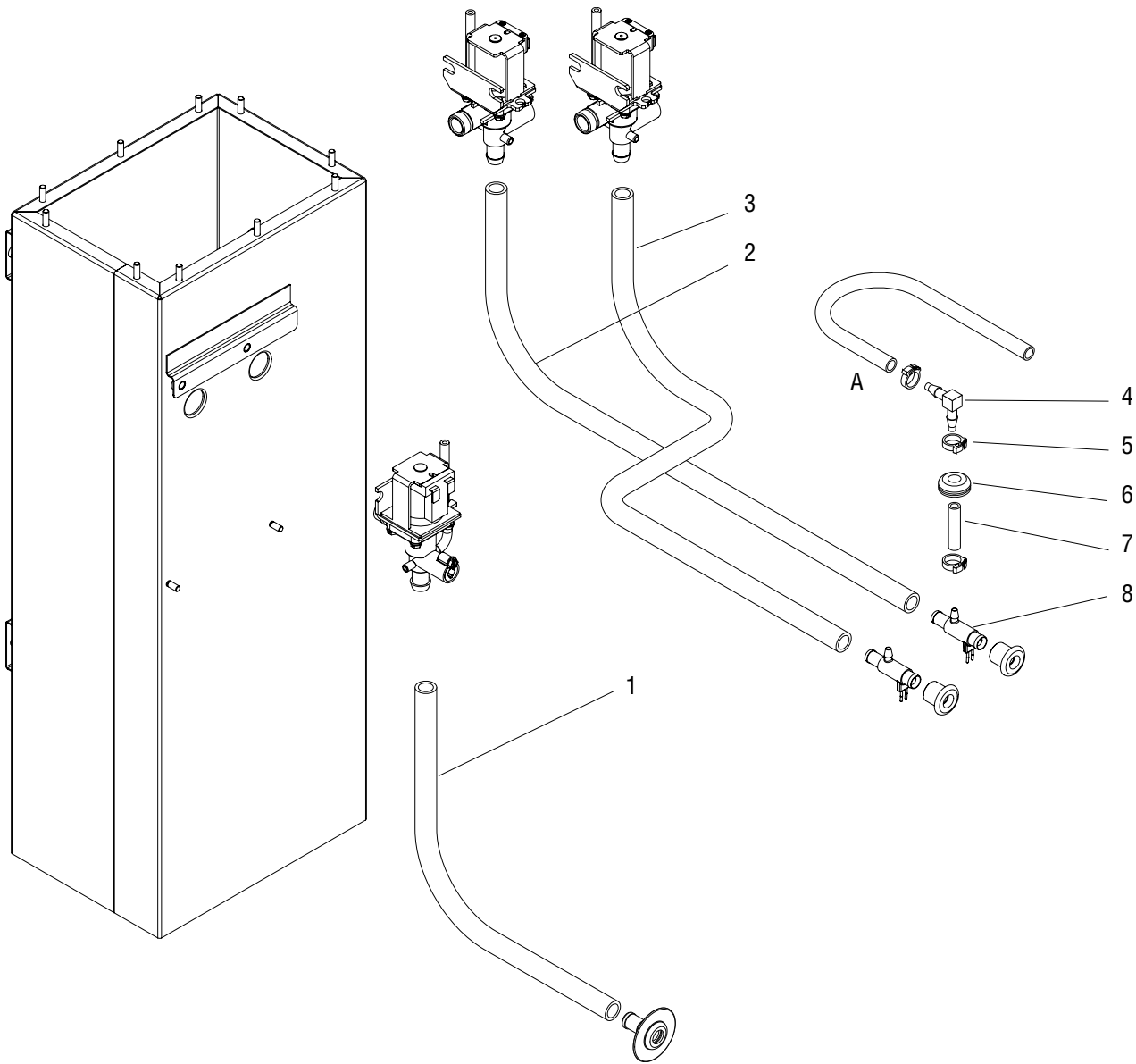

P4330.70

NOTE: Letters appearing within this illustration correspond to matching connections in other illustrations.

DISPENSE VALVES & LINES

ITEM	PART NO.	QTY.	DESCRIPTION
1	28526.0023*	1	Tube, Silicone .313" ID x 17.0" (Order item 9)
2	28526.0001*	1	Tube, Silicone .313" ID x 18.5" (Order item 9)
3	28526.0027*	1	Tube, Silicone .313" ID x 16.5" (Order item 9)
4	34714.0000	2	Elbow
5	12422.0003	4	Clamp, Hose .34 - .39"
6	02536.0000	2	Grommet
7	34729.0006*	2	Tube, Norprene .187" ID x 1.25" (Order item 10)
8	44249.0000	2	Manifold
9	28526.1000	-	Tube, Silicone .313" ID x 12.0" (Use as required)
	28526.1001	-	Tube, Silicone .313" ID x 36.0" (Use as required)
	28526.1002	-	Tube, Silicone .313" ID x 60.0" (Use as required)
	28526.1003	-	Tube, Silicone .313" ID x 120.0" (Use as required)
10	34729.1000	-	Tube, Norprene .187" ID x 8.9" (Use as required)

* Indicates the part number listed is for reference only. See DESCRIPTION for possible service replacement.

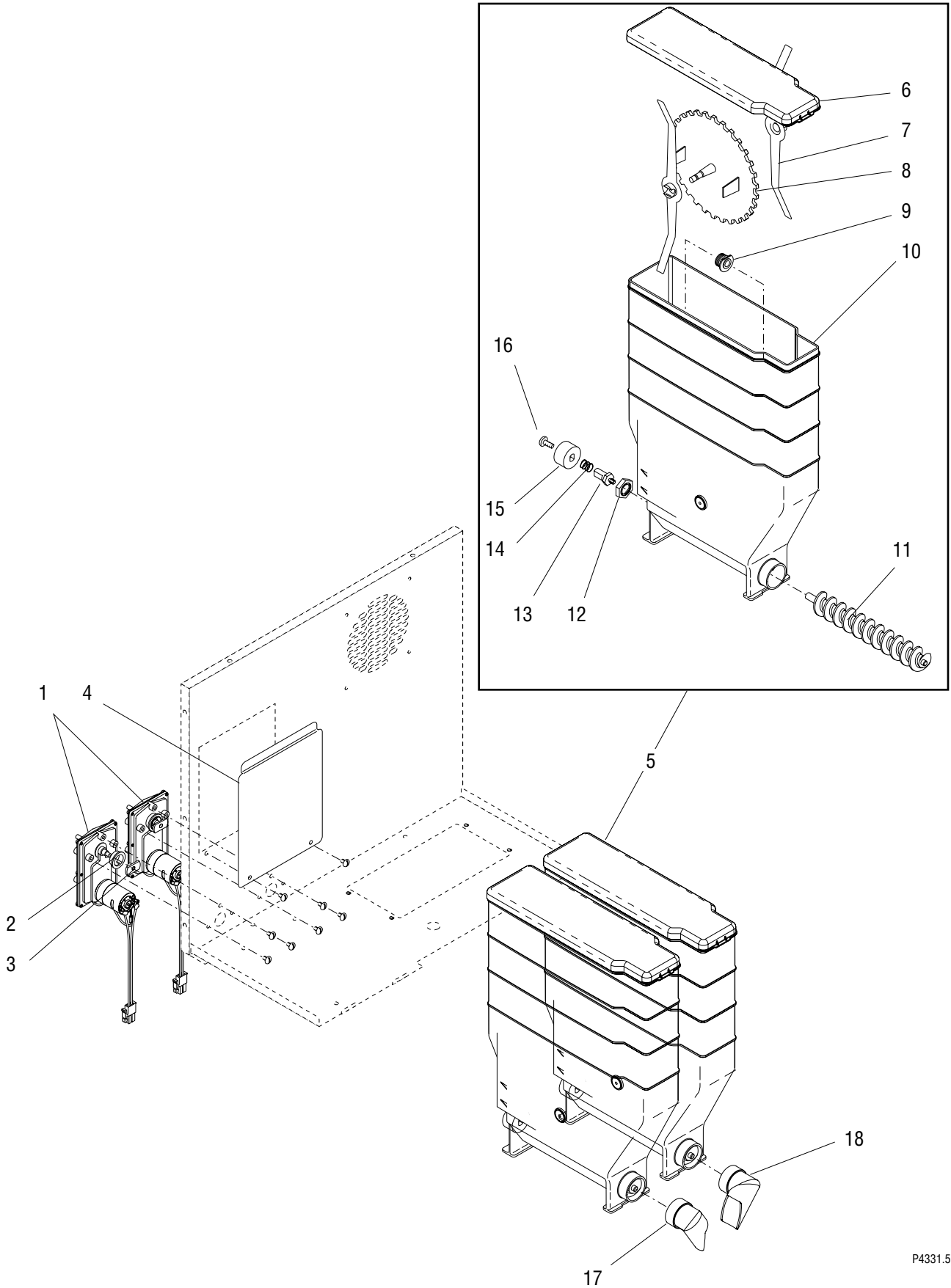

P4331.50

AUGER DRIVE & HOPPER ASSY.

ITEM	PART NO.	QTY.	DESCRIPTION
1	37037.0001	2	Gearmotor Assy (Includes items 2 & 3)
	01311.0000	6	Screw, Truss Head #8-32 x .25"
2	26401.0000	2	Dust Seal
3	36773.0000	2	Drive Plate
4	38701.0000	1	Panel, Inner Access
	01311.0000	2	Screw, Truss Head #8-32 x .25"
5	37010.1002	2	Hopper Assy (Each includes items 6 - 16)
6	36653.0001	1	Lid, Hopper
7	32337.0000	2	Mixing Blade
8	32386.0001	1	Disk, Agitator (30 Tooth)
9	28067.0000	1	Bushing, Auger Drive Shaft
10	37011.0001	1	Hopper
11	38330.0000	1	Auger
12	25743.0000	1	Locknut
13	37539.1000	1	Shaft, Hopper Drive (Includes item 16)
14	36774.0000	1	Spring
15	36770.0000	1	Coupling, Auger Drive
16	01326.0002	1	Screw, Truss Head Locking #10-32 x .312"
17	39263.0000	1	Elbow, Ejector Left
18	39263.0001	1	Elbow, Ejector Right

* Indicates the part number listed is for reference only. See DESCRIPTION for possible service replacement.

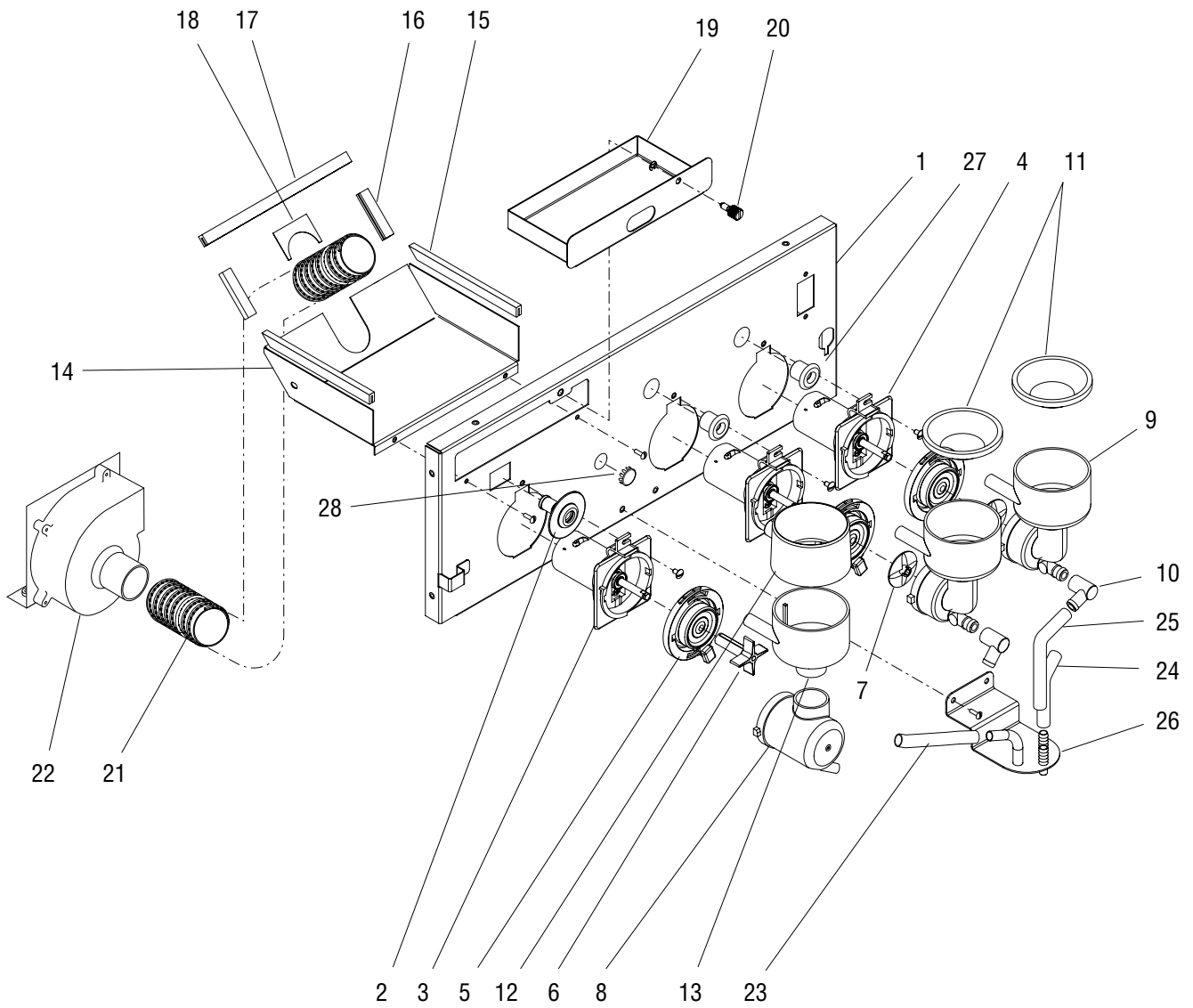

MIXING/WHIPPER CHAMBER & DRIVE MOTOR

ITEM	PART NO.	QTY.	DESCRIPTION
1	38089.0009	1	Panel, Whipper
	01311.0001	5	Screw, Truss Head Locking #8-32 x .25"
2	39315.0000	1	Fitting, Water Inlet
3	39309.0001	1	Motor, Whipper
	01308.0000	1	Screw, Truss Head #6-32 x .25"
4	39309.0000	2	Motor, Whipper
	01308.0000	2	Screw, Truss Head #6-32 x .25"
5	39313.1001	3	Base, Whipper Chamber (Includes O-ring & Shaft Seal)
6	42266.0000	1	Frother (Refer to item 31)
7	39314.0000	2	Impeller (Refer to item 31)
8	42647.0000	1	Whipper Chamber
9	39311.0000	2	Whipper Chamber
10	39312.0000	2	Fitting, Outlet
11	39552.0000	2	Trap, Condensation
12	39310.0000	1	Steam Collector
13	42281.0000	1	Mixing Bowl
14	38086.0002	1	Shelf
	02336.0000	2	Screw, Truss Head #4-40 x .38"
15	02434.0014*	2	Gasket, U-channel 4.85" (Order item 29)
16	02434.0017*	2	Gasket, U-channel 1.67" (Order item 29)
17	02434.0016*	1	Gasket, U-channel 6.50" (Order item 29)
18	38345.0000	1	Plate, Filler
19	38087.0003	1	Tray
20	37988.0000	1	Screw, Captive #10-32 x .50"
	34998.0000	1	E-ring
21	28297.0000	1	Hose, Vacuum
22	28295.0000	1	Fan, Blower
	01311.0001	2	Screw, Truss Head Locking #8-32 x .25"
23	11707.0054*	1	Tube, Silicone .25" ID x 3.25" (Order item 30)
24	11707.0046*	1	Tube, Silicone .25" ID x 2.5" (Order item 30)
25	11707.0047*	1	Tube, Silicone .25" ID x 6.5" (Order item 30)
26	38096.0003	1	Bracket, Beverage Outlet
	01311.0001	2	Screw, Truss Head Locking #8-32 x .25"

(Continued)

* Indicates the part number listed is for reference only. See DESCRIPTION for possible service replacement.

(Continued)

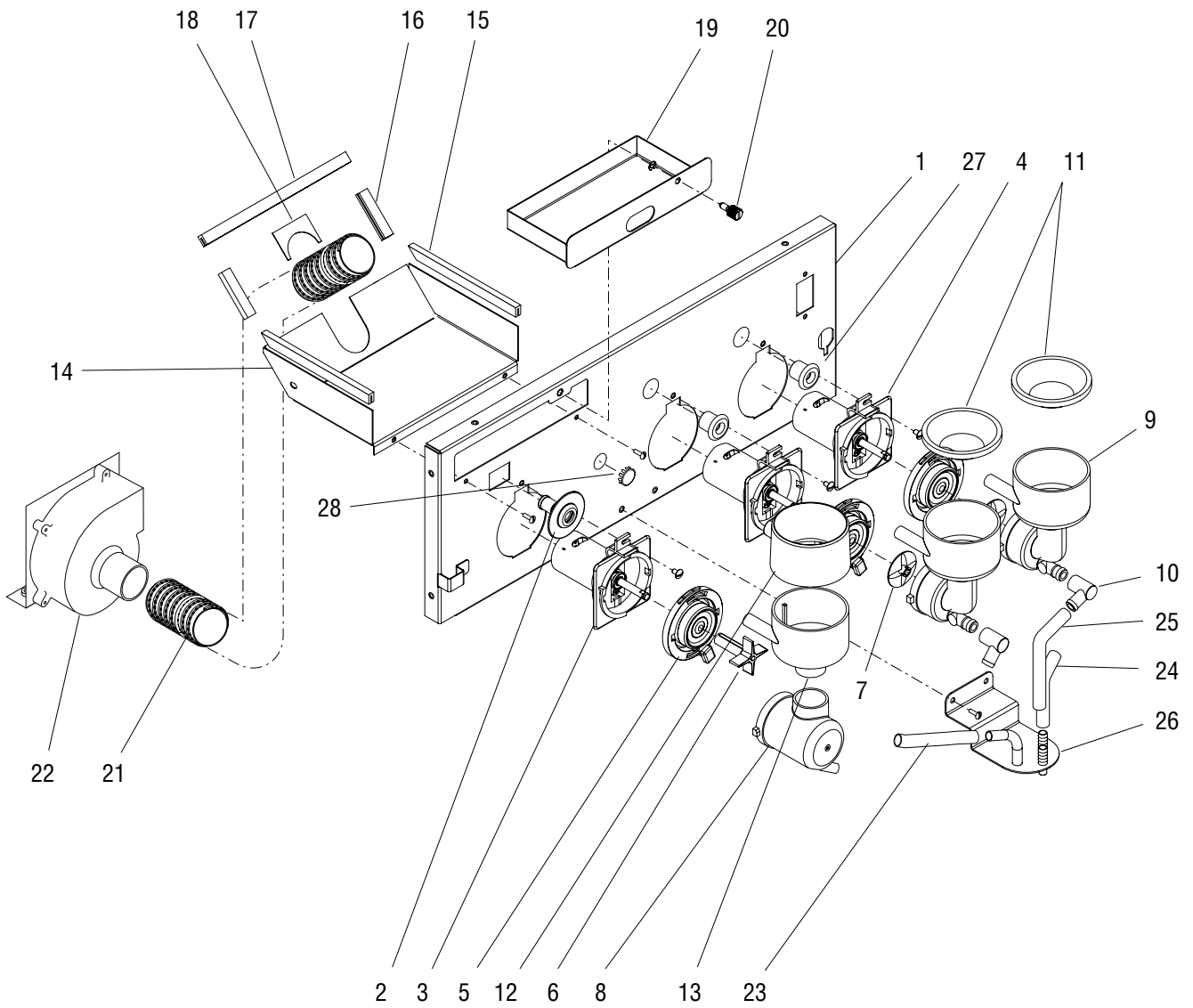

MIXING/WHIPPER CHAMBER & DRIVE MOTOR

ITEM	PART NO.	QTY.	DESCRIPTION
27	43620.0000	2	Grommet
28	00619.0009	1	Plug, Hole
29	02434.1000	-	Gasket, U-channel 18.0" (Use as required)
	02434.1001	-	Gasket, U-channel 36.0" (Use as required)
30	11707.1000	-	Tube, Silicone .25" ID x 12.0" (Use as required)
	11707.1001	-	Tube, Silicone .25" ID x 36.0" (Use as required)
	11707.1002	-	Tube, Silicone .25" ID x 120.0" (Use as required)
31	42934.0000	-	Tool, Frother Removal (Not Illustrated)

* Indicates the part number listed is for reference only. See DESCRIPTION for possible service replacement.

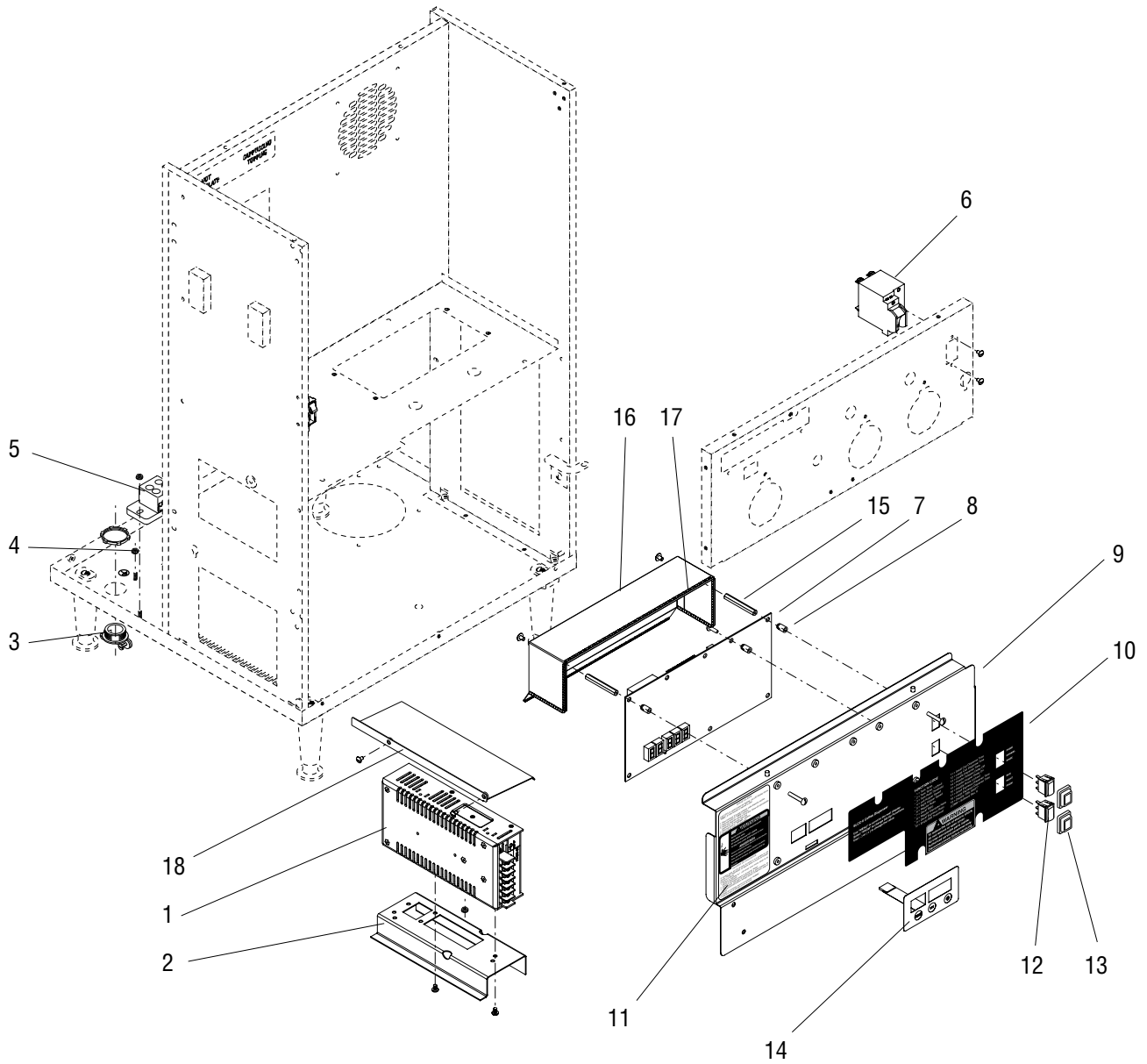

ELECTRICAL COMPONENTS

ITEM	PART NO.	QTY.	DESCRIPTION
1	33363.0001	1	Power Supply Module
	24003.0201	3	Screw, Pan Head M3 x 4mm
2	34345.0001	1	Bracket
	00970.0000	1	Nut, Keps #8-32
3	01590.0000	1	Cable Connector
4	00970.0000	1	Nut, Keps #8-32 (Grounding)
5	07038.0000	1	Terminal Block
	00970.0000	2	Nut, Keps #8-32
6	38894.0001	1	Switch
	01308.0000	2	Screw, Truss Head #6-32 x .25"
7	39044.1004	1	Circuit Board
	01390.0000	6	Screw, Round Head #8-32 x .625"
8	29081.0001	9	Spacer
9	36224.1001	1	Panel w/Decals, Lower Control (Includes items 10 & 11)
	01311.0001	2	Screw, Truss Head Locking #8-32 x .25" (Drip Tray Mounting)
	01311.0000	2	Screw, Truss Head #8-32 x .25"
10	39280.0002	1	Decal, Main Panel
11	39591.0000	1	Decal, Rinse Alarm
12	27437.0001	2	Switch
13	34390.0000	2	Cap, Rocker Switch
14	39141.0000	1	Membrane Switch
15	41851.0000	2	Stand-off, Hex #8-32
	01321.0000	2	Screw, Truss Head #8-32 x 1.0"
16	41853.1001	1	Cover (Includes item 17)
	01311.0000	2	Screw, Truss Head #8-32 x .25"
17	38278.1002	-	Edging 36"
18	42018.0000	1	Panel
	01311.0001	2	Screw, Truss Head #8-32 x .25"

The following items are not illustrated:

19	35260.0000	1	Cable Mount
20	39291.0007	1	Wiring Harness, Main
21	39292.0001	1	Wiring Harness, Door Interconnect
22	01666.0001	2	Bushing, Strain Relief (Door Harness)
23	39317.0000	1	Wiring Harness, Pumps
24	20630.0005	1	Power Cord

* Indicates the part number listed is for reference only. See DESCRIPTION for possible service replacement.

NUMERICAL INDEX

PART NO.	PAGE NO.	PART NO.	PAGE NO.	PART NO.	PAGE NO.	PART NO.	PAGE NO.
00619.0009	27	12552.0003	19	33825.0000	15	38114.0000	19
00656.0001	5	12919.0009	15	34166.0002	15	38278.1002	29
00824.0002	5	20203.0100	19	34167.0000	15	38330.0000	23
00908.0000	19	20630.0005	29	34345.0001	29	38345.0000	25
00946.0000	19	20936.1000	19	34362.0000	9	38664.1003	5
00970.0000	13,19,29	20960.0000	5	34390.0000	29	38683.0000	15
00986.0000	5	20976.0000	17	34392.0000	17	38701.0000	23
00991.0002	5	20976.0014	17	34472.1001	9	38808.0000	13
01308.0000	25,29	20976.1000	17	34536.0001	15	38811.0000	13
01311.0000	5,23,29	20976.1001	17	34666.0000	5	38894.0001	29
01311.0001	5,9,11,15,25,29	20976.1002	17	34667.0000	9	38933.0000	9
01311.0003	5,7	21801.0002	19	34714.0000	11,21	38948.0000	17
01311.0005	9	22978.0000	19	34729.0003	11	38990.1001	5
01315.0000	13	23717.0003	19	34729.0006	21	39030.0000	9
01317.0005	19	24003.0201	29	34729.1000	21	39033.0000	9
01321.0000	29	24224.0000	9	34765.0000	15	39034.0000	9
01326.0000	19	24457.0002	9	34997.0001	15	39036.0000	9
01326.0002	23	24733.0011	19	34998.0000	15,25	39038.0000	9
01331.0004	15	25743.0000	23	35052.1002	9	39040.1000	9
01347.0000	9	26008.0001	5	35057.0000	11	39041.1004	9
01382.0002	7	26369.1000	19	35260.0000	9,29	39044.1004	29
01384.0002	13	26401.0000	23	35912.1001	5	39141.0000	29
01390.0000	29	26528.0000	5	35912.1004	5	39167.0003	9
01403.0000	9	27437.0001	29	35915.1002	7	39258.0007	9
01501.0000	19	28067.0000	23	35916.1002	5	39263.0000	23
01509.0001	5	28095.0000	9	35926.0000	5	39263.0001	23
01512.0000	15	28281.0003	19	36149.0000	15	39280.0002	29
01526.0001	5	28292.0003	19	36224.1001	29	39284.0000	5
01590.0000	29	28295.0000	25	36378.0001	17	39285.1000	19
01666.0001	29	28297.0000	25	36647.0001	5,9	39286.1000	15
02328.0003	15	28526.0001	21	36653.0001	23	39291.0007	29
02336.0000	5,15	28526.0002	19	36670.0000	7	39292.0001	29
02336.0000	25	28526.0023	21	36741.1000	19	39293.0000	15
02434.0014	25	28526.0027	21	36770.0000	23	39308.0000	7
02434.0016	25	28526.0028	19	36773.0000	23	39309.0000	25
02434.0017	25	28526.1000	19,21	36774.0000	23	39309.0001	25
02434.1000	27	28526.1001	19,21	36896.0000	5	39310.0000	25
02434.1001	27	28526.1002	19,21	37010.1002	23	39311.0000	25
02536.0000	19,21	28526.1003	19,21	37011.0001	23	39312.0000	25
03633.0000	19	28891.1008	19	37037.0001	23	39313.1001	25
03803.0002	19	29081.0001	29	37065.0001	7	39314.0000	25
03996.0000	5	32283.0000	17	37297.0006	17	39315.0000	25
05515.0000	19	32337.0000	23	37500.0206	11	39317.0000	29
07038.0000	29	32386.0001	23	37539.1000	23	39318.0008	5
11630.0001	17	32609.0000	15	37881.0000	5	39474.0000	9
11646.0002	9	32652.0000	15	37970.0000	19	39479.0000	9
11707.0046	25	32654.0000	15	37978.1002	19	39552.0000	25
11707.0047	25	32706.1000	15	37988.0000	25	39583.0000	5
11707.0054	25	32734.0000	13	38077.1006	5	39591.0000	29
11707.1000	27	32927.0000	15	38080.0001	5	40037.1000	15
11707.1001	27	32928.0000	15	38082.0000	5	40506.0004	17
11707.1002	27	32957.0000	15	38084.0003	5	41415.0000	13
12398.0002	19	33297.0002	13	38086.0002	25	41851.0000	29
12422.0001	17	33363.0001	29	38087.0003	25	41853.1001	29
12422.0003	11,21	33608.1000	15	38089.0009	25	42018.0000	29
12422.0005	17	33801.0001	19	38096.0003	25	42266.0000	25

NUMERICAL INDEX

PART NO.	PAGE NO.	PART NO.	PAGE NO.	PART NO.	PAGE NO.	PART NO.	PAGE NO.
42281.0000.....	25						
42647.0000.....	25						
42934.0000.....	27						
43620.0000.....	27						
44249.0000.....	21						
44646.0001.....	9						
45389.0000.....	5						
45391.0000.....	11						