BUNN®

***G9WD RH
for use with
Smart Funnel®***



ILLUSTRATED PARTS CATALOG

Designs, materials, weights, specifications, and dimensions for equipment or replacement parts are subject to change without notice.

BUNN-O-MATIC CORPORATION

POST OFFICE BOX 3227

SPRINGFIELD, ILLINOIS 62708-3227

PHONE: (217) 529-6601 FAX: (217) 529-6644



BUNN-O-MATIC COMMERCIAL PRODUCT WARRANTY

Bunn-O-Matic Corp. ("BUNN") warrants equipment manufactured by it as follows:

- 1) Airpots, thermal carafes, decanters, GPR servers, iced tea/coffee dispensers, MCP/MCA pod brewers thermal servers and Thermofresh servers (mechanical and digital)- 1 year parts and 1 year labor.
- 2) All other equipment - 2 years parts and 1 year labor plus added warranties as specified below:
 - a) Electronic circuit and/or control boards - parts and labor for 3 years.
 - b) Compressors on refrigeration equipment - 5 years parts and 1 year labor.
 - c) Grinding burrs on coffee grinding equipment to grind coffee to meet original factory screen sieve analysis - parts and labor for 4 years or 40,000 pounds of coffee, whichever comes first.

These warranty periods run from the date of installation BUNN warrants that the equipment manufactured by it will be commercially free of defects in material and workmanship existing at the time of manufacture and appearing within the applicable warranty period. This warranty does not apply to any equipment, component or part that was not manufactured by BUNN or that, in BUNN's judgment, has been affected by misuse, neglect, alteration, improper installation or operation, improper maintenance or repair, non periodic cleaning and descaling, equipment failures related to poor water quality, damage or casualty. In addition, the warranty does not apply to replacement of items subject to normal use including but not limited to user replaceable parts such as seals and gaskets. This warranty is conditioned on the Buyer 1) giving BUNN prompt notice of any claim to be made under this warranty by telephone at (217) 529-6601 or by writing to Post Office Box 3227, Springfield, Illinois 62708-3227; 2) if requested by BUNN, shipping the defective equipment prepaid to an authorized BUNN service location; and 3) receiving prior authorization from BUNN that the defective equipment is under warranty.

THE FOREGOING WARRANTY IS EXCLUSIVE AND IS IN LIEU OF ANY OTHER WARRANTY, WRITTEN OR ORAL, EXPRESS OR IMPLIED, INCLUDING, BUT NOT LIMITED TO, ANY IMPLIED WARRANTY OF EITHER MERCHANTABILITY OR FITNESS FOR A PARTICULAR PURPOSE. The agents, dealers or employees of BUNN are not authorized to make modifications to this warranty or to make additional warranties that are binding on BUNN. Accordingly, statements by such individuals, whether oral or written, do not constitute warranties and should not be relied upon.

If BUNN determines in its sole discretion that the equipment does not conform to the warranty, BUNN, at its exclusive option while the equipment is under warranty, shall either 1) provide at no charge replacement parts and/or labor (during the applicable parts and labor warranty periods specified above) to repair the defective components, provided that this repair is done by a BUNN Authorized Service Representative; or 2) shall replace the equipment or refund the purchase price for the equipment.

THE BUYER'S REMEDY AGAINST BUNN FOR THE BREACH OF ANY OBLIGATION ARISING OUT OF THE SALE OF THIS EQUIPMENT, WHETHER DERIVED FROM WARRANTY OR OTHERWISE, SHALL BE LIMITED, AT BUNN'S SOLE OPTION AS SPECIFIED HEREIN, TO REPAIR, REPLACEMENT OR REFUND.

In no event shall BUNN be liable for any other damage or loss, including, but not limited to, lost profits, lost sales, loss of use of equipment, claims of Buyer's customers, cost of capital, cost of down time, cost of substitute equipment, facilities or services, or any other special, incidental or consequential damages.

392, A Partner You Can Count On, AutoPOD, AXIOM, BrewLOGIC, BrewMETER, Brew Better Not Bitter, BrewWISE, BrewWIZARD, BUNN Espresso, BUNN Family Gourmet, BUNN Gourmet, BUNN Pour-O-Matic, BUNN, BUNN with the stylized red line, BUNNlink, Bunn-OMatic, Bunn-O-Matic, BUNNserve, BUNNSERVE with the stylized wrench design, Cool Froth, DBC, Dr. Brew stylized Dr. design, Dual, Easy Pour, EasyClear, EasyGard, FlavorGard, Gourmet Ice, Gourmet Juice, High Intensity, iMIX, Infusion Series, Intellisteam, My Café, Phase Brew, PowerLogic, Quality Beverage Equipment Worldwide, Respect Earth, Respect Earth with the stylized leaf and coffee cherry design, Safety-Fresh, savemycoffee.com, Scale-Pro, Silver Series, Single, Smart Funnel, Smart Hopper, SmartWAVE, Soft Heat, SplashGard, The Mark of Quality in Beverage Equipment Worldwide, ThermoFresh, Titan, trifacta, Velocity Brew, Air Brew, Air Infusion, Beverage Bar Creator, Beverage Profit Calculator, Brew better, not bitter., BUNNSource, Coffee At Its Best, Cyclonic Heating System, Daypart, Digital Brewer Control, Element, Nothing Brews Like a BUNN, Pouring Profits, Signature Series, Tea At Its Best, The Horizontal Red Line, Ultra are either trademarks or registered trademarks of Bunn-O-Matic Corporation. The commercial trifacta® brewer housing configuration is a trademark of Bunn-O-Matic Corporation.

TABLE OF CONTENTS

Electrical Controls	12
Hopper, Lid and Slide Assy	6
Housing, Base and Panels.....	4
Load Cell Assy	10
Motor, Burr Housing and Mounting Plate.....	8
Numerical Index.....	14

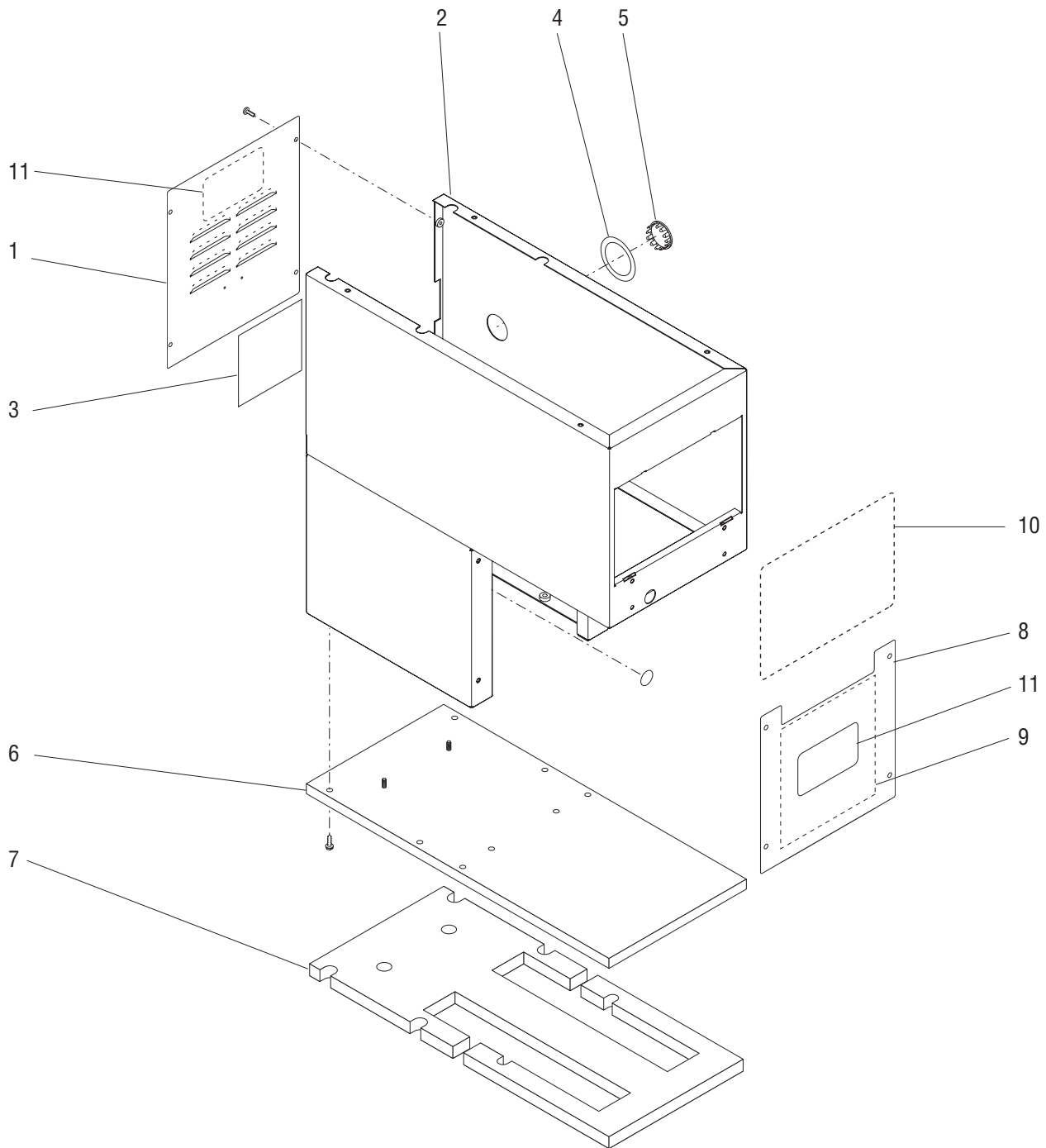

HOUSING, BASE AND PANELS

ITEM	PART NO.	QTY.	DESCRIPTION
1	41216.1000	1	Rear Panel w/Decals, SST (Includes item 11)
	41216.1001	1	Rear Panel w/Decals, BLK (Includes item 11)
	01311.0000	4	Screw, Truss Head, Locking #8-32 x .25"
	01311.0003	4	Screw, Truss Head, BLK, Locking #8-32 x .25"
2	41269.1000	1	Housing Assy w/Decals, SST (Includes items 3 & 4)
	41269.1001	1	Housing Assy w/Decals, BLK (Includes items 3 & 4)
3	20545.0000	1	Decal, Warning Electrical
4	05884.0000	1	Decal, Motor Reset
5	02999.0000	1	Plug, Hole SST 1.19" Dia.
	25126.0000	1	Plug, Hole BLK 1.19" Dia.
6	05752.0003*	1	Base SST
	05752.0004*	1	Base BLK
	02311.0000	6	Screw, Hex Washerhead #10-32 x .50"
7	05816.0002	1	Pad, Base
8	39072.1002	1	Panel Assy W/Decals, SST (Includes item 9 & 11)
	39072.1001	1	Panel Assy W/Decals, BLK (Includes item 9 & 11)
	01311.0000	4	Screw, Truss Head, Locking #8-32 x .25"
	01311.0003	4	Screw, Truss Head, BLK, Locking #8-32 x .25"
9	41449.0000	1	Schematic 120V
10	-----	1	Membrane Switch (See ELECTRICAL CONTROLS)
11	37881.0000	2	Decal, No Serviceable Parts

* Indicates the part number listed is for reference only. See DESCRIPTION for possible service replacement.

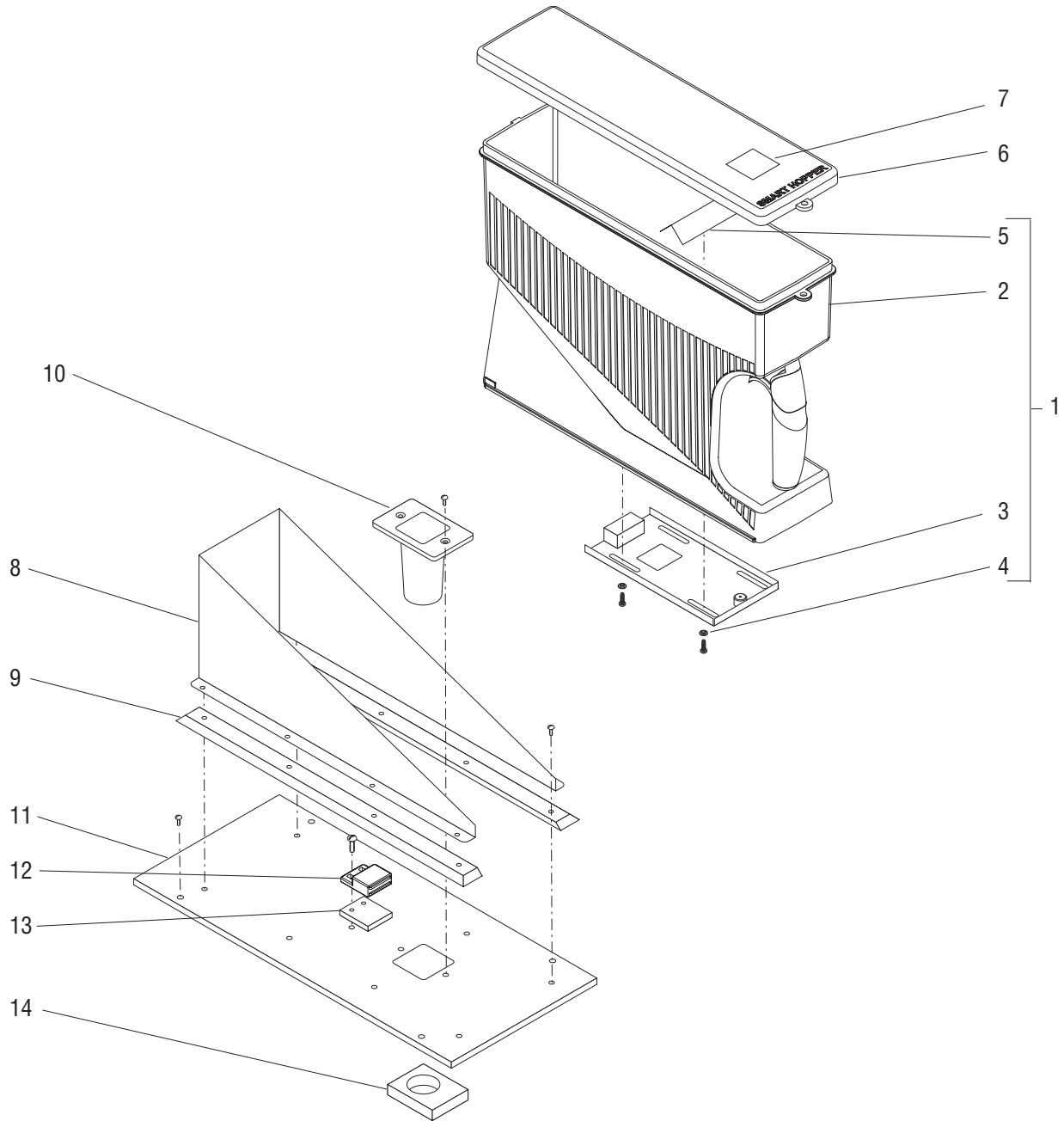

HOPPER, LID & SLIDE ASSEMBLY

ITEM	PART NO.	QTY.	DESCRIPTION
1	36845.0000	1	Hopper Assy (Includes items 2-7)
2	35732.0000*	1	Hopper (Order item 1)
3	35817.0000	1	Hopper Gate
	01383.0000	4	Screw, Pan Head #6-32 x .50"
4	35818.0000	4	Bushing
5	36711.0000	1	Baffle
6	35771.1000	1	Lid w/Decals (Includes item 7)
7	05876.0000	1	Decal, Caution
8	41226.0000	1	Hopper Wrapper, SST
	41226.0003	1	Hopper Wrapper, BLK
	01317.0004	8	Screw, Truss Head, SST, Locking #8-32 x .62"
	01317.0006	8	Screw, Truss Head, BLK, Locking #8-32 x .62"
9	41242.0000	2	Slide Rail
10	41223.0000	1	Chute
	01359.0000	2	Screw, Flat Head #8-32 x .38"
11	41212.0004	1	Cover SST
	41212.0003	1	Cover BLK
	01311.0001	4	Screw, Truss Head, SST, Locking #8-32 x .25"
	01311.0004	4	Screw, Truss Head, BLK, Locking #8-32 x .25"
12	35874.0001	1	Magnet Latch
	01317.0004	2	Screw, Truss Head, Locking #8-32 x .62"
13	41222.0000	1	Spacer
14	21457.0001	1	Gasket

* Indicates the part number listed is for reference only. See DESCRIPTION for possible service replacement.

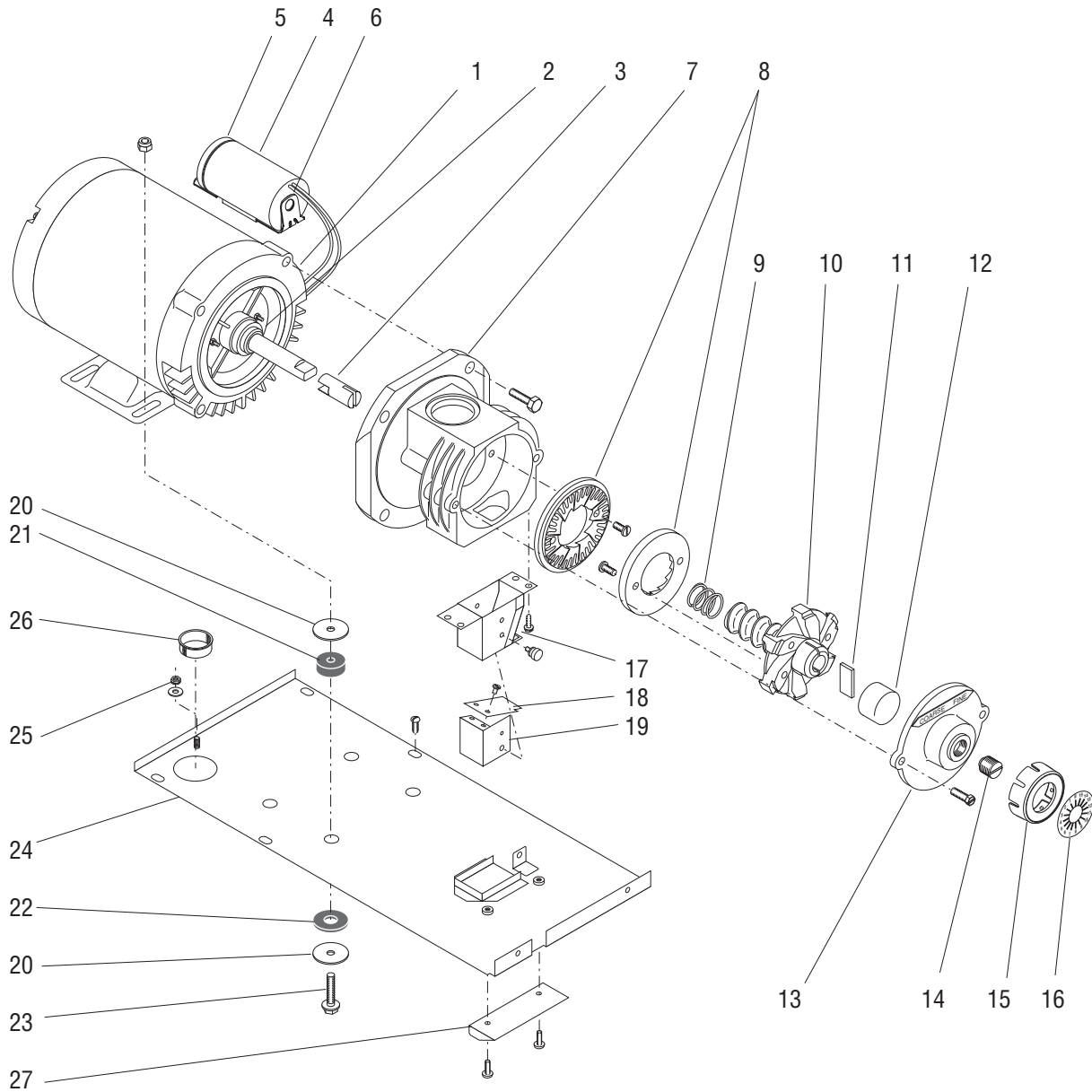

MOTOR, BURR HOUSING AND MOUNTING PLATE

ITEM	PART NO.	QTY.	DESCRIPTION
1	11029.1005	1	Motor Assy 120V (Includes item 2-6)
	11029.1006	1	Motor Assy 230V (Includes item 2-6)
2	05870.0000	1	Bushing, Bronze
3	11191.0001	1	Shaft Extension
4	35249.0000	1	Capacitor
5	35906.0000	1	Cap
6	35233.0000	1	Bracket
	37204.0000	2	Screw, Flat Head #10-32 x .375"
7	11180.0000	1	Burr Housing
	02313.0000	4	Screw, Hex Head .38"-16 x 1.0"
8	05861.1002	1	Burr Set (Includes 2 Burrs and Screws below)
	02314.0000	4	Screw, Pan Head .25"-20 x .50"
9	11192.0000	1	Spring
10	11185.0001	1	Burr Auger Rotor/Spring Assy (Includes item 9)
11	05852.0001	1	Shear Plate
12	00622.0000	1	Cup, Burr Rotor
13	05867.0000	1	Cap, Burr Housing
	20631.0000	2	Screw, Slotted Hex Head .25"-20 x .75"
14	35184.0000	1	Adjusting Screw
15	34107.0000	1	Cap, Indicator Adjustment
16	34213.0000	1	Decal, Burr Adjustment
17	05951.0000	1	Chute
	02330.0001	4	Screw, Slotted Hex Head #10-24 x .375"
18	05995.0000	1	Dechaffer Plate
	02327.0002	2	Screw, Pan Head #4-40 x .312"
19	05954.0000	1	Dechaffer Assy (Includes item 18)
	41480.0000	1	Thumbscrew
	01518.0000	1	Washer
20	01539.0000	8	Washer, Flat
21	05881.0000	4	Bushing
22	05882.0000	4	Washer 1.50" Dia.
23	42652.0000	4	Screw, Hex Head .312"-18 x 1.50"
	00987.0000	4	Nut, Lock .312"-18
24	29883.0004	1	Plate, Motor Mounting
	02311.0000	4	Screw, Hex Washerhead #10-32 x .50"
25	00971.0000	1	Grounding Nut, Keps #10-32
	01522.0000	1	Washer
26	01593.0000	1	Bushing 1.50" Dia. Hole
27	42991.0000	1	Guide, Funnel
	01317.0001	2	Screw, Truss Head, Locking #8-32 x .50"

* Indicates the part number listed is for reference only. See DESCRIPTION for possible service replacement.

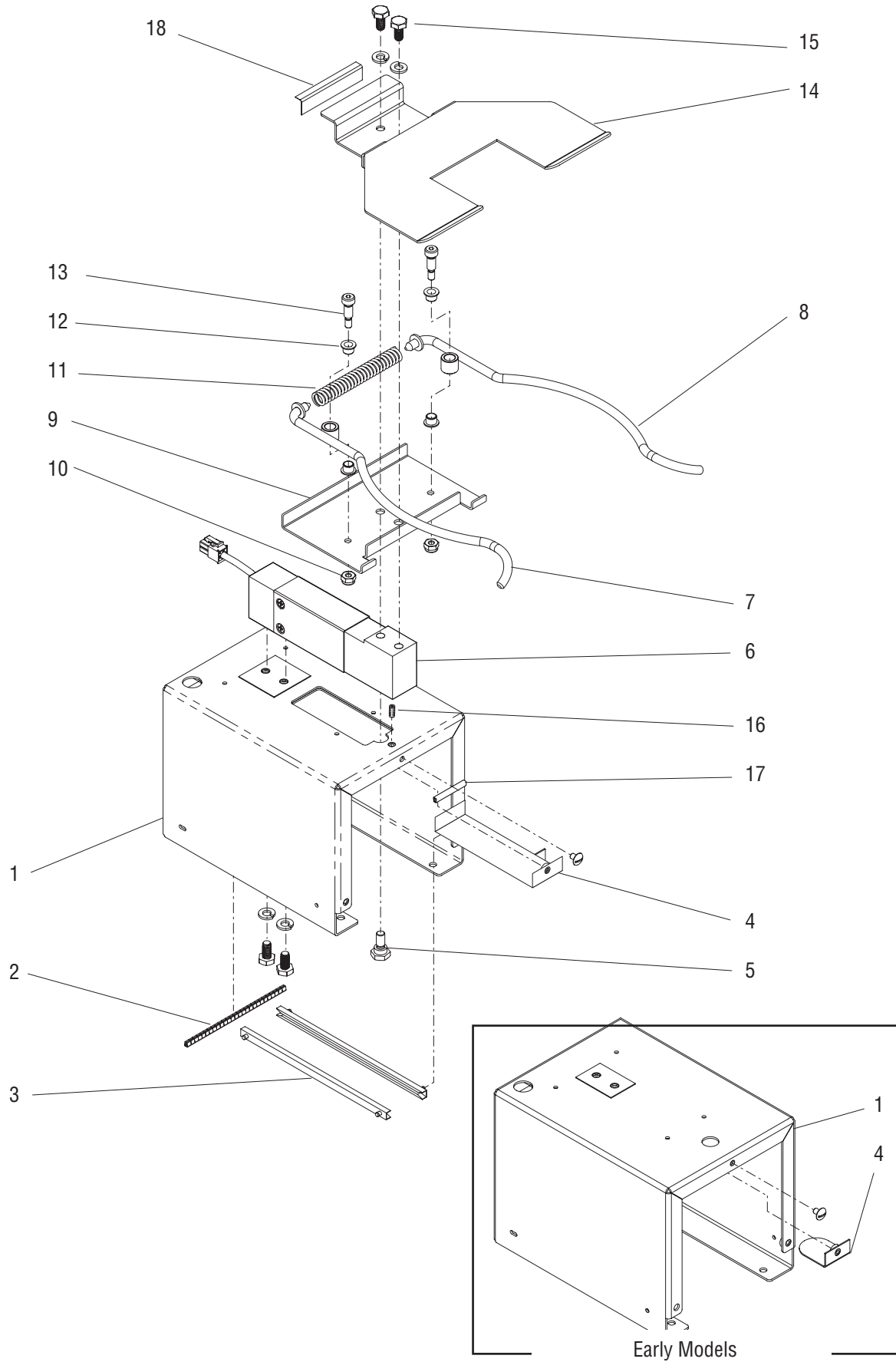

LOAD CELL ASSEMBLY

ITEM	PART NO.	QTY.	DESCRIPTION
1	41276.0001	1	Bracket (Early Models)
	41276.0002	1	Bracket (Late Models)
	01330.0000	2	Screw, Hex Washer #10-32 x .38"
	00970.0000	2	Nut, Keps #10-32
2	38278.0010*	1	Edging 4.05" (Order item 19)
3	26008.0001	2	Mount, Snap In
4	41770.0000	1	Bracket, Overload Shield (Early Models)
	43665.0000	1	Bracket, Overload Shield (Late Models)
	01311.0001	1	Screw, Truss Head, Locking #8-32 x .25"
5	39191.0000*	1	Shoulder Bolt, Transducer
6	41353.1001	1	Transducer Assy (Includes items 5 & 15)
7	39075.1001	1	Funnel Rail Assy, Left (Includes items 10 & 13)
8	39075.1000	1	Funnel Rail Assy, Right (Includes items 10 & 13)
9	47373.0000	1	Support Assy
10	00991.0005	2	Nut, Elastic Lock #10-24
11	41350.0000	1	Spring
12	41351.0000	4	Bearing
13	25692.0001	2	Shoulder Screw
14	39228.0003*	1	Funnel Guide
15	37549.0001	4	Screw, Hex Head, Locking .25-20 x .50"
	01538.0000	4	Lockwasher, Split .25"
16	43663.0000	1	Setscrew
17	38278.0016*	1	Edging 1.25" (Order item 19)
18	M2547.0000*	-	Tape, Pressure Sensitive
19	38278.1002	-	Edging 36.0" (Use as required)

* Indicates the part number listed is for reference only. See DESCRIPTION for possible service replacement.

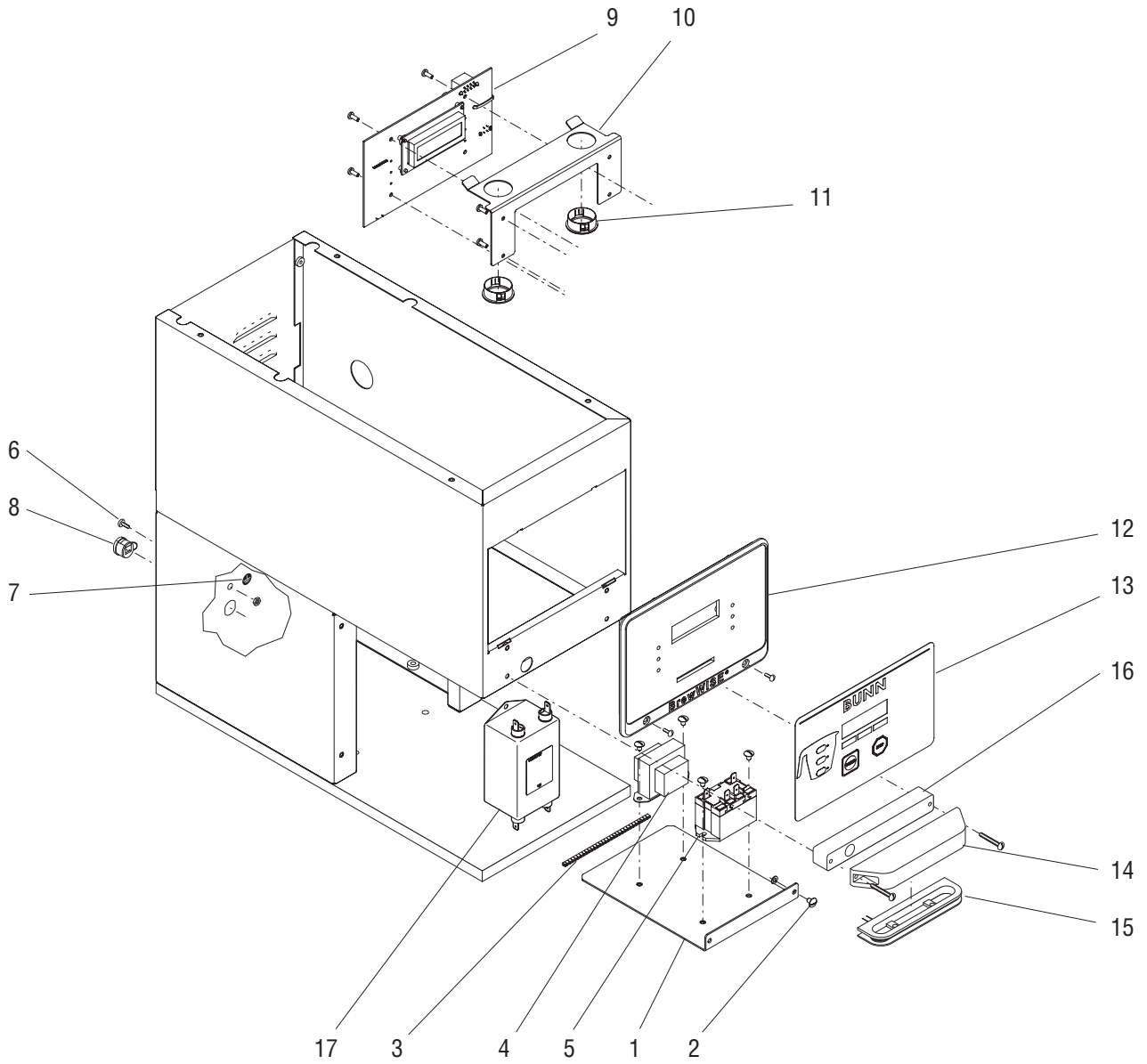

ELECTRICAL CONTROLS

ITEM	PART NO.	QTY.	DESCRIPTION
1	41279.0000	1	Bracket
2	01311.0000	1	Screw, Truss Head #8-32 x .25"
	01516.0000	1	Washer, Screw Retaining #8
3	38278.0011*	1	Edging 4.60" (Order item 24)
4	34307.1001	1	Transformer 120V
	34307.1002	1	Transformer 230V
	01311.0001	2	Screw, Truss Head, Locking #8-32 x .25"
5	37711.0003	1	Relay 120V
	01311.0001	2	Screw, Truss Head, Locking #8-32 x .25"
6	01327.0000	1	Screw, Ground Pan Head SST #10-32 x .38"
	00991.0003	1	Nut, Elastic Lock #10-32
7	00824.0002	1	Decal, Ground Screw
8	01686.0000	1	Bushing, Strain Relief 120V
9	41768.1012	1	Circuit Board, Grinder 120V
	01383.0001	4	Screw, Pan Head #6-32 x .38"
10	41297.0000	1	Bracket
	01383.0001	2	Screw, Pan Head #6-32 x .38"
11	00718.0000	2	Bushing, Snap In
12	35770.0000	1	Bezel
	01347.0002	2	Screw, Truss Head Blk #6-32 x .38"
13	35574.1004	1	Membrane Switch Assy (Includes item 12)
14	33303.0000	1	Cover, Sensing Coil
	02370.0001	2	Screw, Pan Head #6-32 x 1.25"
15	33302.0000	1	Sensing Coil, Grinder
16	47455.0000	1	Spacer
17	36801.0001	1	EMI Filter 230V
	01347.0000	2	Screw
	00991.0002	2	Nut

Note: The following items are not illustrated

18	41384.0000	1	Wiring Harness, Main
19	36372.0001	1	Wiring Harness, Read/Write Coil
20	40701.0012	1	Cord Assy, Power 120V
	28111.0010	1	Cord Assy, Power 230V
21	45723.0000	1	Wiring Harness, EMI Filter 230V
22	35260.0000	1	Cable Mount
23	36329.0000*	1	Tie, Cable 4.0"
24	38278.1002	-	Edging 36.0" (Use as required)

* Indicates the part number listed is for reference only. See DESCRIPTION for possible service replacement.

NUMERICAL INDEX

PART NO.	PAGE NO.	PART NO.	PAGE NO.	PART NO.	PAGE NO.	PART NO.	PAGE NO.
00622.0000	9	20545.0000	5	41269.1000	5		
00718.0000	13	20631.0000	9	41269.1001	5		
00824.0002	13	21457.0001	7	41276.0001	11		
00970.0000	11	25126.0000	5	41276.0002	11		
00971.0000	9	25692.0001	11	41279.0000	13		
00991.0002	13	26008.0001	11	41297.0000	13		
00991.0003	13	28111.0010	13	41350.0000	11		
00987.0000	9	29883.0004	9	41351.0000	11		
00991.0005	11	33302.0000	13	41353.1001	11		
01311.0000	5,13	33303.0000	13	41384.0000	13		
01311.0003	5	34107.0000	9	41449.0000	5		
01311.0001	7,9,11,13	34213.0000	9	41480.0000	9		
01311.0004	7	34307.1001	13	41768.1012	13		
01317.0004	7	34307.1002	13	41770.0000	11		
01317.0006	7	35184.0000	9	42652.0000	9		
01327.0000	13	35233.0000	9	42991.0000	9		
01330.0000	11	35249.0000	9	43663.0000	11		
01347.0000	13	35260.0000	13	43665.0000	11		
01359.0000	7	35574.1004	13	45723.0000	13		
01383.0000	7	35732.0000	7	47373.0000	11		
01383.0001	13	35770.0000	13	47455.0000	13		
01516.0000	13	35771.1000	7	M2547.0000	11		
01518.0000	9	35817.0000	7				
01522.0000	9	35818.0000	7				
01538.0000	11	35874.0001	7				
01539.0000	9	35906.0000	9				
01593.0000	9	36329.0000	13				
01686.0000	13	36372.0001	13				
02311.0000	5,9	36711.0000	7				
02313.0000	9	36801.0001	13				
02314.0000	9	36845.0000	7				
02327.0002	9	37204.0000	9				
02330.0001	9	37549.0001	11				
02370.0001	13	37711.0003	13				
02999.0000	5	37881.0000	5				
05752.0003	5	38278.0010	11				
05752.0004	5	38278.0011	13				
05816.0002	5	38278.0016	11				
05852.0001	9	38278.1002	11,13				
05861.1002	9	39072.1001	5				
05867.0000	9	39072.1002	5				
05870.0000	9	39075.1000	11				
05876.0000	7	39075.1001	11				
05881.0000	9	39191.0000	11				
05882.0000	9	39228.0003	11				
05884.0000	5	40701.0012	13				
05951.0000	9	41212.0003	7				
05954.0000	9	41212.0004	7				
05995.0000	9	41216.1000	5				
11029.1005	9	41216.1001	5				
11029.1006	9	41222.0000	7				
11180.0000	9	41223.0000	7				
11185.0001	9	41226.0000	7				
11191.0001	9	41226.0003	7				
11192.0000	9	41242.0000	7				