

BUNN®

FPG FPGA



ILLUSTRATED PARTS CATALOG

Designs, materials, weights, specifications, and dimensions for equipment or replacement parts are subject to change without notice.

BUNN-O-MATIC CORPORATION

POST OFFICE BOX 3227

SPRINGFIELD, ILLINOIS 62708-3227

PHONE: (217) 529-6601 FAX: (217) 529-6644



BUNN-O-MATIC COMMERCIAL PRODUCT WARRANTY

Bunn-O-Matic Corp. ("BUNN") warrants equipment manufactured by it as follows:

- 1) Airpots, thermal carafes, decanters, GPR servers, iced tea/coffee dispensers, MCR/MCP/MCA single cup brewers, thermal servers and ThermoFresh® servers (mechanical and digital) 1 year parts and 1 year labor.
- 2) All other equipment - 2 years parts and 1 year labor plus added warranties as specified below:
 - a) Electronic circuit and/or control boards - parts and labor for 3 years.
 - b) Compressors on refrigeration equipment - 5 years parts and 1 year labor.
 - c) Grinding burrs on coffee grinding equipment to grind coffee to meet original factory screen sieve analysis - parts and labor for 4 years or 40,000 pounds of coffee, whichever comes first.

These warranty periods run from the date of installation BUNN warrants that the equipment manufactured by it will be commercially free of defects in material and workmanship existing at the time of manufacture and appearing within the applicable warranty period. This warranty does not apply to any equipment, component or part that was not manufactured by BUNN or that, in BUNN's judgment, has been affected by misuse, neglect, alteration, improper installation or operation, improper maintenance or repair, non periodic cleaning and descaling, equipment failures related to poor water quality, damage or casualty. In addition, the warranty does not apply to replacement of items subject to normal use including but not limited to user replaceable parts such as seals and gaskets. This warranty is conditioned on the Buyer 1) giving BUNN prompt notice of any claim to be made under this warranty by telephone at (217) 529-6601 or by writing to Post Office Box 3227, Springfield, Illinois 62708-3227; 2) if requested by BUNN, shipping the defective equipment prepaid to an authorized BUNN service location; and 3) receiving prior authorization from BUNN that the defective equipment is under warranty.

THE FOREGOING WARRANTY IS EXCLUSIVE AND IS IN LIEU OF ANY OTHER WARRANTY, WRITTEN OR ORAL, EXPRESS OR IMPLIED, INCLUDING, BUT NOT LIMITED TO, ANY IMPLIED WARRANTY OF EITHER MERCHANTABILITY OR FITNESS FOR A PARTICULAR PURPOSE. The agents, dealers or employees of BUNN are not authorized to make modifications to this warranty or to make additional warranties that are binding on BUNN. Accordingly, statements by such individuals, whether oral or written, do not constitute warranties and should not be relied upon.

If BUNN determines in its sole discretion that the equipment does not conform to the warranty, BUNN, at its exclusive option while the equipment is under warranty, shall either 1) provide at no charge replacement parts and/or labor (during the applicable parts and labor warranty periods specified above) to repair the defective components, provided that this repair is done by a BUNN Authorized Service Representative; or 2) shall replace the equipment or refund the purchase price for the equipment.

THE BUYER'S REMEDY AGAINST BUNN FOR THE BREACH OF ANY OBLIGATION ARISING OUT OF THE SALE OF THIS EQUIPMENT, WHETHER DERIVED FROM WARRANTY OR OTHERWISE, SHALL BE LIMITED, AT BUNN'S SOLE OPTION AS SPECIFIED HEREIN, TO REPAIR, REPLACEMENT OR REFUND.

In no event shall BUNN be liable for any other damage or loss, including, but not limited to, lost profits, lost sales, loss of use of equipment, claims of Buyer's customers, cost of capital, cost of down time, cost of substitute equipment, facilities or services, or any other special, incidental or consequential damages.

392, A Partner You Can Count On, Air Infusion, AutoPOD, AXIOM, BrewLOGIC, BrewMETER, Brew Better Not Bitter, BrewWISE, BrewWIZARD, BUNN Espresso, BUNN Family Gourmet, BUNN Gourmet, BUNN Pour-O-Matic, BUNN, BUNN with the stylized red line, BUNNlink, Bunn-O-Matic, Bunn-O-Matic, BUNNserve, BUNNSERVE with the stylized wrench design, Cool Froth, DBC, Dr. Brew stylized Dr. design, Dual, Easy Pour, EasyClear, EasyGard, FlavorGard, Gourmet Ice, Gourmet Juice, High Intensity, iMIX, Infusion Series, Intellisteam, My Café, Phase Brew, PowerLogic, Quality Beverage Equipment Worldwide, Respect Earth, Respect Earth with the stylized leaf and coffee cherry design, Safety-Fresh, savemycoffee.com, Scale-Pro, Silver Series, Single, Smart Funnel, Smart Hopper, SmartWAVE, Soft Heat, SplashGard, The Mark of Quality in Beverage Equipment Worldwide, ThermoFresh, Titan, trifacta, TRIFECTA (stylized logo), Velocity Brew, Air Brew, Beverage Bar Creator, Beverage Profit Calculator, Brew better, not bitter., Build-A-Drink, BUNNSource, Coffee At Its Best, Cyclonic Heating System, Daypart, Digital Brewer Control, Element, Milk Texturing Fusion, Nothing Brews Like a BUNN, Picture Prompted Cleaning, Pouring Profits, Signature Series, Sure Tamp, Tea At Its Best, The Horizontal Red Line, Ultra are either trademarks or registered trademarks of Bunn-O-Matic Corporation. The commercial trifacta® brewer housing configuration is a trademark of Bunn-O-Matic Corporation.

TABLE OF CONTENTS

TITLE	PAGE NO.
Electrical and Operating Controls.....	8
Hopper and Lid Assembly.....	6
Housing and Panels.....	4
Motor, Burr Housing and Components	10
Numerical Index.....	12

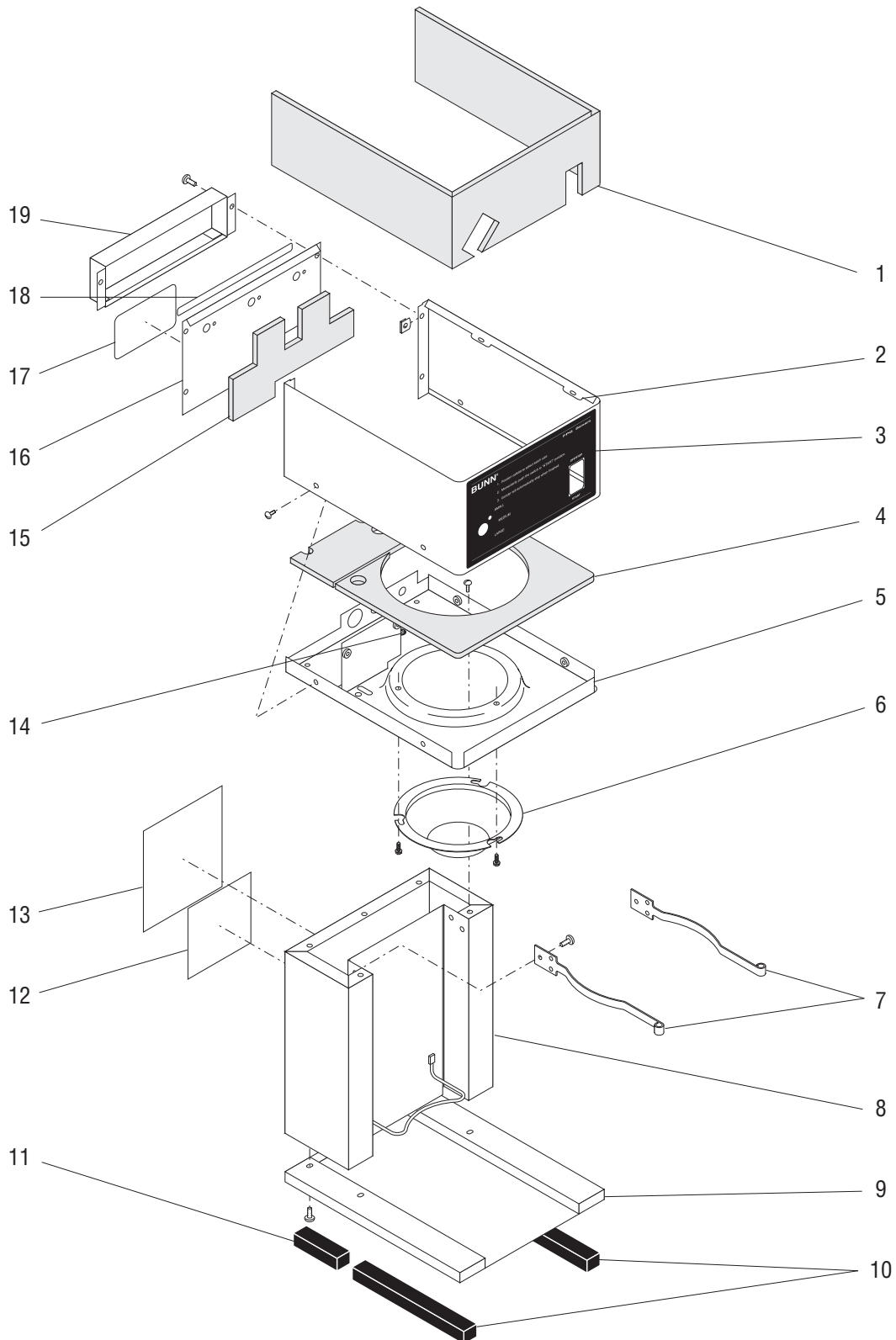

HOUSING AND PANELS

ITEM	PART NO.	QTY.	DESCRIPTION
1	20730.0002	1	Insulation, Hopper Housing
2	20573.0006	1	Housing, Hopper SST
	20573.0007*	1	Housing, Hopper BLK
	01315.0000	4	Screw, Truss Head SST #8-32 x .375"
	02322.0002	4	Screw, Truss Head BLK #8-32 x .375"
3	22303.0003	1	Decal, Hopper Housing
4	20727.0000	1	Insulation, Motor Support
5	20585.0000	1	Support, Motor (Also order items 4 and 14)
	02308.0000	5	Screw, Pan Head Serrated #8-32 x .38"
6	36512.0000	1	Outlet Funnel
	02311.0000	3	Screw, Hex Washer Head #10-32 x .50"
7	05839.0000	2	Rail, Funnel
	02308.0000	4	Screw, Pan Head #8-32 x .38"
8	20591.1004	1	Housing w/Decal, 120V (9.0" tall) SST (Includes items 12 and 13)
	20591.1003	1	Housing w/Decal, 230V (9.0" tall) SST (Includes item 12)
	20591.1005	1	Housing w/Decal, 230V (9.0" tall) BLK (Includes item 12)
9	20592.0003	1	Base. Formed SST
	20592.0004*	1	Base. Formed BLK
	01311.0001	4	Screw, Truss Head #8-32 x .25" LKG
10	20704.0001	2	Pad, Base W/Adhesive Back 6.38"
11	20704.0002	2	Pad, Base W/Adhesive Back 2.50"
12	20545.0000	1	Decal, Warning - Electrical
13	36781.0000	1	Schematic, Electrical (120V)
14	00824.0002	1	Decal, Ground
15	20729.0001	1	Insulation, Rear Panel
16	20617.1012	1	Panel W/Decal 120V SST (Includes items 15, 17 and 18)
	20617.1013	1	Panel W/Decal 230V SST (Includes items 15 and 18)
	20617.1015	1	Panel W/Decal 230V BLK (Includes items 15 and 18)
	01315.0000	4	Screw, Truss Head SST #8-32 x .375"
	02322.0002	4	Screw, Truss Head BLK #8-32 x .375"
	00917.0000	4	Fastener, "J" Type #8
17	37881.0000	1	Decal, No Serviceable Parts
18	36758.0000	1	Decal, Potentiometer 3 Position
19	28022.0000	1	Cover, Knob SST
	28022.0001	1	Cover, Knob BLK

* Indicates the part number listed is for reference only. See DESCRIPTION for possible service replacement.

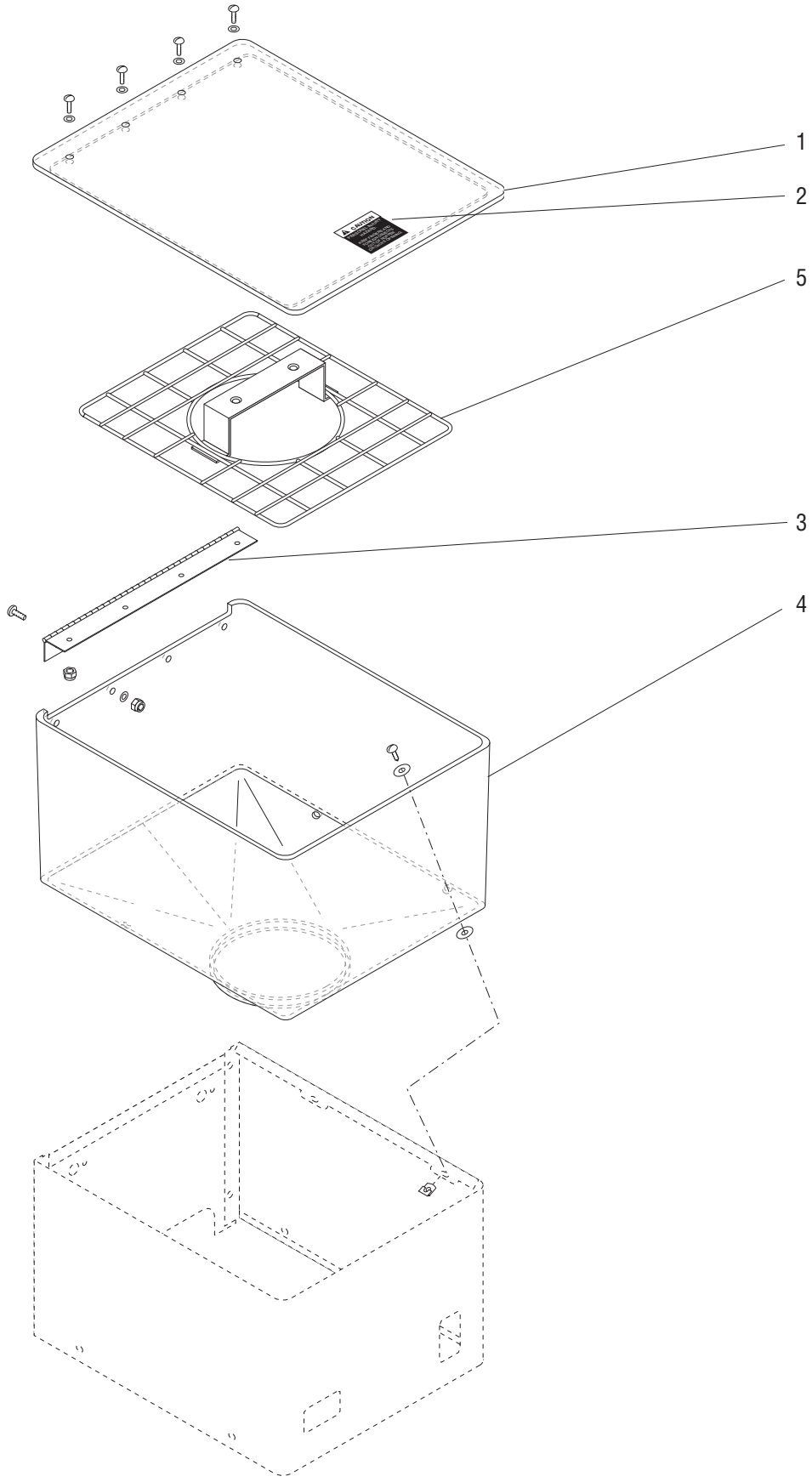

HOPPER AND LID ASSEMBLY

ITEM	PART NO.	QTY.	DESCRIPTION
-	21233.0000	1	Hopper/Lid Kit (Includes items 1 thru 4)
1	27218.0000	1	Lid w/Decal, Hopper (Includes item 2)
	01380.0000	4	Screw, Truss Head #6-32 x .50"
	21129.0000	4	Washer
	00991.0002	4	Nut, Elastic Lock #6-32
2	05876.0000	1	Decal, Caution
3	05966.0003	1	Hinge
	01380.0000	4	Screw, Truss Head #6-32 x .50"
	21129.0000	4	Washer
	00991.0002	4	Nut, Elastic Lock #6-32
4	20751.0002	1	Hopper
	01315.0000	4	Screw, Truss Head #8-32 x .375"
	01516.0001	8	Washer, Nylon-Retainer #8 x .50" O.D.
	00917.0000	4	Fastener, "J" Type #8
5	27101.0000	1	Guard, Hopper Burr
6	27119.0000	1	Hopper Burr Guard Kit (Includes item 5 and two 20609.0001 mounting screws)

* Indicates the part number listed is for reference only. See DESCRIPTION for possible service replacement.

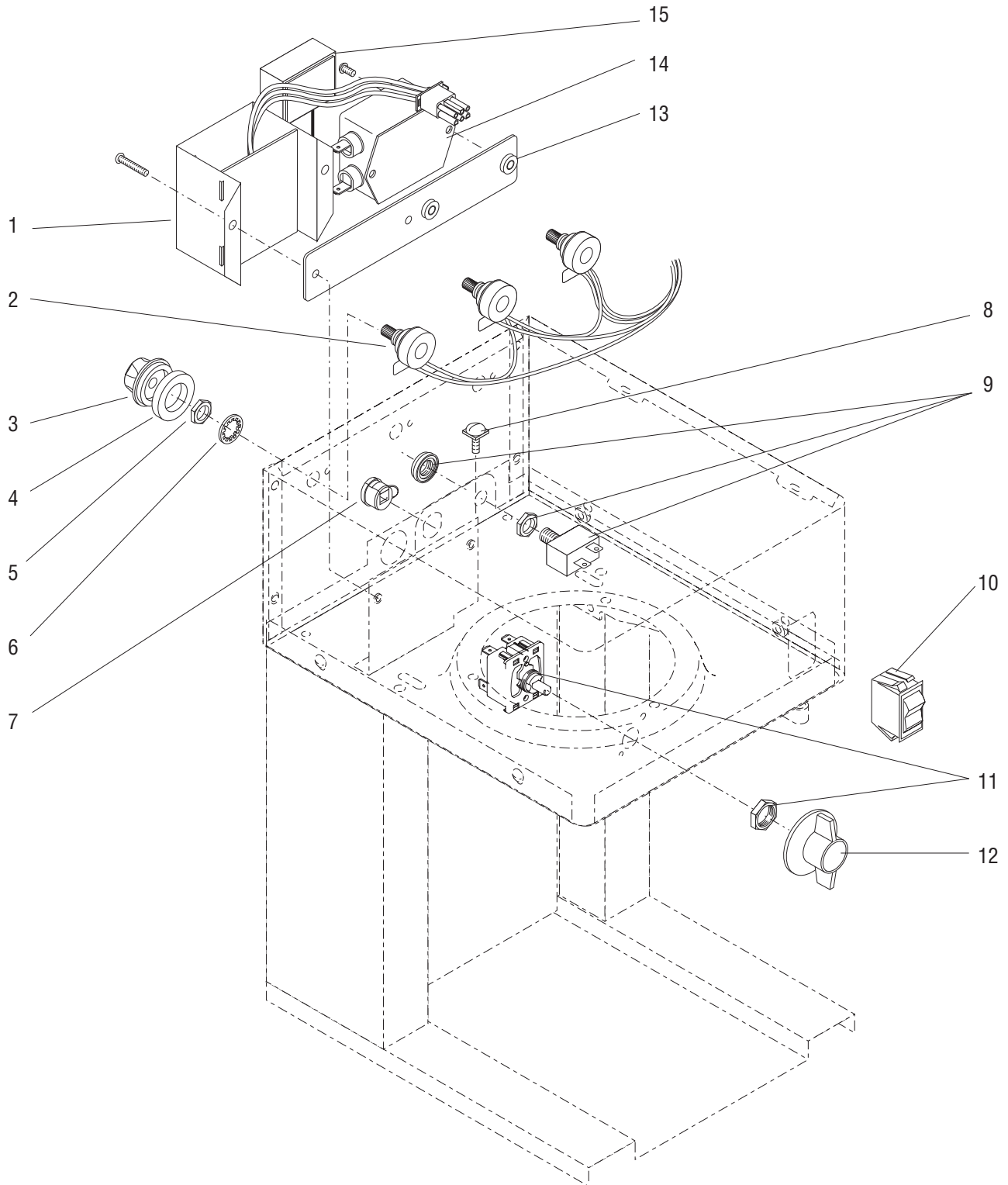

ELECTRICAL AND OPERATING CONTROLS

ITEM	PART NO.	QTY.	DESCRIPTION	
1	20529.1005	1	Timer 120V	
	20529.1006	1	Timer 230V	
	02308.0000	2	Screw, Truss Head #8-32 x .25"	
2	36802.0000	1	Wire Harness W/Potentiometers	
3	02239.0000	3	Knob, Potentiometer (Includes setscrew)	
	02248.0000	3	Washer, Adhesive backed	
4	02248.0000	3	Washer, Sponge Adhesive Back	
5	27348.0000	3	Nut .375" - 32	
6	01532.0001	3	Lockwasher, Internal tooth	
7	00707.0000	1	Bushing, Strain Relief (120V)	
	05746.0000	1	Bushing, Strain Relief (230V)	
8	01309.0000	1	Screw, Power Cord Ground, W/Terminal Washer #10-32 x .50" (120V)	
	01327.0000	1	Screw, Power Cord Ground #10-32 x .38" (230V)	
	01502.0000	1	Lockwasher #10 (230V)	
9	20987.1000	1	Circuit Breaker, 3 Amp	
10	05815.0000	1	Switch, OFF/ON/START	
11	36710.1000	1	Switch, Rotary 3 Position (Includes nut)	
	01383.0000	1	Screw, Pan Head #6-32 x .50"	
12	12246.0001	1	Knob, Rotary Switch	
	02338.0000	1	Setscrew #8-32 x .25"	
13	21878.0000	1	Plate, EMI Filter Mounting	} 230V models only
14	29446.0008	1	Filter, EMI	
	02308.0000	2	Screw, Truss Head #8-32 x .25"	
15	34808.0007	1	Capacitor, EMI Filter	
16	20630.0001	1	Cord Assy, Power (120V)	} Not Illustrated
	28111.0011	1	Cord Assy, Power (230V)	
16	20624.0000	1	Harness, Main Wiring (120)	
	20624.0003	1	Harness, Main Wiring (230V)	
17	20657.0000	1	Harness, Switch Wiring	

* Indicates the part number listed is for reference only. See DESCRIPTION for possible service replacement.

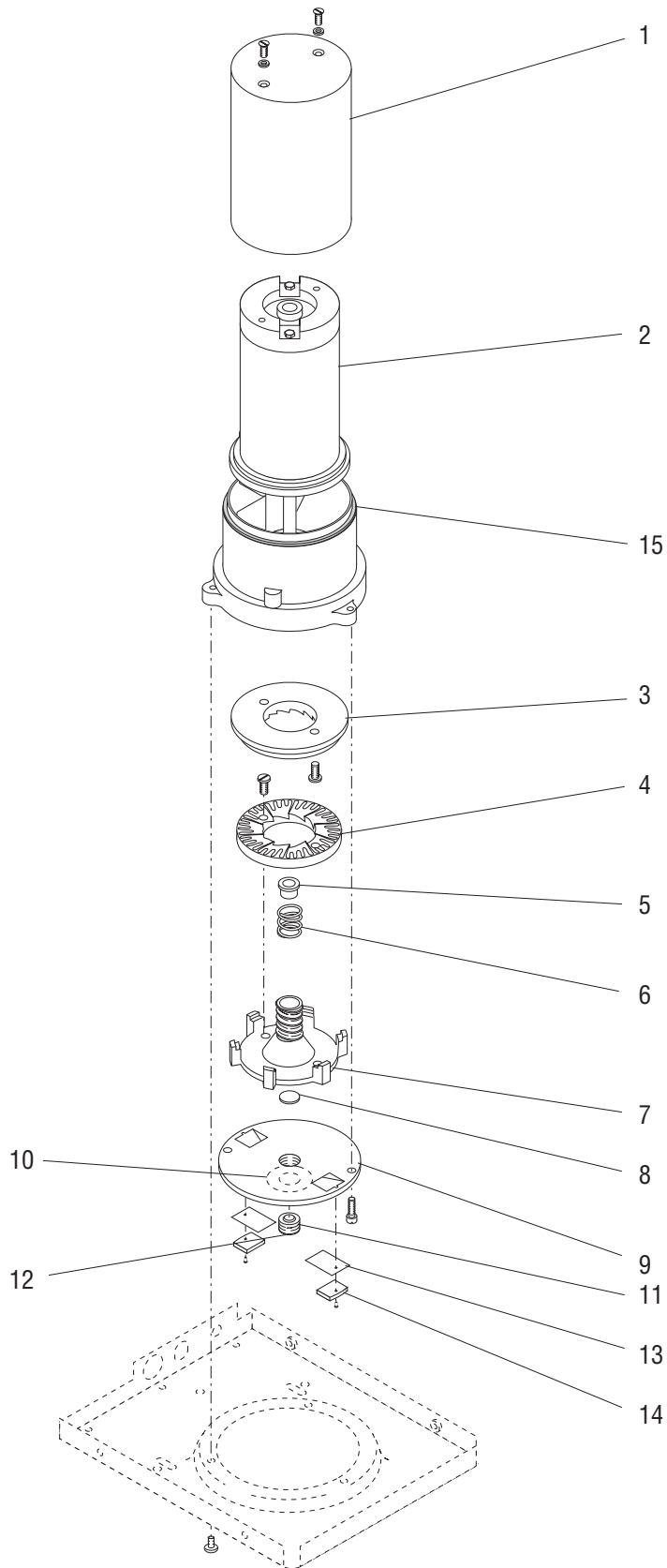

MOTOR, BURR HOUSING AND COMPONENTS

ITEM	PART NO.	QTY.	DESCRIPTION
-	20646.1004	1	Motor & Grinder Assy, High Output (120V) (Includes items 2 thru 15)
	20646.1003	1	Motor & Grinder Assy (230V) (Includes items 2 thru 15)
	02311.0000	3	Screw, Hex Washer Head #10-32 x .50"
1	20576.1001	1	Cover, Motor
	46032.0000	2	Screw, Hex Head #8-32 x .625"
	01547.0000	2	Spacer
2	20665.0000	1	Motor & Burr Housing Assy 120V
	20665.0002	1	Motor & Burr Housing Assy 230V
3	05859.0000*	1	Burr, Upper (Order item 16)
	20669.0000	2	Screw, Binding Head #10-32 x .29"
4	05860.0000*	1	Burr, Lower (Order item 16)
	20669.0000	2	Screw, Binding Head #10-32 x .29"
5	20667.0000	1	Bushing, Spring Retainer
6	20666.0000	1	Spring, Burr Rotor
7	20668.0001	1	Rotor Assy
8	20670.0000	1	Disc, Load
9	20673.1000	1	Cap, Burr Housing (Includes item 10)
	20672.0000	2	Screw, Fillister Head #10-32 x .625"
10	05880.0002	1	Decal, Grind Indicator
11	20671.1000	1	Screw, Burr Adjusting (Includes item 12)
12	05796.0000	1	Decal, Adjusting Screw
13	20588.0000	2	Spring Plate, Dechaffing
14	20572.0000	2	Support, Dechaffer
	02336.0001	2	Screw, Truss Head #4-40 x .312"
15	20611.0000	1	Gasket
16	05861.1002	-	Burr Kit (Includes items 3, 4 and Mounting Screws)
17	20620.0001	1	Burr Adjuster (Not Illustrated)

* Indicates the part number listed is for reference only. See DESCRIPTION for possible service replacement.

NUMERICAL INDEX

PART NO.	PAGE NO.	PART NO.	PAGE NO.	PART NO.	PAGE NO.	PART NO.	PAGE NO.
00707.0000.....	9	20630.0001.....	9				
00824.0002.....	5	20646.1003.....	11				
00917.0000.....	5,7	20646.1004.....	11				
00991.0002.....	7	20657.0000.....	9				
01309.0000.....	9	20665.0000.....	11				
01311.0001.....	5	20665.0002.....	11				
01315.0000.....	5,7	20666.0000.....	11				
01327.0000.....	9	20667.0000.....	11				
01380.0000.....	7	20668.0001.....	11				
01383.0000.....	9	20669.0000.....	11				
01502.0000.....	9	20670.0000.....	11				
01516.0001.....	7	20671.1000.....	11				
01532.0001.....	9	20672.0000.....	11				
01547.0000.....	11	20673.1000.....	11				
02239.0000.....	9	20704.0001.....	5				
02248.0000.....	9	20704.0002.....	5				
02308.0000.....	5,9	20727.0000.....	5				
02311.0000.....	5,11	20729.0001.....	5				
02322.0002.....	5	20730.0002.....	5				
02336.0001.....	11	20751.0002.....	7				
02338.0000.....	9	20987.1000.....	9				
05746.0000.....	9	21129.0000.....	7				
05796.0000.....	11	21233.0000.....	7				
05815.0000.....	9	21878.0000.....	9				
05839.0000.....	5	22303.0003.....	5				
05859.0000.....	11	27101.0000.....	7				
05860.0000.....	11	27119.0000.....	7				
05861.1002.....	11	27218.0000.....	7				
05876.0000.....	7	27348.0000.....	9				
05880.0002.....	11	28022.0000.....	5				
05966.0003.....	7	28022.0001.....	5				
12246.0001.....	9	28111.0011.....	9				
20529.1005.....	9	29446.0008.....	9				
20529.1006.....	9	34808.0007.....	9				
20545.0000.....	5	36512.0000.....	5				
20572.0000.....	11	36710.1000.....	9				
20573.0006.....	5	36758.0000.....	5				
20573.0007.....	5	36781.0000.....	5				
20576.1001.....	11	36802.0000.....	9				
20585.0000.....	5	37881.0000.....	5				
20588.0000.....	11	46032.0000.....	11				
20591.1003.....	5						
20591.1004.....	5						
20591.1005.....	5						
20592.0003.....	5						
20592.0004.....	5						
20611.0000.....	11						
20617.1012.....	5						
20617.1013.....	5						
20617.1015.....	5						
20620.0001.....	11						
20624.0000.....	9						
20624.0003.....	9						