

BUNN®

DUAL® SH DBC® *.5 & 1.0 Gallon*

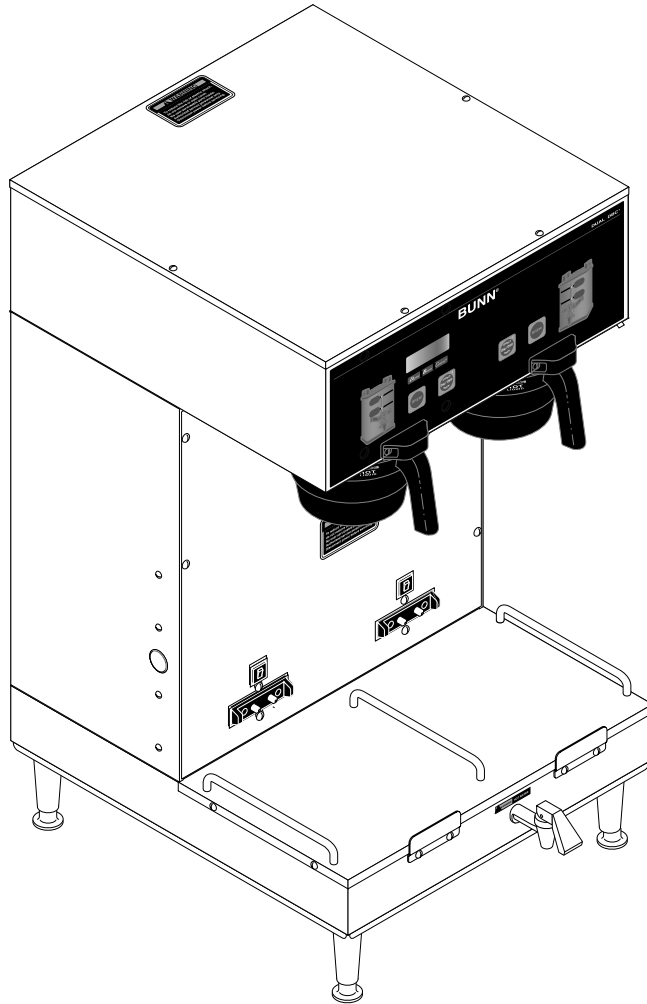

ILLUSTRATED PARTS CATALOG

Designs, materials, weights, specifications, and dimensions for equipment or replacement parts are subject to change without notice.

BUNN-O-MATIC CORPORATION

POST OFFICE BOX 3227

SPRINGFIELD, ILLINOIS 62708-3227

PHONE: (217) 529-6601 FAX: (217) 529-6644

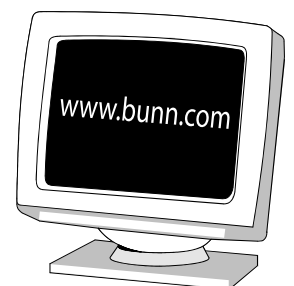

BUNN-O-MATIC COMMERCIAL PRODUCT WARRANTY

Bunn-O-Matic Corp. ("BUNN") warrants equipment manufactured by it as follows:

- 1) Airpots, thermal carafes, decanters, GPR servers, iced tea/coffee dispensers, MCR/MCP/MCA single cup brewers, thermal servers and ThermoFresh® servers (mechanical and digital) 1 year parts and 1 year labor.
- 2) All other equipment - 2 years parts and 1 year labor plus added warranties as specified below:
 - a) Electronic circuit and/or control boards - parts and labor for 3 years.
 - b) Compressors on refrigeration equipment - 5 years parts and 1 year labor.
 - c) Grinding burrs on coffee grinding equipment to grind coffee to meet original factory screen sieve analysis - parts and labor for 4 years or 40,000 pounds of coffee, whichever comes first.

These warranty periods run from the date of installation BUNN warrants that the equipment manufactured by it will be commercially free of defects in material and workmanship existing at the time of manufacture and appearing within the applicable warranty period. This warranty does not apply to any equipment, component or part that was not manufactured by BUNN or that, in BUNN's judgment, has been affected by misuse, neglect, alteration, improper installation or operation, improper maintenance or repair, non periodic cleaning and descaling, equipment failures related to poor water quality, damage or casualty. In addition, the warranty does not apply to replacement of items subject to normal use including but not limited to user replaceable parts such as seals and gaskets. This warranty is conditioned on the Buyer 1) giving BUNN prompt notice of any claim to be made under this warranty by telephone at (217) 529-6601 or by writing to Post Office Box 3227, Springfield, Illinois 62708-3227; 2) if requested by BUNN, shipping the defective equipment prepaid to an authorized BUNN service location; and 3) receiving prior authorization from BUNN that the defective equipment is under warranty.

THE FOREGOING WARRANTY IS EXCLUSIVE AND IS IN LIEU OF ANY OTHER WARRANTY, WRITTEN OR ORAL, EXPRESS OR IMPLIED, INCLUDING, BUT NOT LIMITED TO, ANY IMPLIED WARRANTY OF EITHER MERCHANTABILITY OR FITNESS FOR A PARTICULAR PURPOSE. The agents, dealers or employees of BUNN are not authorized to make modifications to this warranty or to make additional warranties that are binding on BUNN. Accordingly, statements by such individuals, whether oral or written, do not constitute warranties and should not be relied upon.

If BUNN determines in its sole discretion that the equipment does not conform to the warranty, BUNN, at its exclusive option while the equipment is under warranty, shall either 1) provide at no charge replacement parts and/or labor (during the applicable parts and labor warranty periods specified above) to repair the defective components, provided that this repair is done by a BUNN Authorized Service Representative; or 2) shall replace the equipment or refund the purchase price for the equipment.

THE BUYER'S REMEDY AGAINST BUNN FOR THE BREACH OF ANY OBLIGATION ARISING OUT OF THE SALE OF THIS EQUIPMENT, WHETHER DERIVED FROM WARRANTY OR OTHERWISE, SHALL BE LIMITED, AT BUNN'S SOLE OPTION AS SPECIFIED HEREIN, TO REPAIR, REPLACEMENT OR REFUND.

In no event shall BUNN be liable for any other damage or loss, including, but not limited to, lost profits, lost sales, loss of use of equipment, claims of Buyer's customers, cost of capital, cost of down time, cost of substitute equipment, facilities or services, or any other special, incidental or consequential damages.

392, A Partner You Can Count On, Air Infusion, AutoPOD, AXIOM, BrewLOGIC, BrewMETER, Brew Better Not Bitter, BrewWISE, BrewWIZARD, BUNN Espresso, BUNN Family Gourmet, BUNN Gourmet, BUNN Pour-O-Matic, BUNN, BUNN with the stylized red line, BUNNlink, Bunn-O-Matic, Bunn-O-Matic, BUNNserve, BUNNSERVE with the stylized wrench design, Cool Froth, DBC, Dr. Brew stylized Dr. design, Dual, Easy Pour, EasyClear, EasyGard, FlavorGard, Gourmet Ice, Gourmet Juice, High Intensity, iMIX, Infusion Series, Intellisteam, My Café, Phase Brew, PowerLogic, Quality Beverage Equipment Worldwide, Respect Earth, Respect Earth with the stylized leaf and coffee cherry design, Safety-Fresh, savemycoffee.com, Scale-Pro, Silver Series, Single, Smart Funnel, Smart Hopper, SmartWAVE, Soft Heat, SplashGard, The Mark of Quality in Beverage Equipment Worldwide, ThermoFresh, Titan, trifacta, TRIFECTA (stylized logo), Velocity Brew, Air Brew, Beverage Bar Creator, Beverage Profit Calculator, Brew better, not bitter., Build-A-Drink, BUNNSource, Coffee At Its Best, Cyclonic Heating System, Daypart, Digital Brewer Control, Element, Milk Texturing Fusion, Nothing Brews Like a BUNN, Picture Prompted Cleaning, Pouring Profits, Signature Series, Sure Tamp, Tea At Its Best, The Horizontal Red Line, Ultra are either trademarks or registered trademarks of Bunn-O-Matic Corporation. The commercial trifacta® brewer housing configuration is a trademark of Bunn-O-Matic Corporation.

TABLE OF CONTENTS

Base - Trunk - Hood - Covers & Panels	4
Dispense Valve and Sprayhead.....	14
Electrical Controls	18
Faucet.....	16
Funnel.....	22
Numerical Index	24
Strainer, Solenoid & Lines.....	10
Tank and Mounting Brackets	8
Tank Heater & Overflow Protection Devices	6
Water By-Pass.....	12

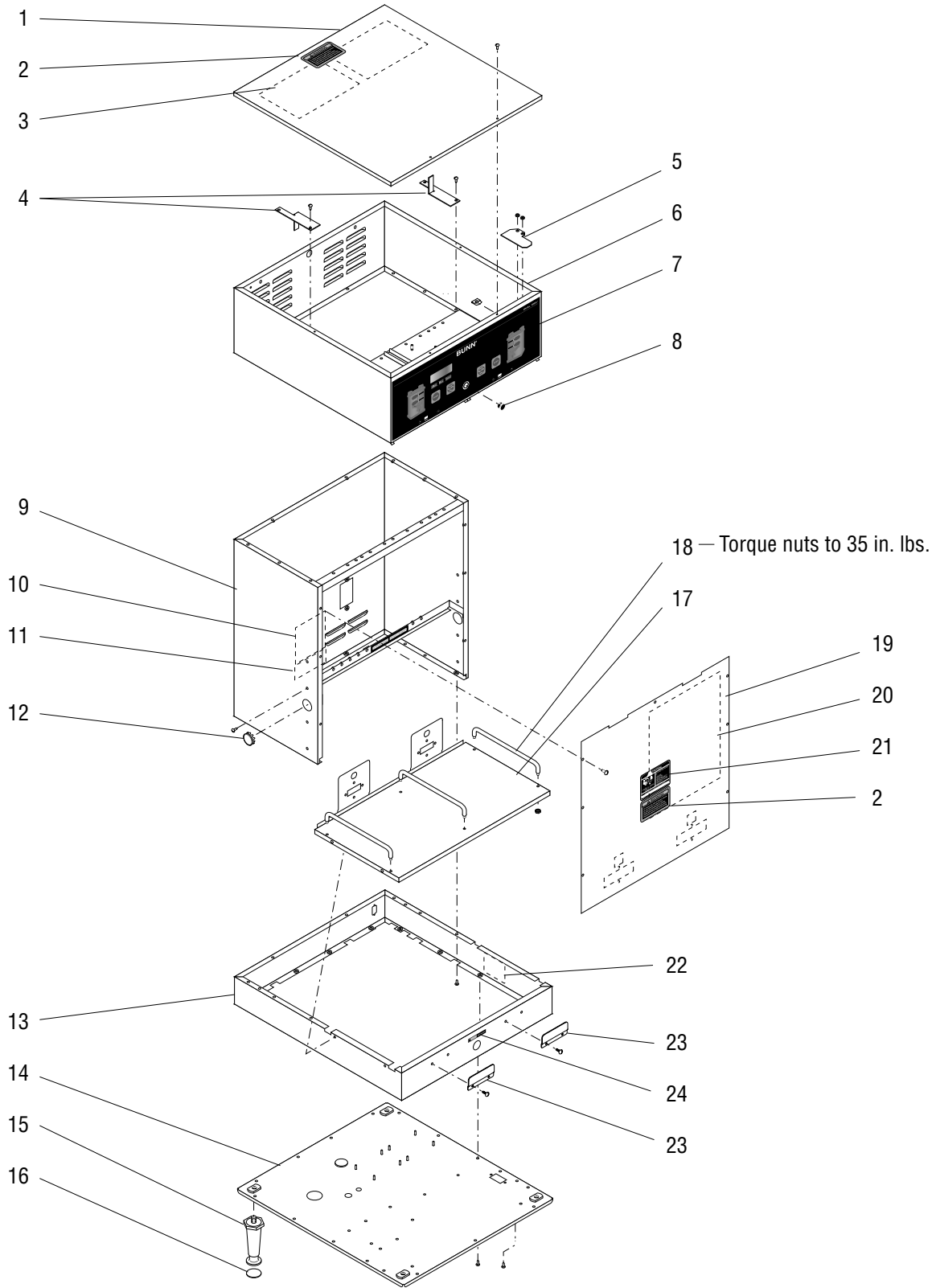

BASE - TRUNK - HOOD - COVERS & PANELS

ITEM	PART NO.	QTY.	DESCRIPTION
1	25376.0002	1	Cover Assy, Top BLK (Includes item 2 & 3)
	02336.0002	4	Screw, Truss Head BLK #4 - 40 x .38"
	00916.0000	4	Clip, J-Type #4-40
2	33871.0000	2	Decal, Warning "No Serviceable Parts"
3	25151.0000	2	Shield, Insulator
4	26949.0001	2	Bracket, Tank Supporting
5	32649.0000	2	Plate
	00970.0000	4	Nut, Keps #8-32 } Models without Funnel Locks
6	35388.0006*	1	Hood
	02308.0000	16	Screw, Pn-Hd #8 - 32 x .375"
7	29974.0007	1	Switch, Membrane
8	05749.0004	1	Plug, Hole .50" Dia. (Models with Lower Faucet)
9	35160.1000	1	Trunk W/Decals (Includes items 10, & 11)
10	00986.0000	1	Decal, Warning - Electrical
11	00656.0001	1	Decal, Comply to Plumbing Code
12	00619.0005	-	Plug, Hole 1.06" Dia (Use as required)
13	35334.0000	1	Base Housing
	02308.0000	8	Screw, Pan Head #8 - 32 x .375"
14	38936.0007	1	Cover, Bottom
	02308.0000	15	Screw, Pan Head #8 - 32 x .375"
15	26528.0000	4	Leg, 4.0" SST Adjustable
16	03996.0000	4	Pad, Anti Skid
17	12249.0001	3	Guide Rail SST
	00970.0000	6	Nut, Keps #8 - 32
18	27760.0002	1	Cover, Server Platform
	01382.0003	4	Screw, Truss Head #6 - 32 x .375"
19	35158.1000	1	Panel W/Decals, Trunk (Includes items 2, 20, & 21)
	01382.0003	11	Screw, Truss Head #6 - 32 x .375"
20	29876.0015	1	Schematic, 120V
21	00658.0000	1	Decal, Caution - Decanter/Funnel
22	39803.0000	1	Decal, Main Switc h
23	21537.0001	2	Plate, Server Stop SST
	01347.0000	4	Screw, Truss Head SST #6-32 x .38"
24	20201.5600	1	Decal, Warning - Hot Water

* Indicates the part number listed is for reference only. See DESCRIPTION for possible service replacement.

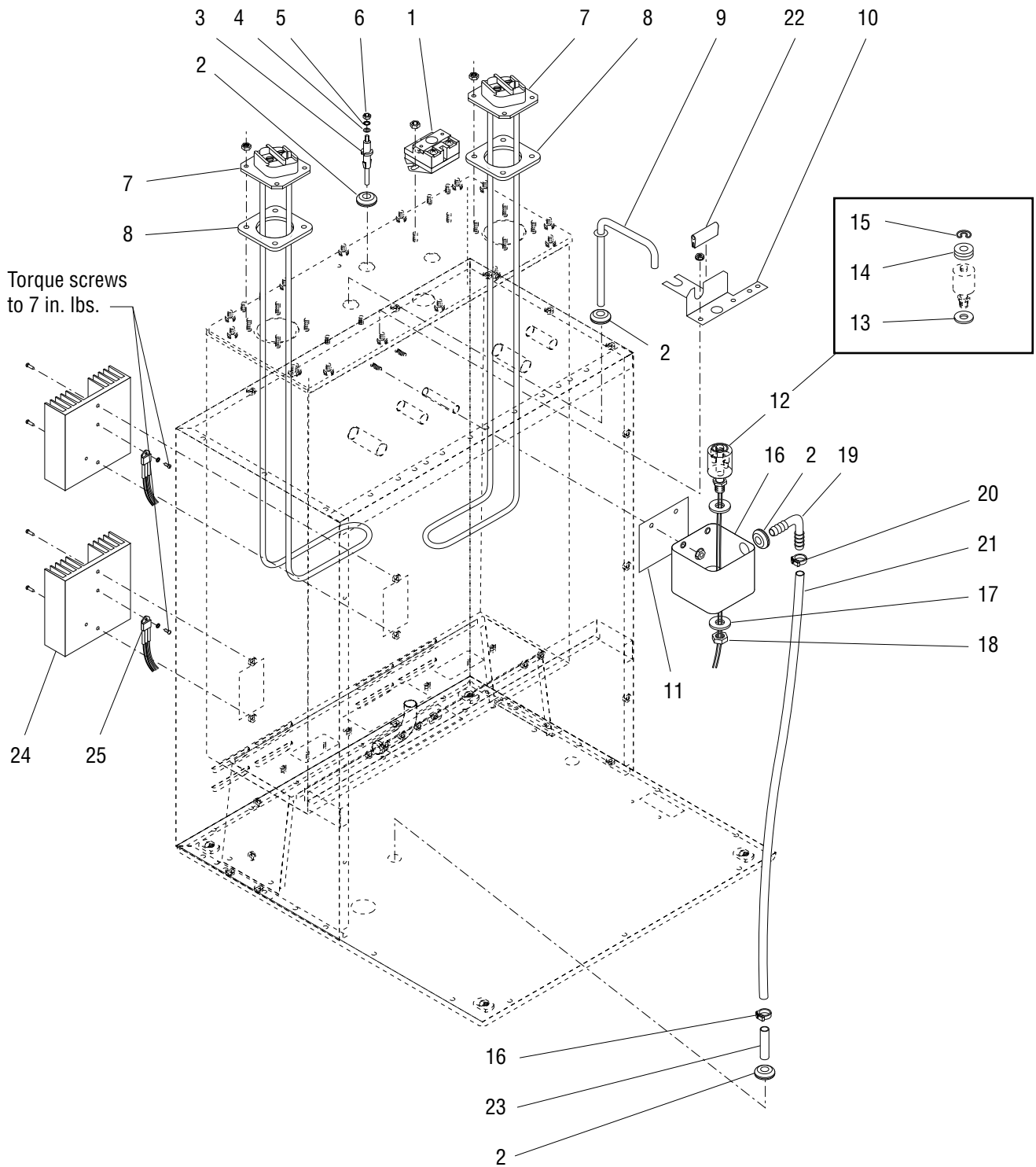

TANK HEATER & OVERFLOW PROTECTION DEVICES

ITEM	PART NO.	QTY.	DESCRIPTION
1	23717.0003 00908.0000	2 4	Thermostat, Limit Nut, Hex #8 - 32
2	02536.0000	3	Grommet .375" I.D.
3	20936.1000	1	Probe Kit (Includes items 4, 5 & 6)
4	01501.0000	1	Washer .164" I.D. x .375" O.D.
5	20203.0100	1	Lockwasher, Internal Tooth #8
6	00908.0000	1	Nut, Hex #8 - 32
7	20922.1000 00908.0000	2 8	Tank Heater, 3300W @ 240V (Includes item 8) Nut, Hex #8 - 32
8	12398.0002	2	Gasket, Tank Heater
9	26622.0001	1	Tube Assy, Vent
10	27473.0000	1	Bracket, Overflow Cup Mounting
11	41266.0000	1	Film, Insulating
12	03803.0000 00946.0000	1 1	Switch Assy, Liquid Level, 120V (Includes items 13, 14 & 15) Nut, Hex .125" FPT
13	03633.0000	2	Gasket, Float Switch (Only 1 used in this application)
14	-----	3	Washer, Adjusting (DO NOT USE IN THIS APPLICATION)
15	03807.0000	1	Clip, Spring
16	41259.1003 00971.0000	1 2	Kit, Overflow Cup (Aluminum) (Includes items 2,11, 17 &19) Nut, Keps #10 - 32
17	04797.0000	1	Washer, Celcon .520" I.D. x 1.0" O.D.
18	00946.0000	1	Nut, Hex .125" FPT
19	41280.0001	1	Elbow,.375" Multi Barb
20	12422.0000	2	Clamp, Hose .47"/.54" I.D.
21	03236.0007*	1	Tube, Silicone .312" I.D. x 25" (Order item 24)
22	02434.0010*	1	U-Channel 2.0" (Order item 23)
23	21801.0002	1	Tube .375" O.D.
24	20541.0001 01382.0007	2 4	Heat Sink (Also order item 26) Screw, Truss Head 6-32 x .38"
25	12565.0028 02328.0003 01520.0000	2 2 2	Triac Assy, 40 amp, 120V Screw, Pan Head #6-32 x .312" Lockwasher #6
26	M2522.1000	-	Heat Sink Compound
27	02434.1000	-	U-Channel 18.0" (Use as required)
28	03236.1001 03236.1003 03236.1002	- - -	Tube, Silicone .312" I.D. x 36.0" Tube, Silicone .312" I.D. x 60.0" Tube, Silicone .312" I.D. x 120.0"
29	03851.0000	2	Wire Nut

Not illustrated

* Indicates the part number listed is for reference only. See DESCRIPTION for possible service replacement.

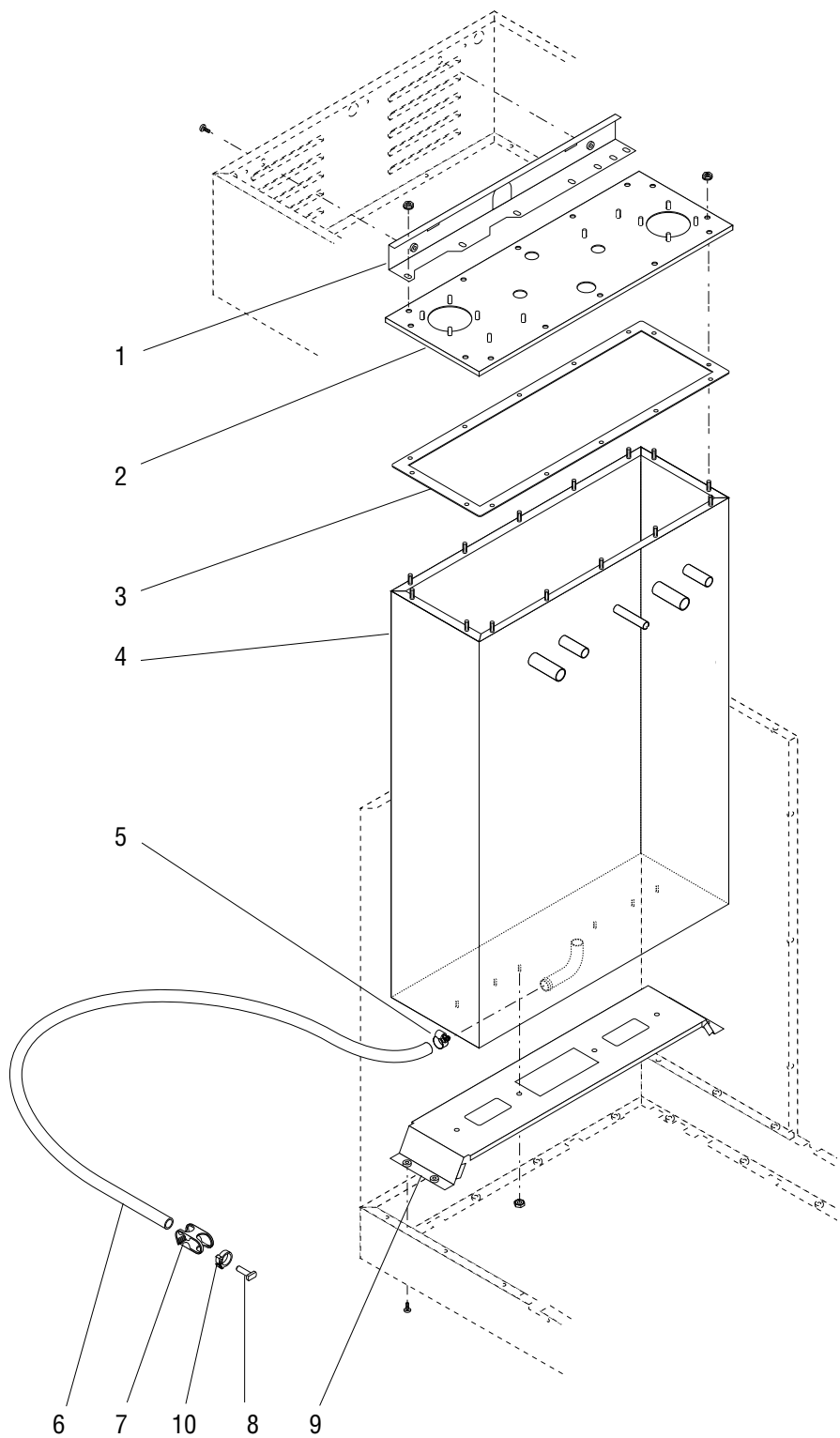

TANK AND MOUNTING BRACKETS

ITEM	PART NO.	QTY.	DESCRIPTION
1	37526.0000	1	Bracket, Tank Support (Top)
	02308.0000	2	Screw, Pan Head #8 - 32 x .375"
	00908.0000	2	Nut, Hex #8 - 32
2	20881.0001	1	Lid, Tank
	00908.0000	14	Nut, Hex #8 - 32
3	20883.0000	1	Gasket, Tank
4	20878.1008	1	Tank
5	29421.0000	1	Clamp, Hose-Worm Drive .625"/.75"
6	32591.0011*	1	Tube, Silicone .50" I.D. x 36" LG (Order item 11)
7	11630.0001	1	Clamp, Tubing Shut Off .75" O.D.
8	35086.0000	1	Plug, .50" I.D. Hose
9	35162.0000	1	Bracket, Tank Mounting (Bottom)
	00971.0000	4	Nut, Keps #10 - 32
	02308.0000	4	Screw, Pan Head #8 - 32 x .375"
10	12422.0009	1	Clamp, Hose .71"/.80" I.D.
11	32591.1002	-	Tube, Silicone .50" I.D. x 36.0" LG

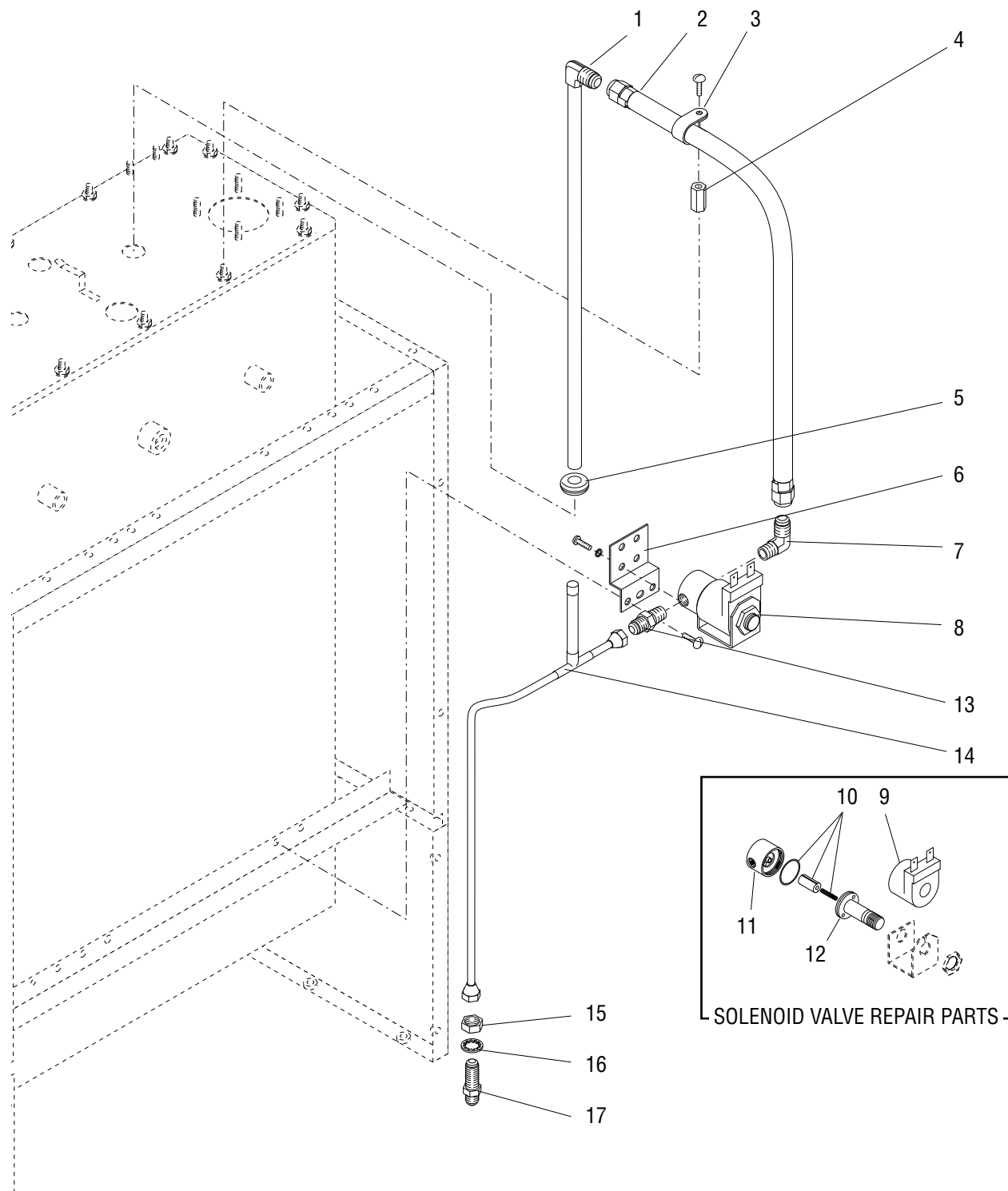

STRAINER, SOLENOID & LINES

ITEM	PART NO.	QTY.	DESCRIPTION
1	20937.0000	1	Tube, Tank Fill
2	20977.1000	1	Hose Assy, Solenoid to Tank
3	00620.0000	1	Clamp, Hose Retaining
	02308.0000	1	Screw, Pan Head #8 - 32 x .375"
4	00950.0000	1	Spacer, Hose Clamp
5	02536.0000	1	Grommet .375" I.D.
6	20201.4301	1	Bracket, Solenoid Mounting, 120/240V
	02308.0000	2	Screw, Pan Head #8 - 32 x .375"
7	00400.0001	1	Elbow, Male .250" Flare x .125" MPT
8	01085.0006	1	Solenoid Valve Assy, 120V (Includes items 9 - 12)
	01327.0000	2	Screw, Pan Head #10 - 32 x .375"
	01502.0000	2	Lockwasher, Split #10
9	01101.0000	1	Solenoid Valve Coil, 120V
10	01111.0000	1	Solenoid Valve Repair Kit, 120V (Includes Plunger, Seal and Spring)
11	01079.0000	1	Solenoid Valve Base
12	01116.0000	1	Sleeve Assy, Solenoid Valve
13	00402.0001	1	Connector .250" Flare x .125" MPT
14	25134.0001	1	Tube Assy, Strainer to Solenoid
15	00463.0000	1	Nut, Hex .438" - 20
16	01532.0000	1	Lockwasher, Internal Tooth .438" I.D.
17	00459.0000	1	Bulkhead Fitting .250" Flare

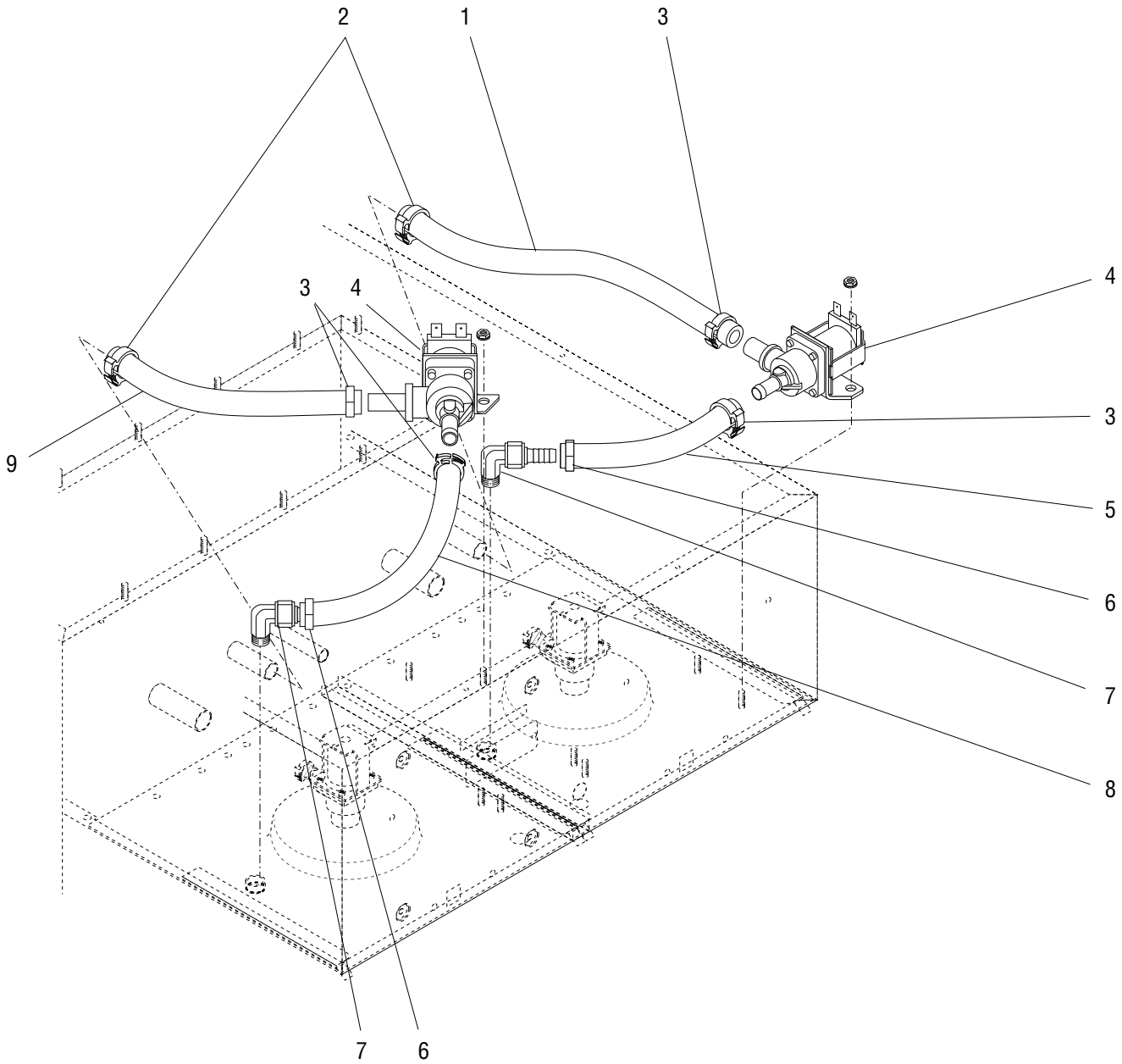

WATER BY-PASS

ITEM	PART NO.	QTY.	DESCRIPTION
1	32591.0007*	1	Tube, Silicone .50" I.D. x 8.75" (Order item 11)
2	12422.0009	2	Clamp, Hose .71"/.80" I.D.
3	12422.0005	4	Clamp, Hose .61"/.71" I.D.
4	27370.0000	2	Valve Assy, By-Pass 120V
	00970.0000	4	Nut, Keps #8 - 32
5	20976.0006*	1	Tube, Silicone .375" I.D. x 4.25" (Order item 10)
6	12422.0001	2	Clamp, Hose .59"/.66" I.D.
7	32648.0000	2	Elbow, Compression
8	20976.0003*	1	Tube, Silicone .375" I.D. x 9.25" (Order item 10)
9	32591.0009*	1	Tube, Silicone .50" I.D. x 5.25" (Order item 11)
10	20976.1000	-	Tube, Silicone .375" I.D. x 12.0" rowspan="4">} Not illustrated
	20976.1001	-	Tube, Silicone .375" I.D. x 36.0"
	20976.1002	-	Tube, Silicone .375" I.D. x 120.0"
11	32591.1000	-	Tube, Silicone .50" I.D. x 36.0"

* Indicates the part number listed is for reference only. See DESCRIPTION for possible service replacement.

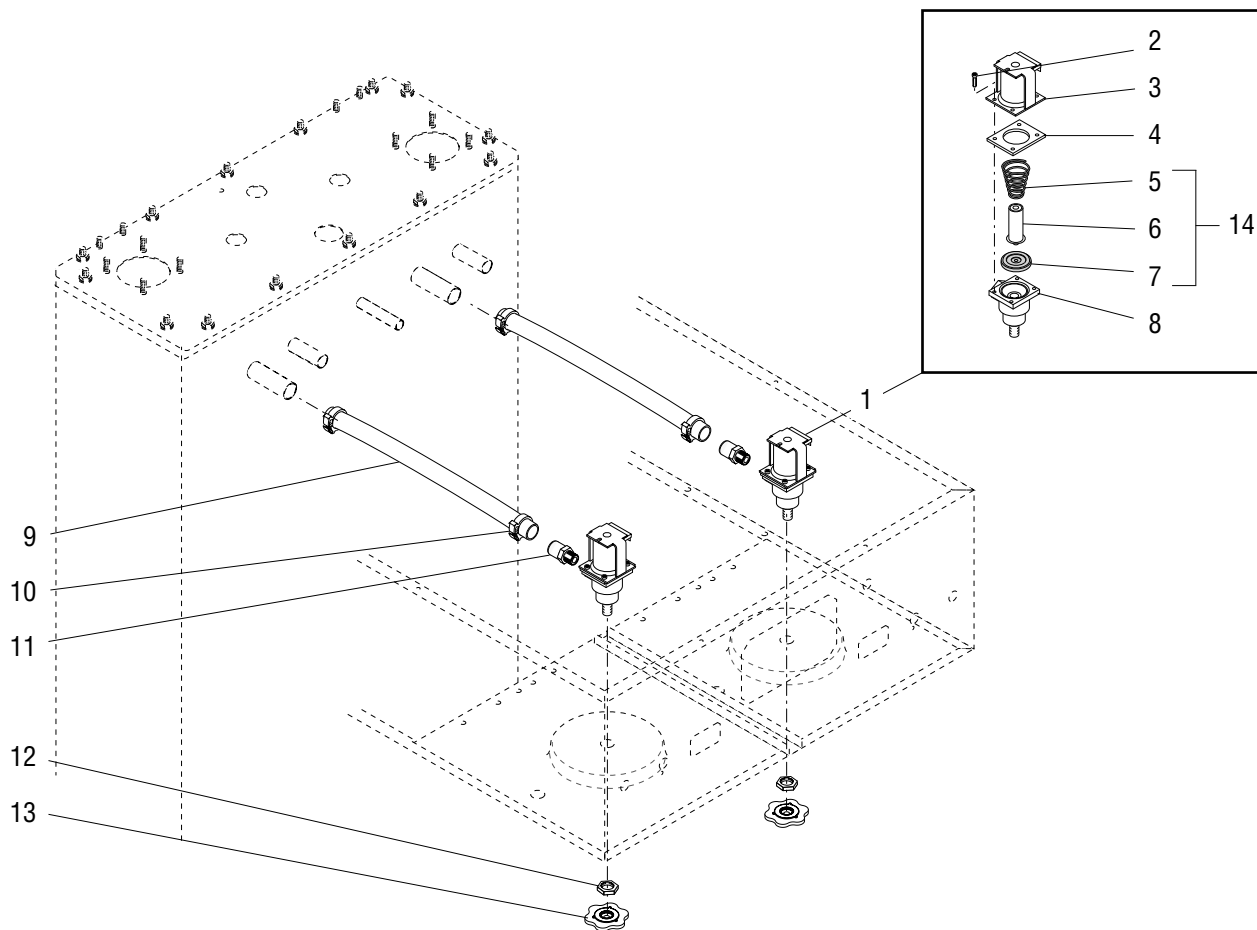

DISPENSE VALVE & SPRAYHEAD

ITEM	PART NO.	QTY.	DESCRIPTION
1	26846.0000	2	Valve Assy, Sprayhead 120V models (Includes items 2 thru 8)
2	23254.0000	4	Screw, #8 - 32
3	22305.0000	1	Coil Assy, Dispensing Valve 120V models
4	23256.0000	1	Spacer Plate
5	-----	1	Spring (Not available order item 14)
6	-----	1	Plunger (Not available order item 14)
7	23255.0000	1	Diaphragm
8	-----	1	Body (Not available order item 1)
9	35052.0001*	2	Tube, Silicone .75" I.D. x 6.75" (Order item 16)
10	12422.0008	4	Clamp, Hose .93"/1.1" I.D.
11	34956.0011	2	Fitting, .25" NPTF .281" I.D.
12	01075.0000	2	Nut, Hex .438" - 20
13	40670.0012	2	Sprayhead, Black .201" 7 Hole
14	11517.0008	-	Valve Repair Kit (Includes one each of items 5, 6 & 7)
15	35052.1000	1	Tube, Silicone .75" I.D. x 12.0" (Not illustrated)

* Indicates the part number listed is for reference only. See DESCRIPTION for possible service replacement.

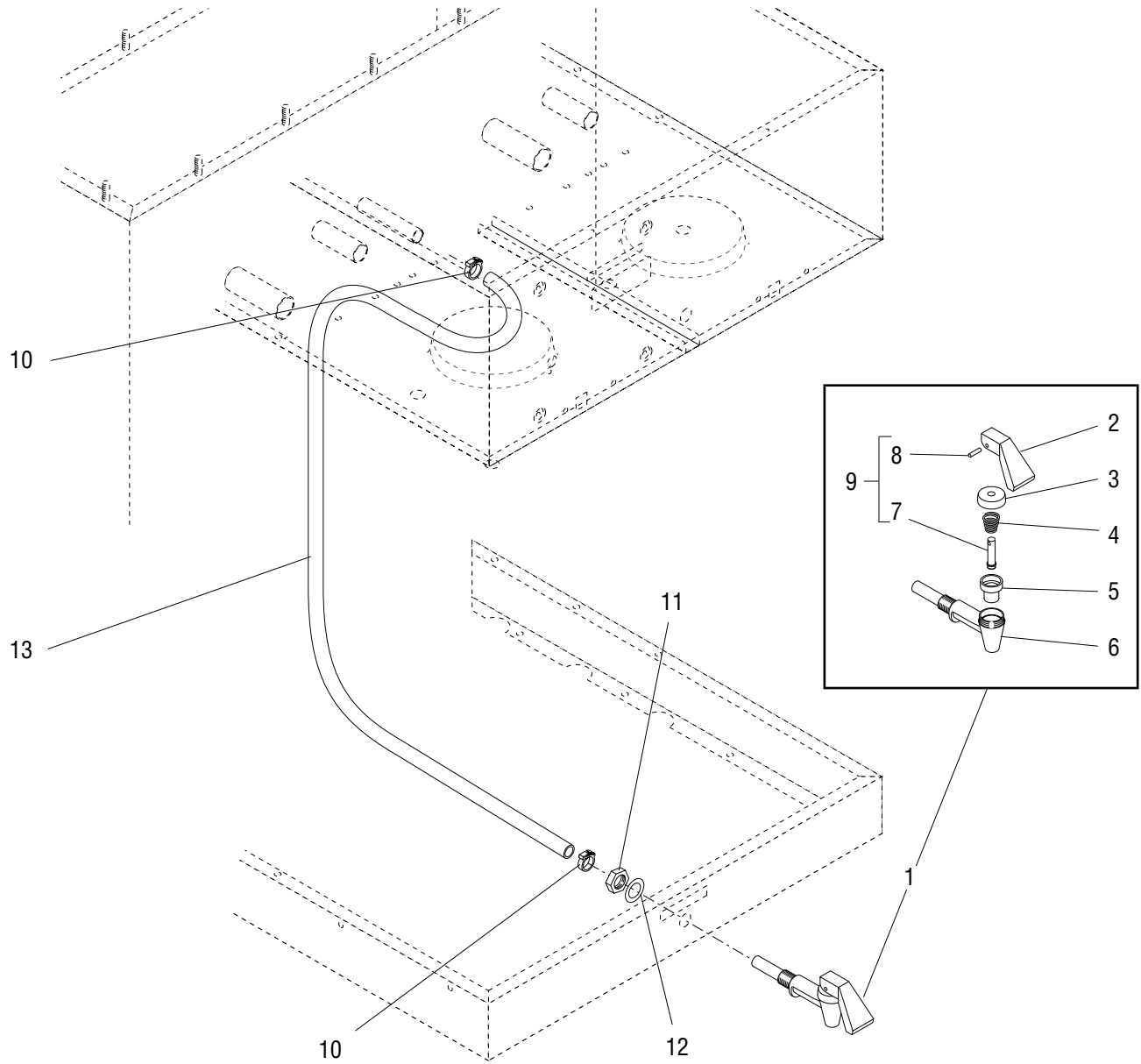

FAUCET

ITEM	PART NO.	QTY.	DESCRIPTION
1	29075.0000	1	Faucet Assy (Includes items 2 thru 9)
2	02861.0000	1	Handle, Faucet
3	02854.0000	1	Bonnet, Faucet
4	02595.0000	1	Spring, Faucet
5	02766.0000	1	Seat Cup, Faucet
6	02856.0002	1	Body, Faucet
7	13054.0000	1	Stem, Faucet
8	02858.0000	1	Pin, Spring .125" Dia. x .50"
9	02594.0000	1	Faucet Stem W/Pin (Includes items 7 & 8)
10	12422.0001	2	Clamp, Hose .59" x .66" I.D.
11	29264.0000	1	Nut, Faucet Retaining
12	01532.0005	1	Washer, Intl Tooth .50" Lock
13	20976.0036*	1	Tube, Silicone .38" I.D. x .62" O.D. x 36.0" (Order Item 14)
14	20976.1000	1	Tube, Silicone .38" I.D. x .62" O.D. x 12.0"
	20976.1001	1	Tube, Silicone .38" I.D. x .62" O.D. x 36.0"
	20976.1002	1	Tube, Silicone .38" I.D. x .62" O.D. x 120.0"
16	28706.0002	-	Faucet Kit (Includes items 2,4,5, 7 & 8)
17	M2517.0000	-	Sealant, Pipe 6 ml

Not Illustrated

* Indicates the part number listed is for reference only. See DESCRIPTION for possible service replacement.

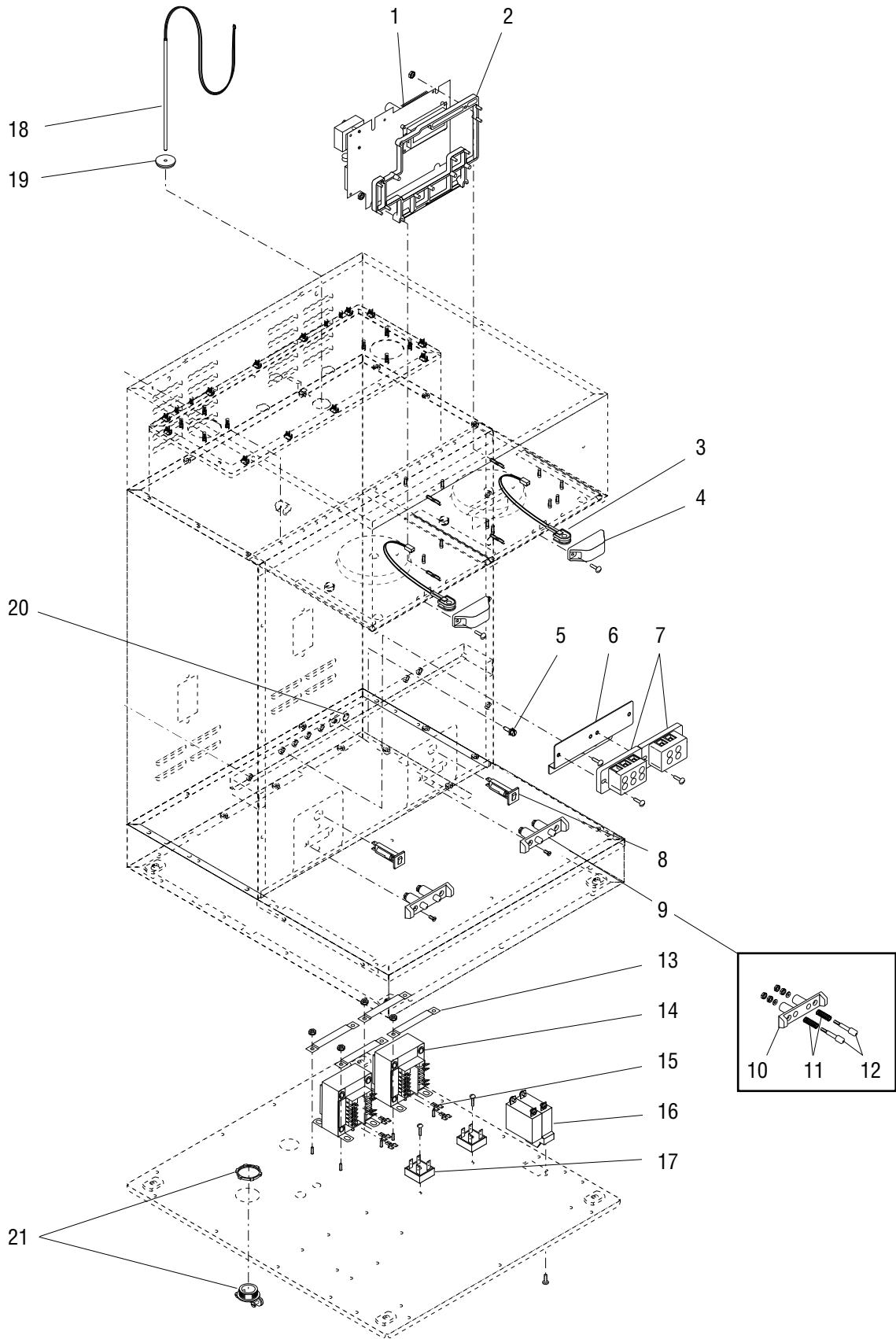

ELECTRICAL CONTROLS

ITEM	PART NO.	QTY.	DESCRIPTION
1	29969.1059	1	Circuit Board, Main control, 120/240V
	00973.0000	2	Nut, Keps #6-32
2	40726.0000	1	Mount, Circuit Board
	00973.0000	2	Nut, Keps #6-32
3	32572.1001	1	Sensing Coil, Brewer (Violet wires) (Includes plug below)
	32572.1002	1	Sensing Coil, Brewer (Yellow wires) (Includes plug below)
	20621.0000	2	Plug, hole .203" Dia. (Not illustrated)
4	32573.0000	2	Cover, Sensing Coil
	01382.0007	4	Screw, Truss Head #6-32 x .38"
5	01309.0000	1	Ground Screw W/Terminal Washer #10-32 x .50"
6	39248.0001	1	Bracket, Terminal Block Mounting
	02308.0000	2	Screw, Pan Head #8-32 x .38"
7	07038.0000	1	Terminal Block, 3 Pole (BLK/RED/WHI)
	01106.0001	1	Terminal Block, 2 Pole (BLK/RED)
	01317.0000	2	Screw, Truss Head #8-32 x .50"
8	27181.0001	2	Circuit Breaker, 4 amp
9	27790.1000	2	Receptacle Assy, Spring Contact (Includes items 10, 11 & 12)
	20608.0000	4	Screw, Flat Head #6-32 x .375" Black
	01345.0000	4	Screw, Flat Head #6-32 x .50" SST
10	27746.0000	1	Housing, Spring Contact
11	27788.0000	2	Spring
12	27748.0000	2	Pin, Contact
	01521.0000	2	Washer, Flat
	00973.0000	4	Nut, Keps #6-32 - Zinc Pl
13	28264.0000	4	Strap, Transformer Holddown (only 2 used on early models)
	01347.0000	4	Screw, Truss Head #6-32 x .375" (Early models)
	00970.0000	8	Nut, Keps #8-32 (Late models)
14	27253.0001	2	Transformer, 80VA (120/240V)
	01347.0000	4	Screw, Truss Head #6-32 x .375"
15	26722.0000	5	Adapter, Spade
16	38894.0001	1	Switch, Main Power (Not used on all models)
	01308.0002	2	Screw, Truss Head #6-32 x .25" (Switch Mounting)
	01327.0000	4	Screw, Pan Head #10-32 x .375"
	01512.0000	4	Lockwasher, External Tooth #10
17	22126.0000	2	Rectifier
	02367.0000	2	Screw, Truss Head #6-32 x .625"
18	29327.0000	1	Probe Kit, Temperature/Dry Plug
19	12570.0000	1	Grommet, Temperature Sensor
20	00824.0002	1	Decal, Ground
21	01590.0000	1	Connector, Cable 120/240V

(continued)

* Indicates the part number listed is for reference only. See DESCRIPTION for possible service replacement.

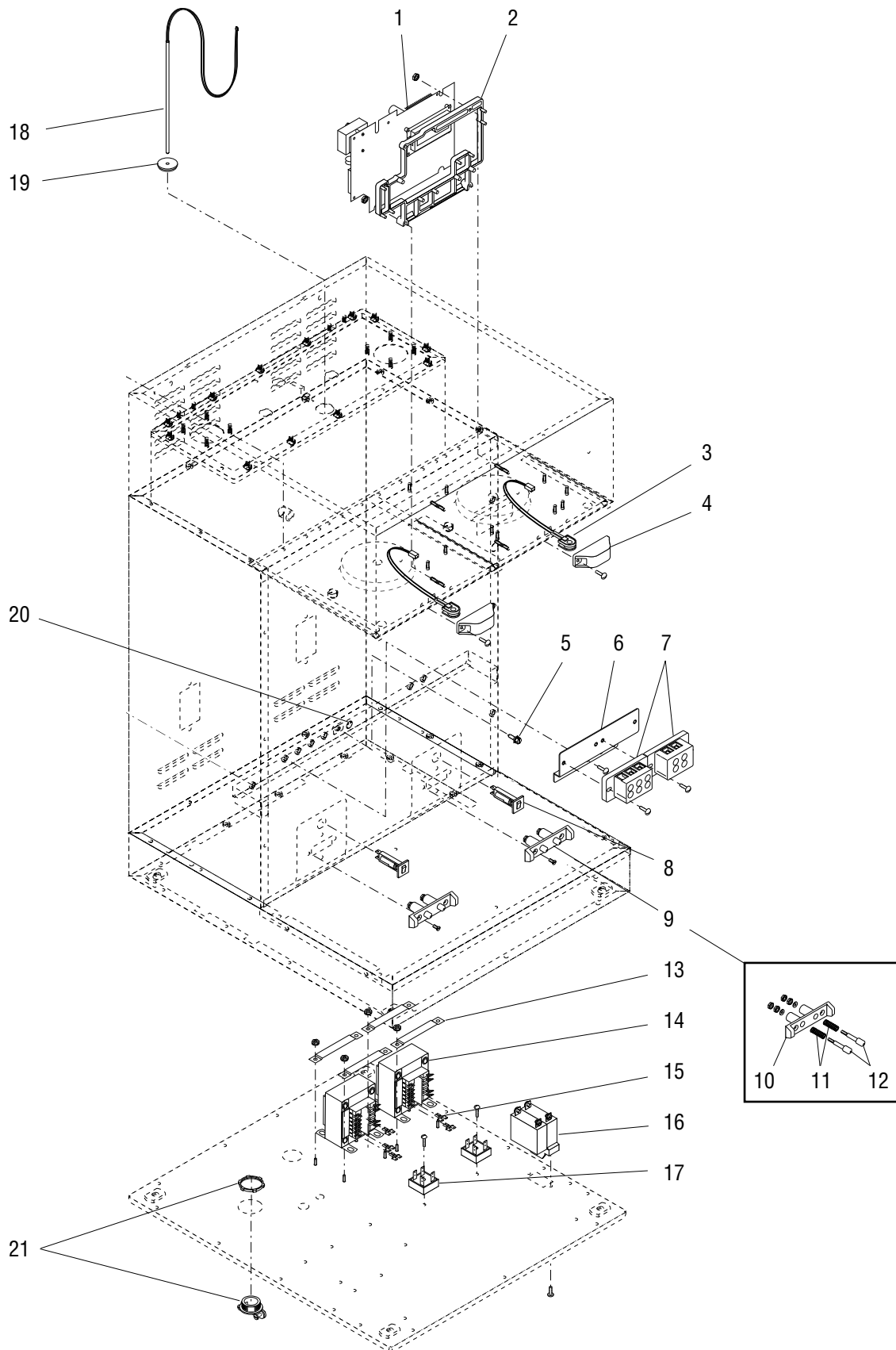

ELECTRICAL CONTROLS

ITEM	PART NO.	QTY.	DESCRIPTION
	Note: The following parts are not illustrated		
22	33634.0040	1	Wiring Harness, Main
23	27791.0001	1	Wiring Harness, Server Contacts (Left) 120/240V
	27791.0002	1	Wiring Harness, Server Contacts (Right) 120/240V
24	37859.0005	1	Wiring Harness, Main Power Switch
25	00603.0000	2	Clamp, Cable .438" I.D.
	02308.0000	2	Screw, Pan Head #8-32 x .38"
26	04831.0000	1	Clamp, Cable .188" I.D.

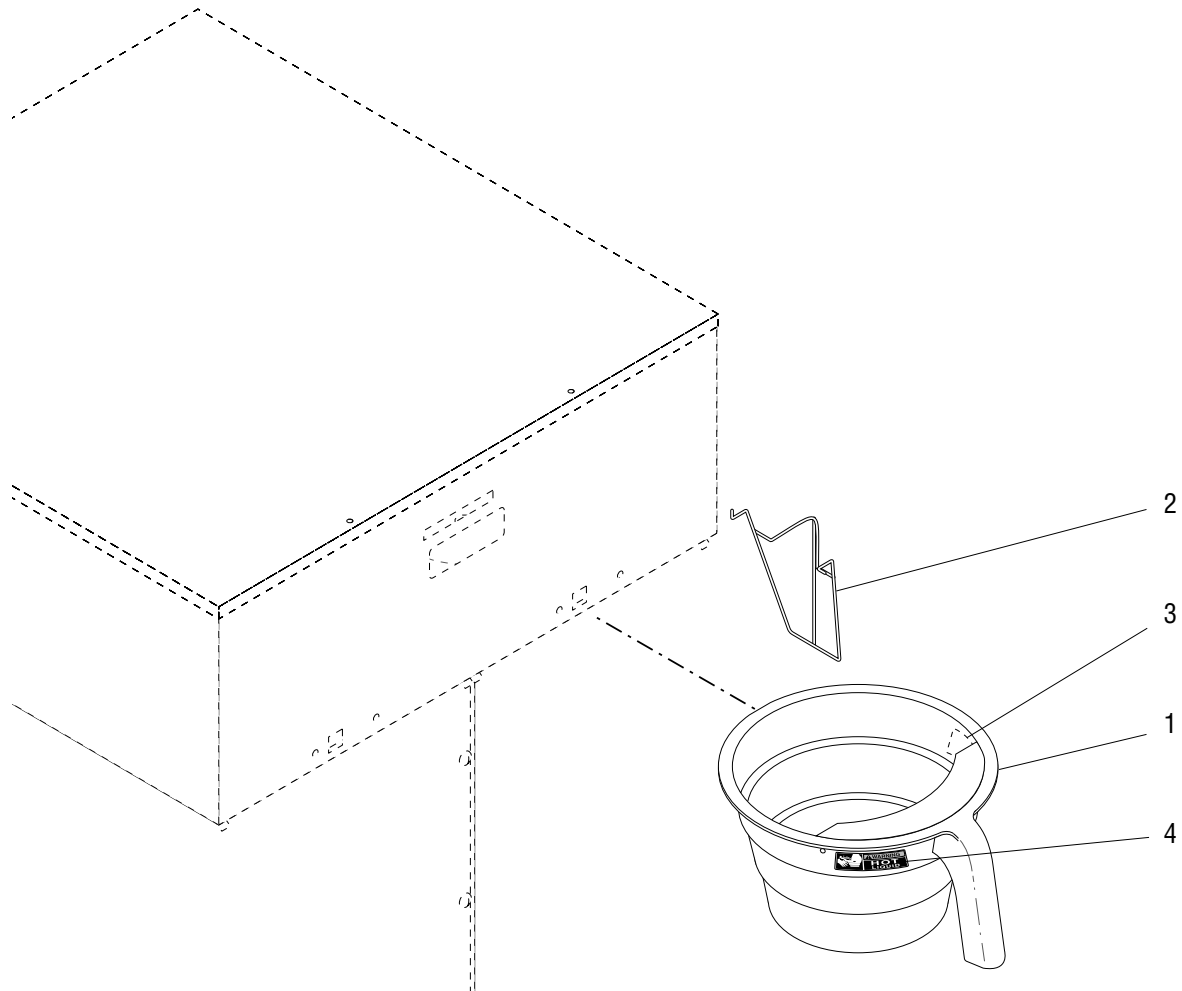

FUNNEL

ITEM	PART NO.	QTY.	DESCRIPTION
1	22735.0000	2	Funnel Assy, Black (Each includes Items 2 thru 4)
2	21911.0000	1	Funnel Adaptor, Water Bypass
3	03408.0004	1	Decal, Caution-Remove Funnel
4	03409.0004	1	Decal, Caution-Hot Liquid

NUMERICAL INDEX

PART NO.	PAGE NO.	PART NO.	PAGE NO.	PART NO.	PAGE NO.	PART NO.	PAGE NO.
00400.0001.....	11	03236.1001.....	7	25376.0002.....	5	41266.0000.....	7
00402.0001.....	11	03236.1002.....	7	26528.0000.....	5	41280.0001.....	7
00459.0000.....	11	03236.1003.....	7	26622.0001.....	7	M2517.0000.....	17
00463.0000.....	11	03408.0004.....	23	26722.0000.....	19	M2522.1000.....	7
00603.0000.....	21	03633.0000.....	7	26846.0000.....	15		
00619.0005.....	5	03803.0000.....	7	26949.0001.....	5		
00620.0000.....	11	03807.0000.....	7	27181.0001.....	19		
00656.0001.....	5	03851.0000.....	7	27253.0001.....	19		
00658.0000.....	5	03996.0000.....	5	27370.0000.....	13		
00824.0002.....	19	04797.0000.....	7	27473.0000.....	7		
00908.0000.....	7,9	04831.0000.....	21	27746.0000.....	19		
00916.0000.....	5	05749.0004.....	5	27748.0000.....	19		
00946.0000.....	7	07038.0000.....	19	27760.0002.....	5		
00950.0000.....	11	11517.0008.....	15	27788.0000.....	19		
00970.0000.....	5,13,19	11630.0001.....	9	27790.1000.....	19		
00971.0000.....	7,9	12249.0001.....	5	27791.0001.....	21		
00973.0000.....	19	12398.0002.....	7	27791.0002.....	21		
00986.0000.....	5	12422.0000.....	7	28264.0000.....	19		
01075.0000.....	15	12422.0001.....	13,17	28706.0002.....	17		
01079.0000.....	11	12422.0005.....	13	29075.0000.....	17		
01085.0006.....	11	12422.0008.....	15	29264.0000.....	17		
01101.0000.....	11	12422.0009.....	9,13	29327.0000.....	19		
01106.0001.....	19	12565.0028.....	7	29421.0000.....	9		
01111.0000.....	11	12570.0000.....	19	29876.0015.....	5		
01116.0000.....	11	13054.0000.....	17	29969.1059.....	19		
01308.0002.....	19	20201.4301.....	11	29974.0007.....	5		
01309.0000.....	19	20201.5600.....	5	32572.1001.....	19		
01317.0000.....	19	20203.0100.....	7	32572.1002.....	19		
01327.0000.....	11,19	20541.0001.....	7	32573.0000.....	19		
01345.0000.....	19	20608.0000.....	19	32591.0007.....	13		
01347.0000.....	5,19	20621.0000.....	19	32591.0009.....	13		
01382.0003.....	5	20878.1008.....	9	32591.0011.....	9		
01382.0007.....	7,19	20881.0001.....	9	32591.1000.....	13		
01501.0000.....	7	20883.0000.....	9	32591.1002.....	9		
01502.0000.....	11	20922.1000.....	7	32648.0000.....	13		
01512.0000.....	19	20936.1000.....	7	32649.0000.....	5		
01520.0000.....	7	20937.0000.....	11	33634.0040.....	21		
01521.0000.....	19	20976.0003.....	13	33871.0000.....	5		
01532.0000.....	11	20976.0006.....	13	34956.0011.....	15		
01532.0005.....	17	20976.0036.....	17	35052.0001.....	15		
01590.0000.....	19	20976.1000.....	13,15,17	35052.1000.....	15		
02308.0000.....	5,9,11,19,21	20976.1001.....	13,15,17	35086.0000.....	9		
02328.0003.....	7	20976.1002.....	13,15,17	35158.1000.....	5		
02336.0002.....	5	20977.1000.....	11	35160.1000.....	5		
02367.0000.....	19	21537.0001.....	5	35162.0000.....	9		
02434.0010.....	7	21801.0002.....	7	35334.0000.....	5		
02434.1000.....	7	21911.0000.....	23	35388.0006.....	5		
02536.0000.....	7,11	22126.0000.....	21	37526.0000.....	9		
02594.0000.....	17	22305.0000.....	15	37859.0005.....	21		
02595.0000.....	17	22735.0000.....	23	38894.0001.....	19		
02766.0000.....	17	23254.0000.....	15	38936.0007.....	5		
02854.0000.....	17	23255.0000.....	15	39248.0000.....	19		
02856.0002.....	17	23256.0000.....	15	39803.0000.....	5		
02858.0000.....	17	23717.0003.....	7	40670.0012.....	15		
02861.0000.....	17	25134.0001.....	11	40726.0000.....	19		
03236.0007.....	7	25151.0000.....	5	41259.1003.....	7		