

---

# BUNN®

## *G9 HD* *G9T HD*

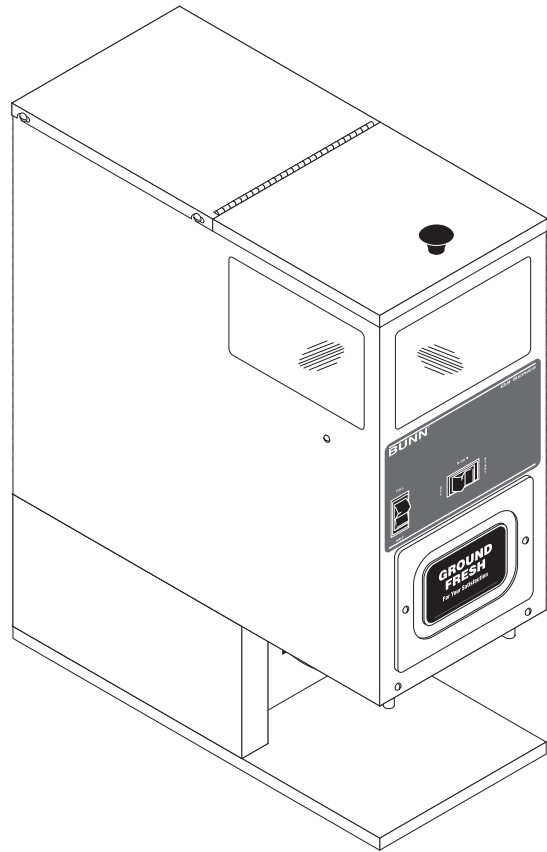
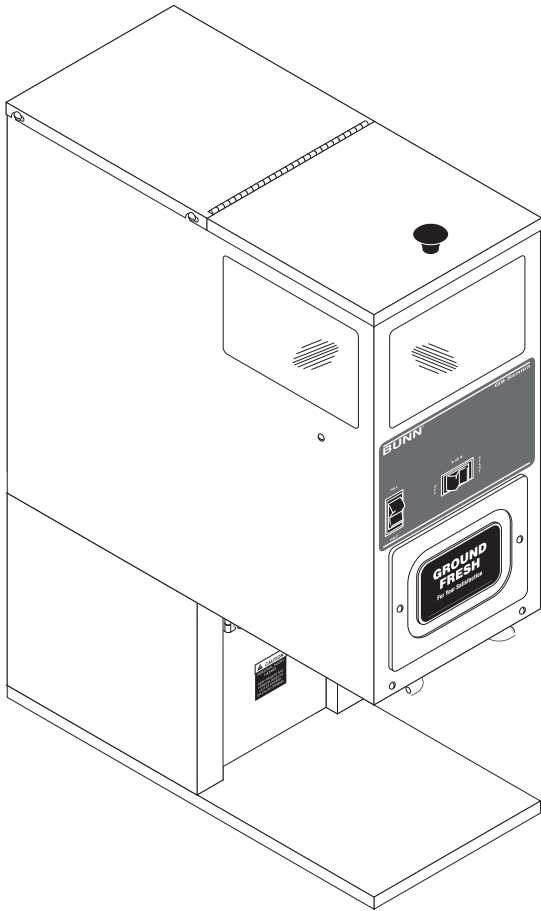

## ILLUSTRATED PARTS CATALOG

Designs, materials, weights, specifications, and dimensions for equipment or replacement parts are subject to change without notice.

**BUNN-O-MATIC CORPORATION**

POST OFFICE BOX 3227

SPRINGFIELD, ILLINOIS 62708-3227

PHONE: (217) 529-6601 FAX: (217) 529-6644



## **BUNN-O-MATIC COMMERCIAL PRODUCT WARRANTY**

Bunn-O-Matic Corp. ("BUNN") warrants equipment manufactured by it as follows:

- 1) Airpots, thermal carafes, decanters, GPR servers, iced tea/coffee dispensers, MCP/MCA pod brewers thermal servers and Thermofresh servers (mechanical and digital)- 1 year parts and 1 year labor.
- 2) All other equipment - 2 years parts and 1 year labor plus added warranties as specified below:
  - a) Electronic circuit and/or control boards - parts and labor for 3 years.
  - b) Compressors on refrigeration equipment - 5 years parts and 1 year labor.
  - c) Grinding burrs on coffee grinding equipment to grind coffee to meet original factory screen sieve analysis - parts and labor for 4 years or 40,000 pounds of coffee, whichever comes first.

These warranty periods run from the date of installation BUNN warrants that the equipment manufactured by it will be commercially free of defects in material and workmanship existing at the time of manufacture and appearing within the applicable warranty period. This warranty does not apply to any equipment, component or part that was not manufactured by BUNN or that, in BUNN's judgment, has been affected by misuse, neglect, alteration, improper installation or operation, improper maintenance or repair, non periodic cleaning and descaling, equipment failures related to poor water quality, damage or casualty. In addition, the warranty does not apply to replacement of items subject to normal use including but not limited to user replaceable parts such as seals and gaskets. This warranty is conditioned on the Buyer 1) giving BUNN prompt notice of any claim to be made under this warranty by telephone at (217) 529-6601 or by writing to Post Office Box 3227, Springfield, Illinois 62708-3227; 2) if requested by BUNN, shipping the defective equipment prepaid to an authorized BUNN service location; and 3) receiving prior authorization from BUNN that the defective equipment is under warranty.

**THE FOREGOING WARRANTY IS EXCLUSIVE AND IS IN LIEU OF ANY OTHER WARRANTY, WRITTEN OR ORAL, EXPRESS OR IMPLIED, INCLUDING, BUT NOT LIMITED TO, ANY IMPLIED WARRANTY OF EITHER MERCHANTABILITY OR FITNESS FOR A PARTICULAR PURPOSE.** The agents, dealers or employees of BUNN are not authorized to make modifications to this warranty or to make additional warranties that are binding on BUNN. Accordingly, statements by such individuals, whether oral or written, do not constitute warranties and should not be relied upon.

If BUNN determines in its sole discretion that the equipment does not conform to the warranty, BUNN, at its exclusive option while the equipment is under warranty, shall either 1) provide at no charge replacement parts and/or labor (during the applicable parts and labor warranty periods specified above) to repair the defective components, provided that this repair is done by a BUNN Authorized Service Representative; or 2) shall replace the equipment or refund the purchase price for the equipment.

**THE BUYER'S REMEDY AGAINST BUNN FOR THE BREACH OF ANY OBLIGATION ARISING OUT OF THE SALE OF THIS EQUIPMENT, WHETHER DERIVED FROM WARRANTY OR OTHERWISE, SHALL BE LIMITED, AT BUNN'S SOLE OPTION AS SPECIFIED HEREIN, TO REPAIR, REPLACEMENT OR REFUND.**

In no event shall BUNN be liable for any other damage or loss, including, but not limited to, lost profits, lost sales, loss of use of equipment, claims of Buyer's customers, cost of capital, cost of down time, cost of substitute equipment, facilities or services, or any other special, incidental or consequential damages.

392, AutoPOD, AXIOM, BrewLOGIC, BrewMETER, Brew Better Not Bitter, BrewWISE, BrewWIZARD, BUNN Espresso, BUNN Family Gourmet, BUNN Gourmet, BUNN Pour-O-Matic, BUNN, BUNN with the stylized red line, BUNNlink, Bunn-O-Matic, Bunn-O-Matic, BUNNserve, BUNNSERVE with the stylized wrench design, Cool Froth, DBC, Dr. Brew stylized Dr. design, Dual, Easy Pour, EasyClear, EasyGard, FlavorGard, Gourmet Ice, Gourmet Juice, High Intensity, iMIX, Infusion Series, Intellisteam, My Café, Phase Brew, PowerLogic, Quality Beverage Equipment Worldwide, Respect Earth, Respect Earth with the stylized leaf and coffee cherry design, Safety-Fresh, savemycoffee.com, Scale-Pro, Silver Series, Single, Smart Funnel, Smart Hopper, SmartWAVE, Soft Heat, SplashGard, The Mark of Quality in Beverage Equipment Worldwide, ThermoFresh, Titan, trifacta, Velocity Brew, A Partner You Can Count On, Air Brew, Air Infusion, Beverage Bar Creator, Beverage Profit Calculator, Brew better, not bitter., BUNNSource, Coffee At Its Best, Cyclonic Heating System, Daypart, Digital Brewer Control, Nothing Brews Like a BUNN, Pouring Profits, Signature Series, Tea At Its Best, The Horizontal Red Line, Ultra are either trademarks or registered trademarks of Bunn-O-Matic Corporation.

# TABLE OF CONTENTS

TITLE	PAGE NO.
Electrical Controls .....	12
Hopper & Lid Assy .....	8
Housing, Base and Panels .....	4
Motor, Burr Housing and Mounting Plate.....	10
Numerical Index.....	16

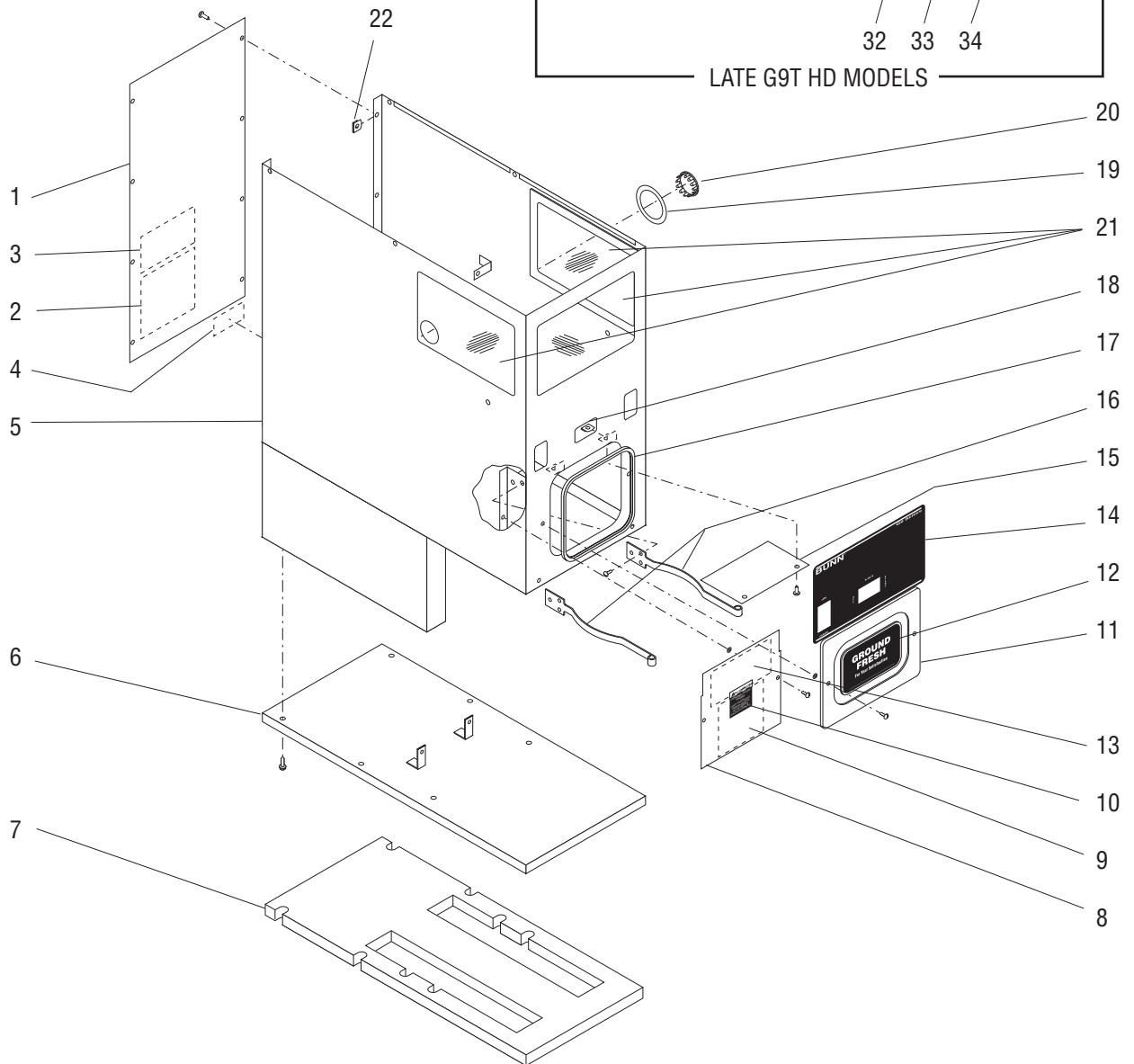
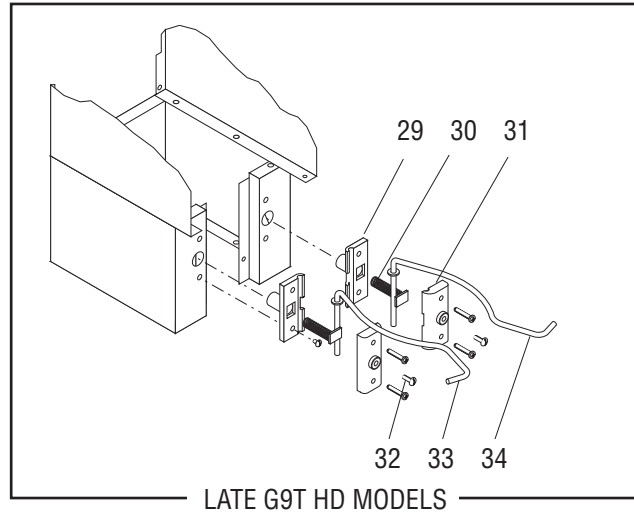
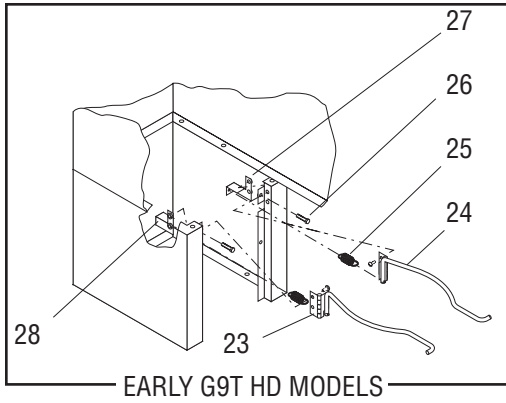

## HOUSING, BASE AND PANELS

ITEM	PART NO.	QTY.	DESCRIPTION	
1	05844.1000	1	Rear Panel W/Decal (Includes items 2 & 3)	
	01315.0000	8	Screw, Truss Head #8 - 32 x .38"	
	02322.0002	8	Screw, Truss Head (BLK) #8 - 32 x .38"	
2	20545.0000	1	Decal, Warning Electrical	
3	37881.0000	1	Decal, No Serviceable Parts	
4	24237.0000	1	Decal, Notice - Interface Voltage	
5	25407.0000	1	Housing Assy W/Decals (G9 HD 120V)	Includes items 3, 18, 19 & 3 of item 21. Also order item 14
	25407.0001*	1	Housing Assy W/Decals (G9 HD 240V)	
	25408.0000	1	Housing Assy W/Decals (G9T HD 120V)	
	25408.0001*	1	Housing Assy W/Decals (G9T HD 240V)	
	25407.0005	1	Housing Assy W/Decals (BLK)(G9 HD 120V)	
6	05809.0000	1	Base (G9 HD) (Shown)	
	05809.0002	1	Base (G9 HD)(BLK) (Shown)	
	05752.0000	1	Base (G9T HD)	
	02311.0000	6	Screw, Hex Crimptite 10 - 32 x .50"	
7	05816.0000	1	Pad, Base	
8	21619.1000	1	Panel Assy W/Decals (120V) (G9 HD)	Includes screws and washers below and items 9 & 10
	21619.1008	1	Panel Assy W/Decals (BLK)(120V) (G9 HD)	
	21619.1003	1	Panel Assy W/Decals (120V) (G9T HD)	
	21619.1009	1	Panel Assy W/Decals (BLK)(120V) (G9T HD)	Includes screws and washers below and item 10
	21619.1002	1	Panel Assy W/Decals (240V) (G9 HD)	
	21619.1005	1	Panel Assy W/Decals (240V) (G9T HD)	
	01380.0000	2	Screw, Truss Head #6 - 32 x .50"	
	01382.0002	2	Screw, Truss Head (BLK) #6 - 32 x .50"	
01518.0000	2	Washer, Screw Retaining #6		
9	10173.0000	1	Schematic 120V	
10	05876.0000	1	Decal, Caution	
11	21620.1000	1	Cover Assy W/Decal (Includes screws and washers below and item 11 & 12)	
	21620.1011	1	Cover Assy W/Decal (BLK) (Includes screws and washers below and item 11 & 12)	
	01380.0000	2	Screw, Truss Head #6 - 32 x .50"	
	01518.0000	2	Washer, Screw Retaining #6	
	01382.0002	2	Screw, Truss Head (BLK) #6 - 32 x .50"	
12	33735.0002	1	Decal, Ground Fresh	
13	10239.0000	1	Label, Timer Setting	
14	24239.0002	1	Decal, Control Panel (Grinders with Single Set)	
	24239.0003	1	Decal, Control Panel (Grinders with Multi Set Option) (Shown)	
	24239.0004	1	Decal, Control Panel (Grinders with Half Batch Option)	
15	05827.0000	1	Plate, Switch Shield	
	02308.0000	2	Screw, Pan Head #8 - 32 x .38"	
16	05839.0000	2	Funnel Rail	
	02308.0000	4	Screw, Pan Head #8 - 32 x .38"	

(Continued)

(Continued)

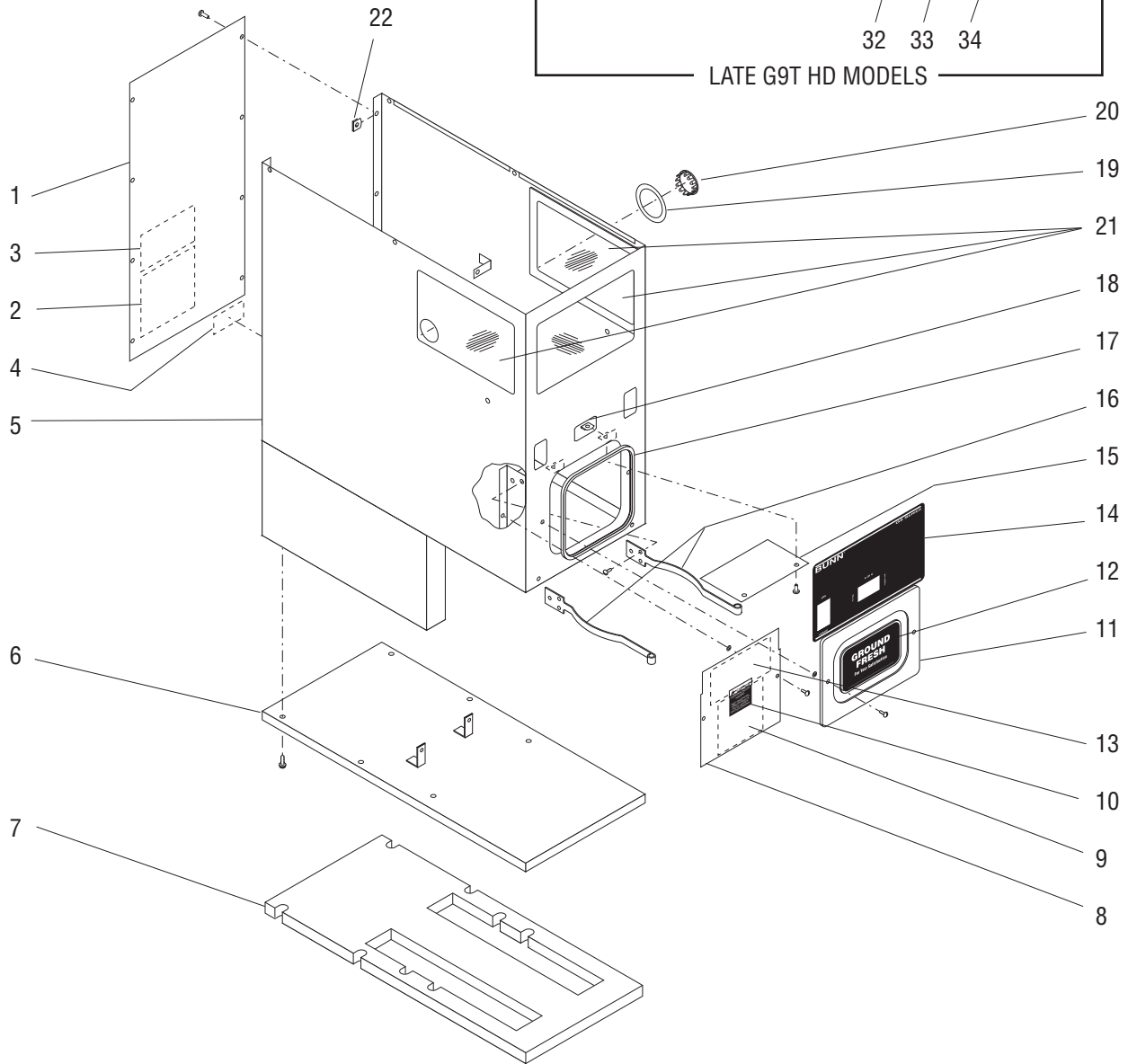
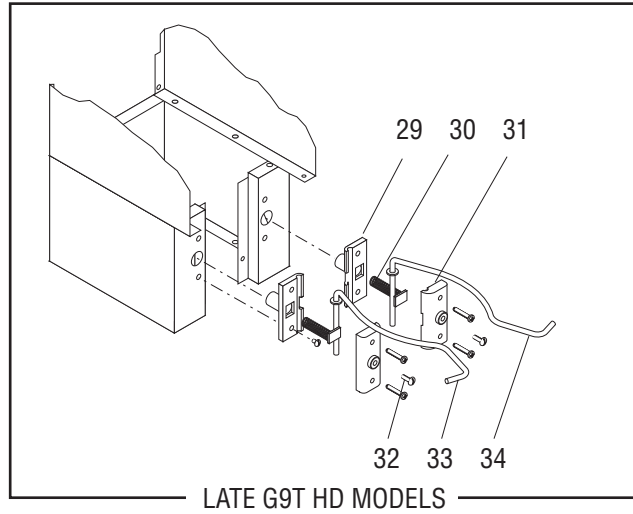
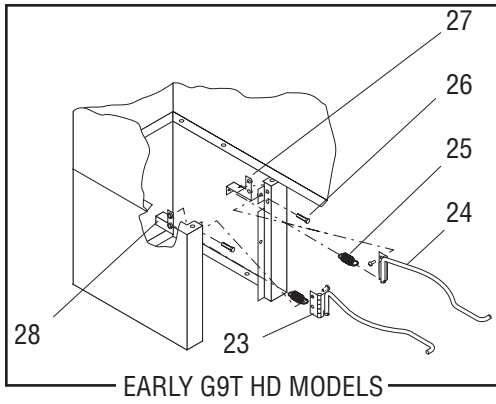

## HOUSING, BASE AND PANELS

ITEM	PART NO.	QTY.	DESCRIPTION		
17	-----	1	Edging 19.15" (Order item 35)		
18	00912.0000	2	Clip, J-Type #8 - 32		
19	05884.0000	1	Decal, Motor Reset		
20	02999.0000	1	Plug, Hole 1.19" Dia.		
	25126.0000	1	Plug, Hole (BLK) 1.19" Dia.		
21	05814.0001	3	Window Assy (Includes adhesive)		
22	00917.0000	8	Clip, J-Type #8 - 32		
23	05771.0000	1	Funnel Rail, Left	} Early Model G9T HD only	
	02308.0000	2	Screw, Pan Head #8 - 32 x .38"		
24	05770.0000	1	Funnel Rail, Right		
	02308.0000	2	Screw, Pan Head #8 - 32 x .38"		
25	05781.0000	2	Spring		
26	05743.0000	2	Screw, Stop #8 - 32 x .75"		
27	05742.0000	1	Bracket, Right Spring		
28	05741.0000	1	Bracket, Left Spring		
29	32561.0000	2	Bracket, Inner Spring		} Late Model G9T HD only
30	32570.0000	2	Spring		
31	39586.1000	2	Bracket, Outer Spring		
	01326.0008	4	Screw, Truss Head BLK #10-32 x 1.25"		
32	01317.0000	2	Screw, Adjustment, Truss Head BLK #8-32 x .50"		
33	32568.0001	1	Funnel Rail, Left		
34	32569.0001	1	Funnel Rail, Right		
35	38278.1002	-	Edging 36.0" (Cut to required length)		

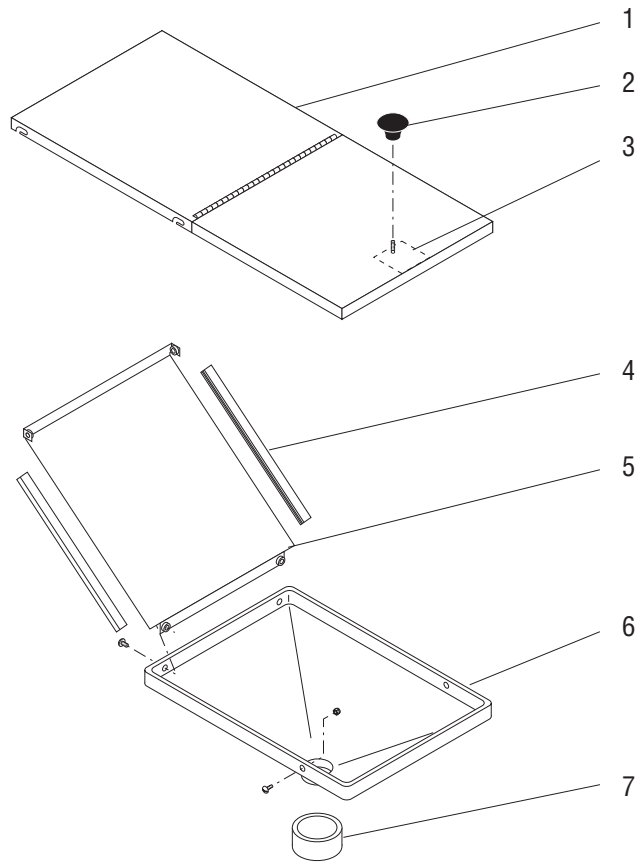
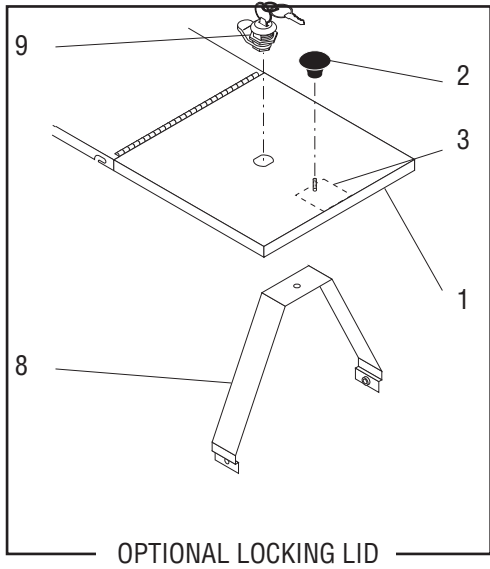



## HOPPER AND LID ASSEMBLY

ITEM	PART NO.	QTY.	DESCRIPTION
1	21622.1000	1	Lid Assy, Hopper
	21622.1002	1	Lid Assy, Hopper (BLK)
	-----	1	Lid Assy, Hopper Locking
	01347.0000	4	Screw, Pan Head #6 - 32 x .375"
			} Includes items 2 & 3
2	00725.0000	1	Knob
3	05876.0000	1	Decal, Caution
4	-----	2	Gasket, U-Channel 8.4" (Order item 10)
5	05828.0000	1	Hopper Extension
	01347.0000	2	Screw, Pan Head #6 - 32 x .38"
	01382.0002	2	Screw, Pan Head (BLK) #6 - 32 x .38"
	00991.0002	2	Nut, Elastic Lock #6-32
6	05871.0001	1	Hopper
	01311.0001	2	Screw, Truss Head, Locking #8 - 32 x .25"
	01311.0003	2	Screw, Pan Head (BLK) #8 - 32 x .25"
	01338.0000	2	Screw, Truss Head #8 - 32 x .625" (Locking Lid)
	00991.0000	2	Nut, Elastic Lock #8 - 32
7	05872.0000	1	Sleeve, Hopper
8	-----	1	Bracket, Lid Locking (Early Models)
9	11628.0000	1	Lid Lock Assy (Includes Keys) (New Keys should be made locally)
10	02434.1000	-	Gasket, U-Channel 18.0" (Not illustrated)

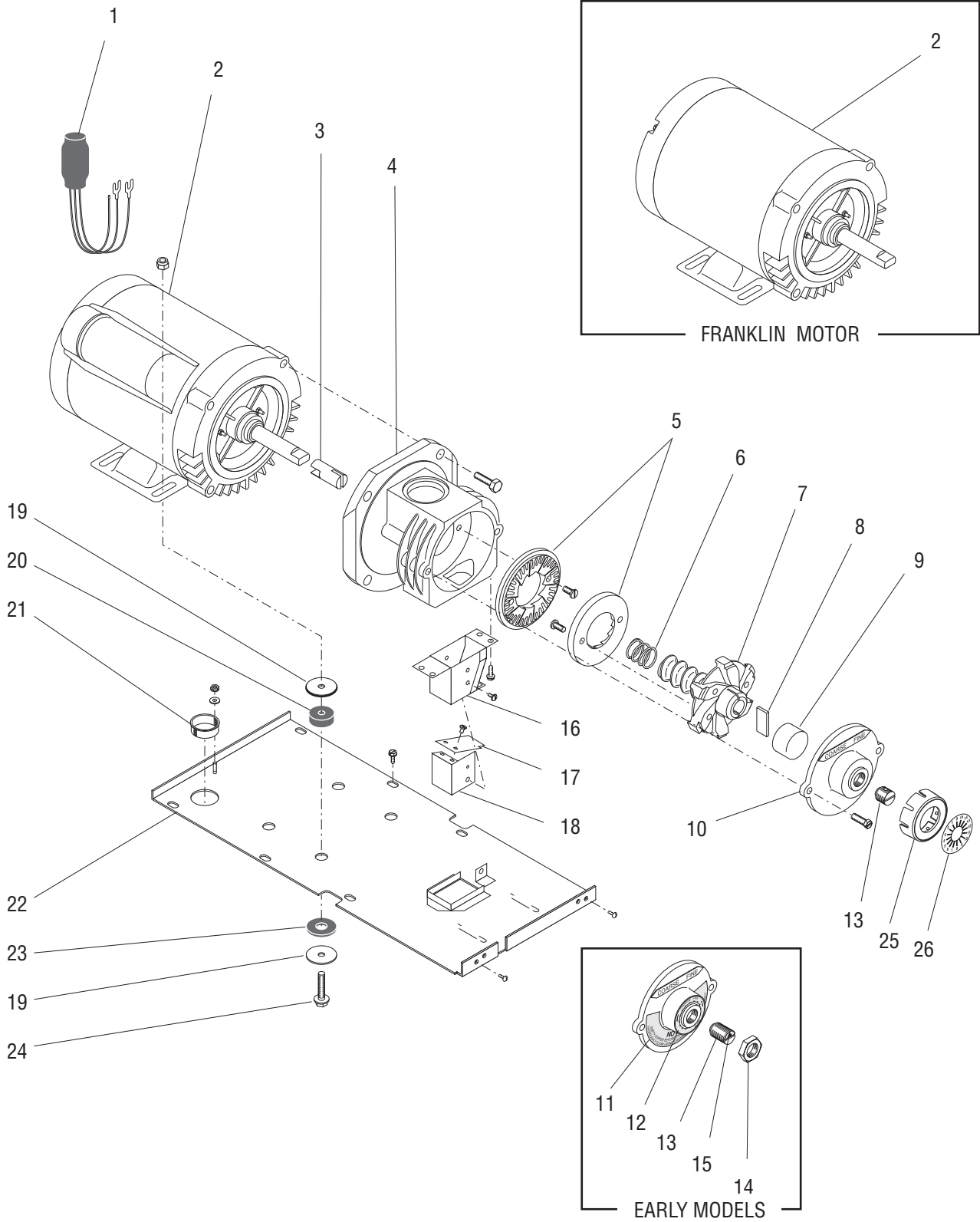

## MOTOR, BURR HOUSING AND MOUNTING PLATE

ITEM	PART NO.	QTY.	DESCRIPTION
1	05965.0000	1	Snubber Assy, Timer (Early Models)
2	-----	1	Motor Assy, 115V (Franklin)(Early models. Order late model Motor)
	11029.1005	1	Motor Assy, 115V (Marathon)(Late models)
	11029.1006	1	Motor Assy, 240V
3	11191.0001	1	Shaft Extension
4	11180.0000	1	Burr Housing
	02313.0000	4	Screw, Hex Head .38" - 16 x 1.0"
5	05861.1002	1	Burr Set (Includes 2 Burrs and Screws below)
	02314.0000	4	Screw, Pan Head .25" - 20 x .50"
6	11192.0000	1	Spring
7	11185.0001	1	Burr Auger Rotor/Spring Assy (Includes item 6)
8	05852.0001	1	Shear Plate
9	00622.0000	1	Cup, Burr Rotor
10	05867.0000	1	Cap W/Decals, Burr Housing (Includes items 11 & 12)
	05867.0002	1	Cap & Adjustng Screw W/Decals, Burr Housing (Includes items 11 thru14) (Also order item 15)
	20631.0000	2	Screw, Slotted Hex Head .25" - 20 x .75"
11	05868.0000	1	Decal, Housing Cover
12	05880.0000	1	Decal, Grind Indicator
13	35184.0000	1	Adjusting Screw (Also order item 15)
14	00989.0000	1	Nut, Locking
15	05796.0000	1	Decal, Adjusting Screw
16	05951.0000	1	Chute
	02330.0001	4	Screw, Slotted Hex Head #10 - 24 x .38"
17	05995.0000	1	Dechaffer Plate
	02327.0002	2	Screw, Pan Head #4 - 40 x .312"
18	05954.0000	1	Dechaffer Assy (Includes item 17)
	02328.0002	1	Screw, Pan Head #6 - 32 x .188"
19	01539.0000	8	Washer, Flat
20	05881.0000	4	Bushing
21	00718.0000	1	Bushing, 1.125" Dia. Hole
22	29883.0001	1	Plate, Motor Mounting (G9)
	29883.0002	1	Plate, Motor Mounting (G9T)
	01330.0000	6	Screw, Slotted Hex Head #10 - 32 x .50"
	01347.0000	2	Screw, Truss Head SST #6 - 32 x .38"
23	05882.0000	4	Washer, 1.50" Dia.
24	02312.0000	4	Screw, Hex Washer Head .312" - 18 X 1.50"
	00987.0000	4	Nut, Lock .312" - 18
25	34107.0000	1	Cap, Indicator Adjustment
26	34213.0000	1	Decal, Burr Adjustment
27	21621.1011	-	Motor & Plate Assy (120V G9 only)(Includes items 2, 11 & 15-24)

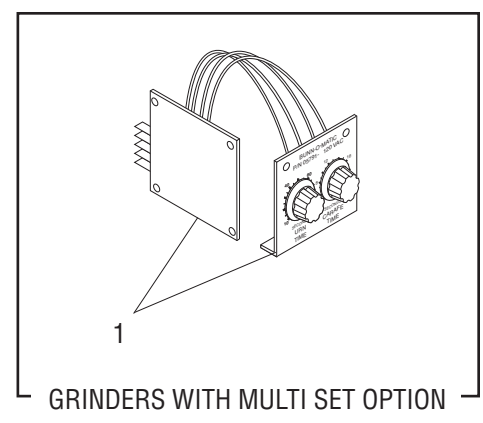
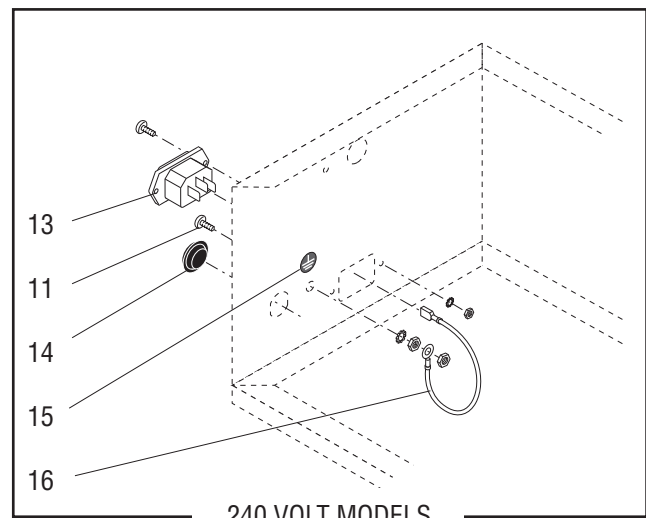
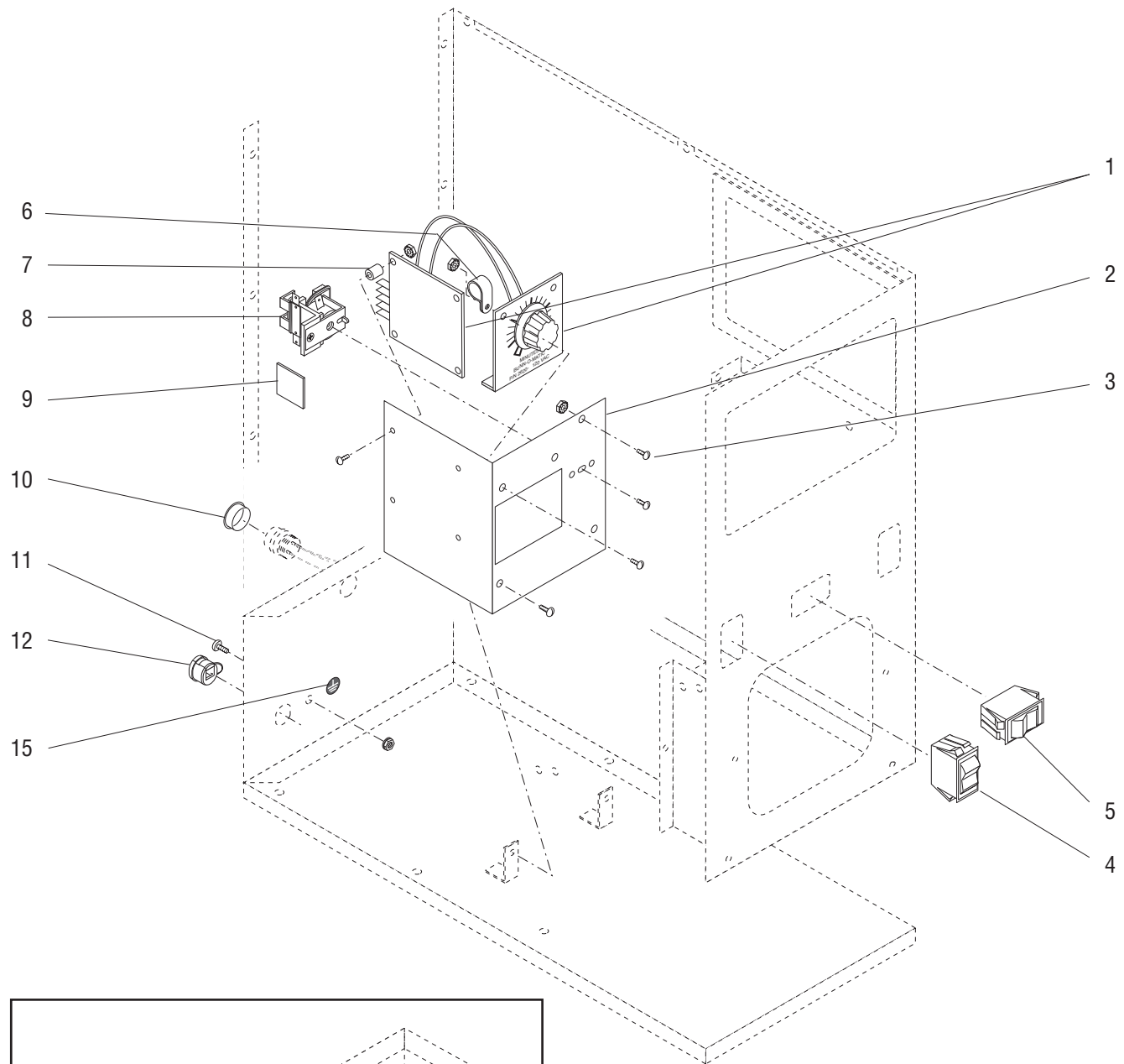

## ELECTRICAL CONTROLS

ITEM	PART NO.	QTY.	DESCRIPTION		
1	02620.1046	1	Timer Assy (100/120V)		
	02620.1034	1	Timer Assy (240V)		
	02620.1049	1	Timer Assy (240V)(RoHS Compliant)		
	02620.1036	1	Timer Assy (120V) (Grinders with Half/Full Batch Option & RT/OT Interface Option)		
	41790.1000	1	Timer Assy (120V) (Grinders with System III & Dual Interface Option)		
	05791.1001	1	Timer Assy (120V) (Grinders with Multi Set Option)		
	02308.0000	2	Screw, Pan Head #8 - 32 x .375"	} Grinders without Multi Set Option	
	00970.0000	2	Nut, Keps #8 - 32		
	01388.0000	4	Screw, Truss Head #6 - 32 x .75"		
	00973.0000	4	Nut #6 - 32		
		01347.0000	2	Screw, Truss Head #6 - 32 x .375"	} Grinders with Multi Set Option
		01388.0000	4	Screw, Truss Head #6 - 32 x .75"	
		00973.0000	6	Nut #6 - 32	
2		41947.0000	1	Bracket, Timer	
		01315.0000	2	Screw, Truss Head #8 - 32 x .375"	
		01516.0000	2	Washer, Nylon	
3	02308.0000	1	Screw, Pan Head #8 - 32 x .375" (Ground)	} Grinders without Multi Set Option	
	00970.0000	1	Nut, Keps #8 - 32		
	01347.0000	1	Screw, Truss Head #6 -32 x .375" (Ground)	} Grinders with Multi Set Option	
	00973.0000	1	Nut, Keps #6 - 32		
4	05789.0000	1	Switch, Rocker (Grinders with Multi Set Option)		
	06536.0000	1	Switch, Rocker (Grinders with Half/Full Batch Option)		
5	05815.0000	1	Switch, Off/On/Start		
6	04831.0000	1	Clamp, Cable		
7	01533.0000	4	Spacer, Timer Board		
8	37711.1002	1	Relay (120V)		
	05892.0000	1	Relay (240V)		
	05893.0000	1	Relay (100V)		
	01347.0000	1	Screw, Truss Head #6 - 32 x .375"		
9	22749.0000	2	Pad, Mounting Cable Tie	} Early Models	
	00617.0000	2	Tie, Cable Nylon (Not illustrated)		
10	27657.0000	1	Cap, Dust		
11	01326.0000	1	Screw, Ground Truss Head SST #10 - 32 x .25"		
	00991.0003	1	Nut, Elastic Lock #10 - 32		
12	01686.0000	1	Bushing, Strain Relief (120V)		
13	01908.0000	1	Power Connector (240V)	} 240 Volt Grinders only	
	01362.0000	2	Screw, Oval Head #4 - 40 x .50"		
	01509.0000	2	Lockwasher, External Tooth #4		
	00937.0000	2	Nut, Hex #4 - 40		
14	05749.0001	1	Plug .625" Dia.		
15	00824.0002	1	Decal, Ground		
16	-----	1	Lead, Elec. Grn/Yel 4.0" (Ground)		
	01512.0000	1	Lockwasher, External Tooth #10		

(Continued)

(Continued)

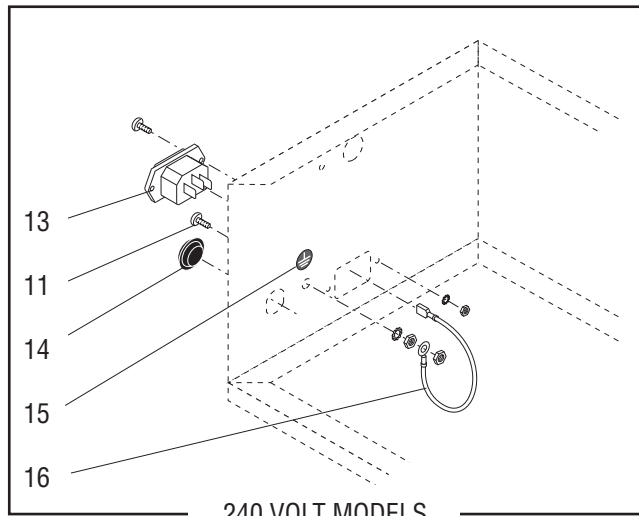
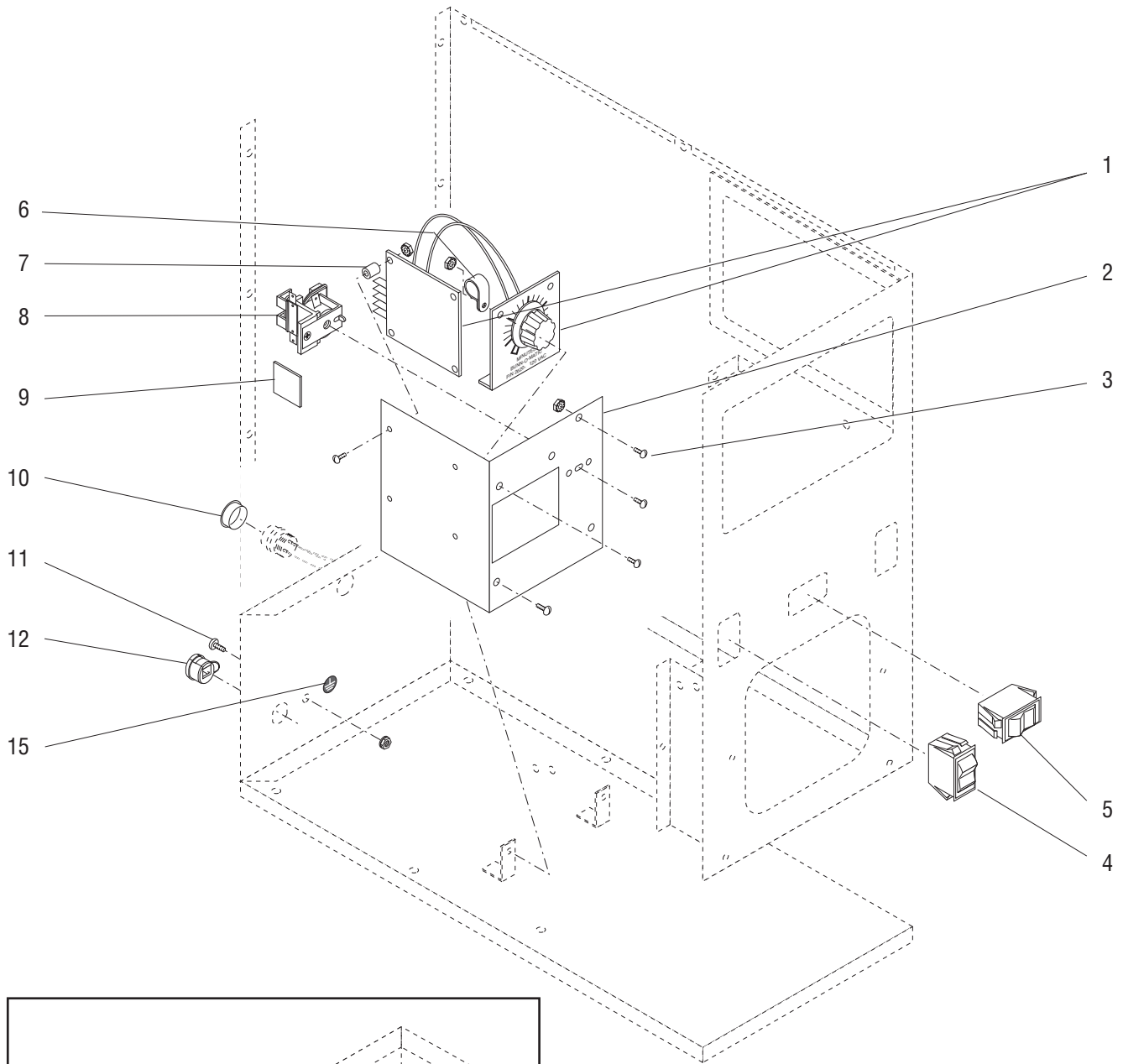

240 VOLT MODELS

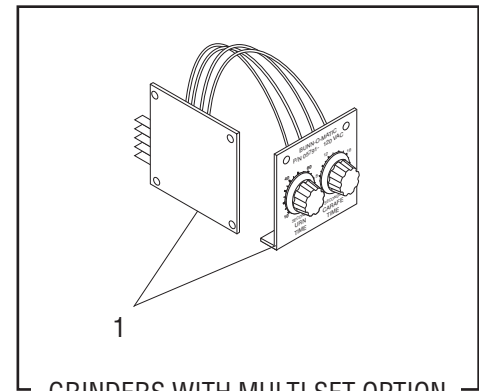

GRINDERS WITH MULTI SET OPTION

## ELECTRICAL CONTROLS

ITEM	PART NO.	QTY.	DESCRIPTION
	NOTE: The following items are not illustrated		
17	05887.0000	1	Wiring Harness, Main (120V)
	05887.0001	1	Wiring Harness, Main (240V)
18	05904.0001	1	Wiring Harness, Switch/Timer (Grinders with Multi Set Option)
19	05778.0000	1	Wiring Harness, Interface (System III Interface Option)
	05778.0001	1	Wiring Harness, Interface (Dual Interface Option)
	05185.0000	1	Wiring Harness, Interface (RT/OT Interface Option)
20	05188.0002	1	Cable, Interface
21	40699.0004	1	Cord Assy, Power 120V
22	00669.0000	1	Plug .625" Dia. (Grinders W/O Interface)

## NUMERICAL INDEX

PART NO.	PAGE NO.	PART NO.	PAGE NO.	PART NO.	PAGE NO.	PART NO.	PAGE NO.
00617.0000	13	05742.0000	7	21619.1003	5		
00622.0000	11	05743.0000	7	21619.1005	5		
00669.0000	15	05749.0001	13	21619.1008	5		
00718.0000	11	05752.0000	5	21619.1009	5		
00725.0000	9	05770.0000	7	21620.1000	5		
00824.0002	13	05771.0000	7	21620.1011	5		
00912.0000	7	05778.0000	15	21621.1011	11		
00917.0000	7	05778.0001	15	21622.1000	9		
00937.0000	13	05781.0000	7	21622.1002	9		
00970.0000	13	05789.0000	13	22749.0000	13		
00973.0000	13	05791.1001	13	24237.0000	5		
00987.0000	11	05796.0000	11	24239.0002	5		
00989.0000	11	05809.0000	5	24239.0003	5		
00991.0000	9	05809.0002	5	24239.0004	5		
00991.0002	9	05814.0001	7	25126.0000	7		
00991.0003	13	05815.0000	13	25407.0000	5		
01311.0001	9	05816.0000	5	25407.0001	5		
01311.0003	9	05827.0000	5	25407.0005	5		
01315.0000	5,13	05828.0000	9	25408.0000	5		
01317.0000	7	05839.0000	5	25408.0001	5		
01326.0000	13	05844.1000	5	27657.0000	13		
01326.0008	7	05852.0001	11	29883.0001	11		
01330.0000	11	05861.1002	11	29883.0002	11		
01338.0000	9	05867.0000	11	32561.0000	7		
01347.0000	9,11,13	05867.0002	11	32568.0001	7		
01362.0000	13	05868.0000	11	32569.0001	7		
01380.0000	5	05871.0001	9	32570.0000	7		
01382.0002	5,9	05872.0000	9	33735.0002	5		
01388.0000	13	05876.0000	5,9	34107.0000	11		
01509.0000	13	05880.0000	11	34213.0000	11		
01512.0000	13	05881.0000	11	35184.0000	11		
01516.0000	13	05882.0000	11	37711.1002	13		
01518.0000	5	05884.0000	7	37881.0000	5		
01533.0000	13	05887.0000	15	38278.1002	7		
01539.0000	11	05887.0001	15	39586.1000	7		
01686.0000	13	05892.0000	13	40699.0004	15		
01908.0000	13	05893.0000	13	41790.1000	13		
02308.0000	5,7,13	05904.0001	15	41947.0000	13		
02311.0000	5	05951.0000	11				
02312.0000	11	05954.0000	11				
02313.0000	11	05965.0000	11				
02314.0000	11	05995.0000	11				
02322.0002	9	06536.0000	13				
02327.0002	11	10173.0000	5				
02328.0002	11	10239.0000	5				
02330.0001	11	11029.1005	11				
02434.1000	9	11029.1006	11				
02620.1034	13	11180.0000	11				
02620.1036	13	11185.0001	11				
02620.1046	13	11191.0001	11				
02620.1049	13	11192.0000	11				
02999.0000	7	11628.0000	9				
04831.0000	13	20545.0000	5				
05185.0000	15	20631.0000	11				
05188.0002	15	21619.1000	5				
05741.0000	7	21619.1002	5				