

BUNN® ***COMBO GRINDER***



DISCONTINUED VERSION
Parts listed in this catalog
may no longer be available.

ILLUSTRATED PARTS CATALOG

Designs, materials, weights, specifications, and dimensions for equipment or replacement parts are subject to change without notice.

BUNN-O-MATIC CORPORATION

POST OFFICE BOX 3227

SPRINGFIELD, ILLINOIS 62708-3227

PHONE: (217) 529-6601 FAX: (217) 529-6644

WARRANTY

Bunn-O-Matic Corp. ("Bunn") warrants the equipment manufactured by it to be commercially free from defects in material and workmanship existing at the time of manufacture and appearing within one year from the date of installation. In addition:

1.) Bunn warrants electronic circuit and/or control boards to be commercially free from defects in material and workmanship for two years from the date of installation.

2.) Bunn warrants the compressor on refrigeration equipment to be commercially free from defects in material and workmanship for two years from the date of installation.

3.) Bunn warrants that the grinding burrs on coffee grinding equipment will grind coffee to meet original factory screen sieve analysis for three years from date of installation or for 30,000 pounds of coffee, whichever comes first.

This warranty does not apply to any equipment, component or part that was not manufactured by Bunn or that, in Bunn's judgement, has been affected by misuse, neglect, alteration, improper installation or operation, improper maintenance or repair, damage or casualty.

THE FOREGOING WARRANTY IS EXCLUSIVE AND IS IN LIEU OF ANY OTHER WARRANTY, WRITTEN OR ORAL, EXPRESS OR IMPLIED, INCLUDING, BUT NOT LIMITED TO, ANY IMPLIED WARRANTY OF EITHER MERCHANTABILITY OR FITNESS FOR A PARTICULAR PURPOSE. The agents, dealers or employees of Bunn are not authorized to make modifications to this warranty or to make additional warranties that are binding on Bunn. Accordingly, statements by such individuals, whether oral or written, do not constitute warranties and should not be relied upon.

The Buyer shall give Bunn prompt notice of any claim to be made under this warranty by telephone at (217) 529-6601 or by writing to Post Office Box 3227, Springfield, Illinois, 62708-3227. If requested by Bunn, the Buyer shall ship the defective equipment prepaid to an authorized Bunn service location. If Bunn determines, in its sole discretion, that the equipment does not conform to the warranty, Bunn shall repair the equipment with no charge for parts during the warranty period and no charge for labor by a Bunn Authorized Service Representative during the warranty period. If Bunn determines that repair is not feasible, Bunn shall, at its sole option, replace the equipment or refund the purchase price for the equipment.

THE BUYER'S REMEDY AGAINST BUNN FOR THE BREACH OF ANY OBLIGATION ARISING OUT OF THE SALE OF THIS EQUIPMENT, WHETHER DERIVED FROM WARRANTY OR OTHERWISE, SHALL BE LIMITED, AS SPECIFIED HEREIN, TO REPAIR OR, AT BUNN'S SOLE OPTION, REPLACEMENT OR REFUND.

In no event shall Bunn be liable for any other damage or loss, including, but not limited to, lost profits, lost sales, loss of use of equipment, claims of Buyer's customers, cost of capital, cost of down time, cost of substitute equipment, facilities or services, or any other special, incidental or consequential damages.

TABLE OF CONTENTS

TITLE	PAGE NO.
Hopper Lid and Slide Plate Assembly	6
Housing and Panels	4
Motor, Burr Housing and Bracket	10
Numerical Index	14

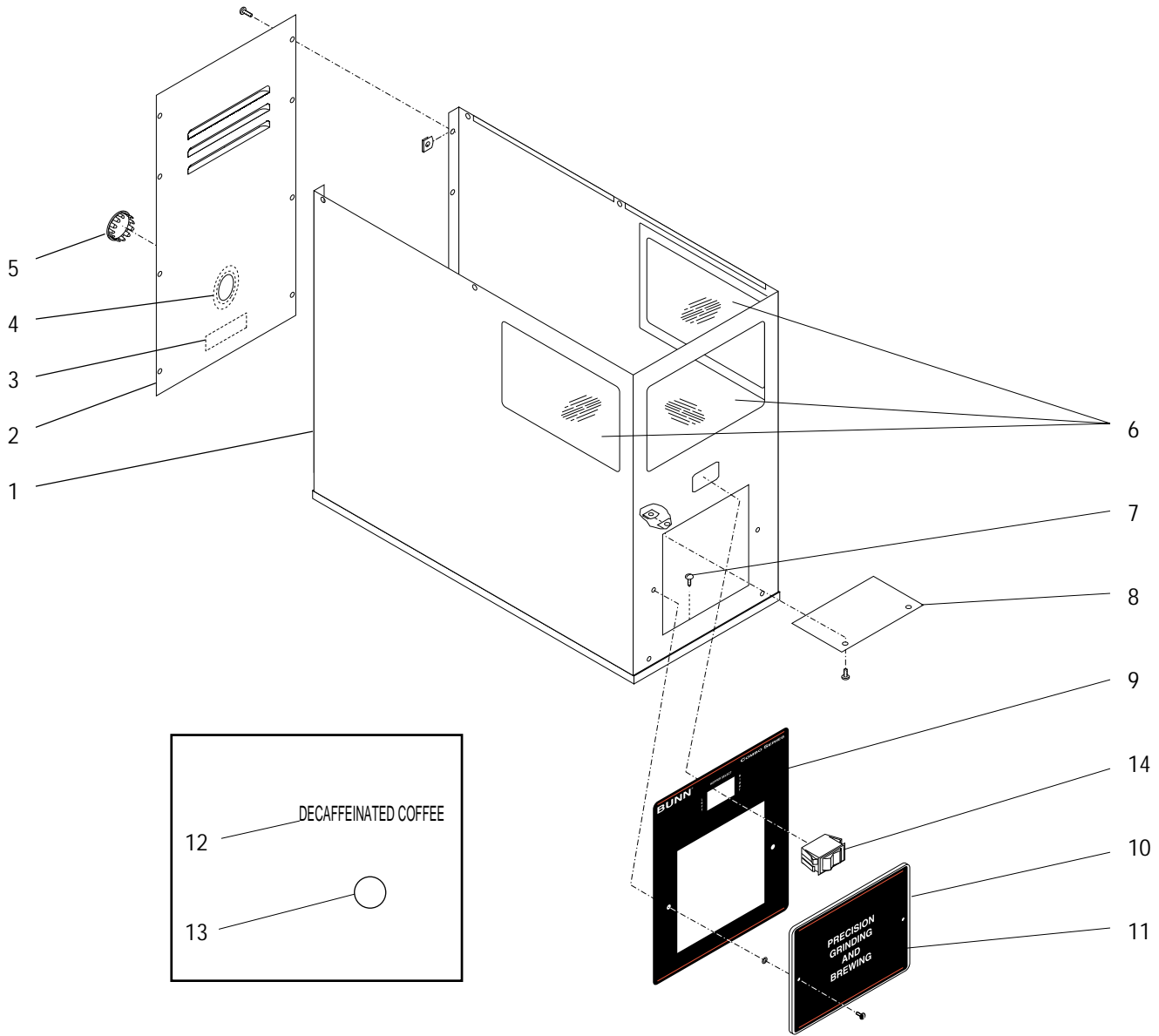

HOUSING AND PANELS

ITEM	PART NO.	QTY.	DESCRIPTION
1	25780.0000	1	Housing Assy W/Decal (Includes items 6 & 9) (SST)
	25436.0002	1	Housing Wldmt, Upper (Black) (Also order Items 6 & 9)
2	05844.1003	1	Rear Panel W/Decal (Includes item 3 & 4) (SST)
	05844.0004	1	Panel. Rear - Combo G/B (Black) (Also order items 3 & 4)
	01315.0000	8	Screw, Truss Head #8-32 x .375" (SST)
	02322.0002	8	Screw, TRH Sltd Blk OXD 8-32 (BLK)
	00917.0000	8	Fastener, J-Type #8-32
3	26227.0000	1	Decal, Model Combo Grinder Use With Model Combo Brewer
4	05884.0000	1	Decal, Motor Reset
5	02999.0000	1	Plug, Hole 1.19" Dia.(SST)
	25126.0000	1	Plug, Hole 1-19 Dia. (BLK)
6	05814.0001	3	Window Assy (Includes adhesive)
7	01315.0000	1	Screw, Truss Head #8-32 x .375"
8	05827.0000	1	Plate, Switch Shield
	02308.0000	2	Screw, Pan Head #8-32 x .375"
	00912.0000	2	Fastener, J-Type #8-32
9	25484.0000	1	Decal, Control Panel
10	21620.1009	1	Cover Assy W/Decal (Includes screws and washers below and item 11)
	01382.0002	2	Screw, Truss Head BLK #6-32 x .375"
	01518.0000	2	Washer, Screw Retaining #6
11	26079.0000	1	Decal, Precision Grinding & Brewing
12	00879.0000	1	Decal, Decaffeinated Coffee (As required)
13	05940.0000	1	Decal, Orange Dot (As required)
14	05789.0000	1	Switch, Hopper Selector
15	25758.0000	1	Wiring Harness, Grinder (Not illustrated)

HOPPER, LID & SLIDE PLATE ASSEMBLY

ITEM	PART NO.	QTY.	DESCRIPTION
-	24243.1006	1	Hopper Assy, 120V (Includes items 1 thru 25)
	24243.0007	1	Hopper Ay, w/slides, Lid (BLK)(Includes Items 1 thru 25)
1	24399.0000	1	Lid Assy, Hopper
	24399.0001	1	Lid Assy, Hopper Tamper Resistant
	24399.0002	1	Lid Assy, Hopper Locking
	05945.0005	1	Lid Wldmt, Hopper (Black) (Also order Items 2 & 3)
	02328.0000	4	Screw, Pan Head #6 - 32 x .38"
2	00725.0000	2	Knob
3	05876.0000	2	Decal, Caution
4	05960.0000	1	Hopper Assy W/Inserts
	02367.0000	2	Screw, Truss Head #6 - 32 x .62"(SST)
	01388.0002	2	Screw, TRH Sltd Blk Oxd 6-32x.75
	01380.0000	2	Screw, Truss Head # 6 - 32 x .50"
	02323.0000	2	Screw, TRH Sltd Blk Oxd 6-32x.5
	00991.0002	4	Nut, Lock #6-32
5	23917.0000	2	Limit Thermostat
	01311.0000	4	Screw, Truss Head #8 - 32 x .25"
6	05939.0003	2	Solenoid Assy (120V)
	01315.0000	8	Screw, Truss Head #8 - 32 x .38"
	01511.0000	8	Lockwasher, External Tooth #8
	01501.0000	8	Washer, Flat
7	23923.0000	2	Washer, Fiber .063" Thick
8	23918.0000	2	Spring
9	23922.0000	2	Washer, Retaining .035" Thick
10	05969.0000	2	Slide Plate/Linkage Assy (Includes items 11 thru 19)
11	- - - - -	2	Plunger (Not available seperately order item 10)
12	02858.0000	2	Pin, Spring .125" x .50"
13	23919.0000	2	Snap Ring
14	01403.0000	8	E-Ring
15	05914.0002	2	Pin, Linkage .19" x .39"
16	05911.0001	2	Link, Slide Plate (Short)
17	05914.0001	2	Pin, Linkage .19" x .30"
18	05910.0000	2	Link, Slide Plate (Long)
19	05912.0000	2	Slide Plate
20	05959.0001	1	Mounting Panel Assy, Slide Plate (Includes items 21, 22 & 23)
	01317.0000	5	Screw, Truss Head #8 - 32 x .50"
	01370.0000	1	Screw, Pan Head #8 - 32 x .75"
21	23920.0000	2	Pin, Pivot

(Continued)

(Continued)

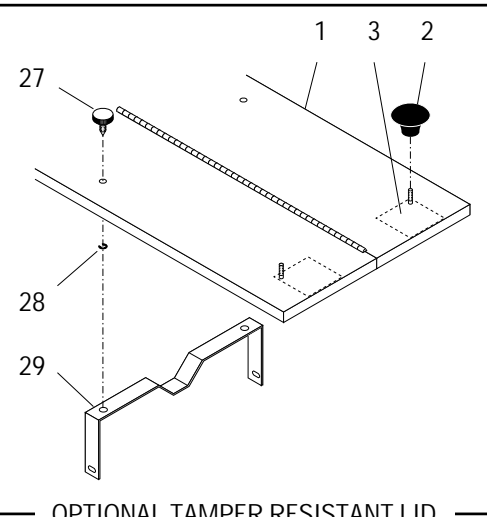

OPTIONAL TAMPER RESISTANT LID

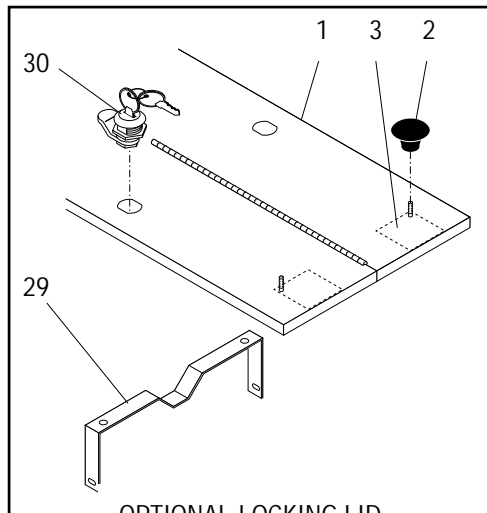

OPTIONAL LOCKING LID

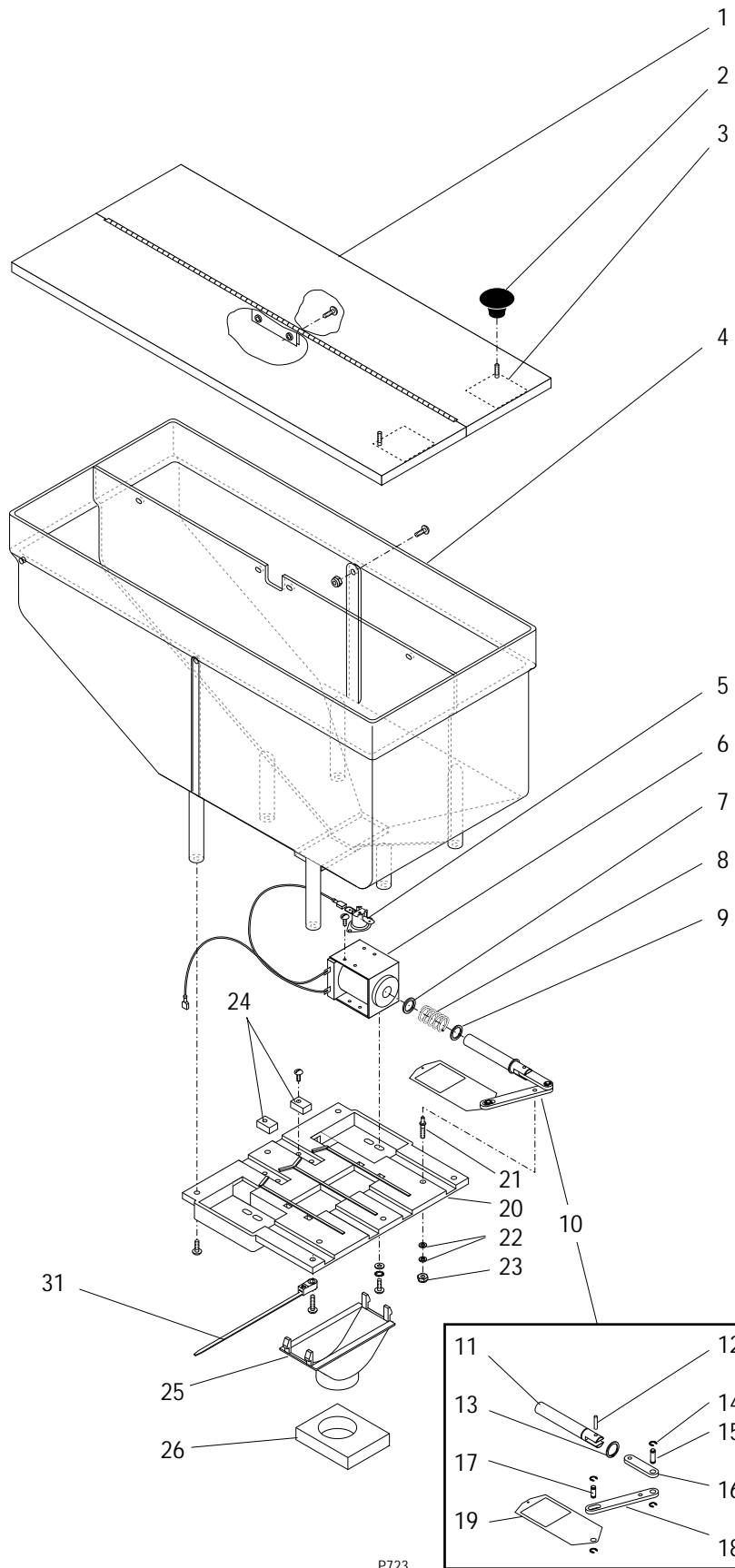

P723

HOPPER, LID & SLIDE PLATE ASSEMBLY

ITEM	PART NO.	QTY.	DESCRIPTION
22	01547.0000	4	Spacer .062" Thick
23	00991.0000	2	Nut, Elastic Lock # 8 - 32
24	23921.0000	2	Block, Stop
	02336.0000	2	Screw, Truss Head #4 - 32 x .38"
25	05916.0000	1	Collector
26	21457.0000	1	Gasket, Burr Housing/Collector
27	01402.0000	2	Thumb Screw
28	01403.0000	2	E-Ring
29	05971.0000	1	Bracket, Lid Locking
30	11628.0000	2	Lid Lock Assy (Includes Keys) (Additional Keys should be made locally)
31	26329.0000	1	Cable Tie

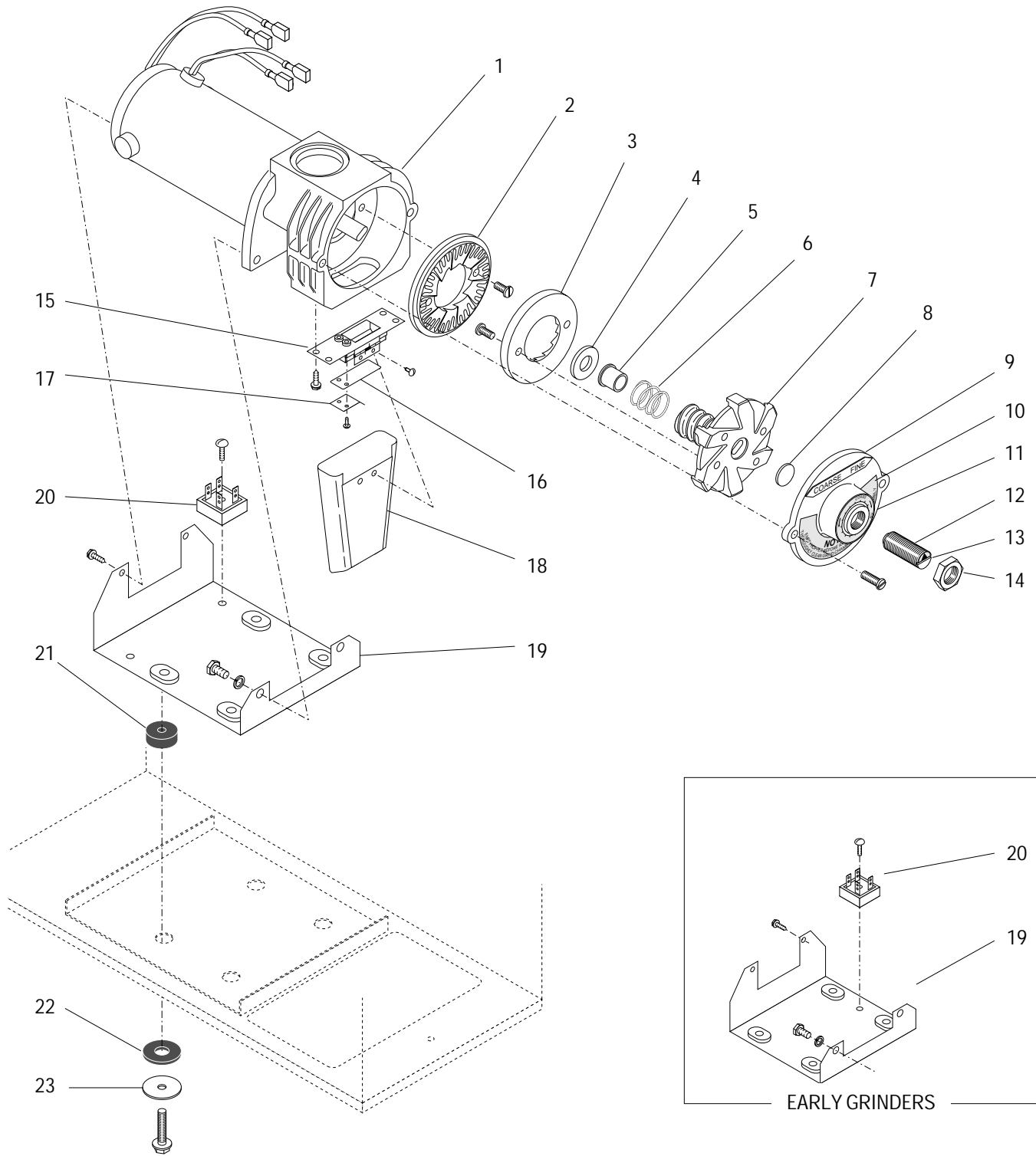

MOTOR, BURR HOUSING AND MOUNTING BRACKET

ITEM	PART NO.	QTY.	DESCRIPTION
-	-----	1	Motor/Burr Housing Assy (Includes item1 thru 14) (Early Grinders) (No longer available order 24900.0100)
	26817.1000	1	Motor/Burr Housing Assy (Includes item1 thru 14) (Late Grinders)
	01330.0000	2	Screw, Slotted Hex Head #10 - 32 x .375"
	02326.0002	2	Capscrew, Hex Head .25" - 20 x .50"
	01538.0000	2	Lockwasher, Split .25"
1	-----	1	Motor, Grinder/Burr Housing & Terminals (Early Grinders) (No longer available order 24900.0100)
	26819.0000	1	Motor, Grinder/Burr Housing & Terminals (Late Grinders)
2	-----	1	Burr (Not available. Order item 24)
	02314.0000	2	Screw, Pan Head .25" - 20 x .50"
3	-----	1	Burr (Not available. Order item 24)
	20669.0000	2	Screw, BDG Head #10 - 32 x .29"
4	21613.0000	1	Washer, .875" O.D. x .406" I.D. (Early Grinders)
	26768.0000	1	Washer, 1.125" O.D. x .531" I.D. (Late Grinders)
5	20667.0000	1	Bushing, Spring Retainer (Early Grinders)
	26769.0000	1	Bushing, Spring Retainer (Late Grinders)
6	20666.0000	1	Spring (Early Grinders)
	26770.0000	1	Spring (Late Grinders)
7	25916.0000	1	Burr Auger Rotor/Spring Assy (Includes item 4, 5 & 6) (Early Grinders)
	25916.0001	1	Burr Auger Rotor/Spring Assy (Includes item 4, 5 & 6) (Late Grinders)
8	20670.0000	1	Disc, Load
9	25915.0000	1	Cap W/Decals, Burr Housing (Includes items 10 & 11)
	25914.0000	1	Cap & Adjusting Screw W/Decals, Burr Housing (Includes items 10 thru 14)
	11064.0000	2	Screw, Fillister Head .25" - 20 x .75"
10	05868.0000	1	Decal, Housing Cover
11	05880.0000	1	Decal, Grind Indicator
12	25638.0000	1	Adjusting Screw (Also Order item13)
13	05796.0000	1	Decal, Adjusting Screw
14	00989.0000	1	Nut, Locking
15	25445.0000	1	Bracket, Chute Mounting (Also order item 26)
	02330.0000	4	Screw, Slotted Hex Head #10-24 x .50" (Also order item 25)
16	25474.0000	1	Dechaffer Plate
17	27503.0000	1	Dechaffer Bracket
	02327.0002	2	Screw, Pan Head #4 - 40 x .312"
18	28032.0000	1	Chute
	02328.0002	2	Screw, Pan Head #6 - 32 x .188"
19	25412.0000	1	Bracket, Motor Mounting (Early Grinders)
	25412.0001	1	Bracket, Motor Mounting (Late Grinders)

(Continued)

(Continued)

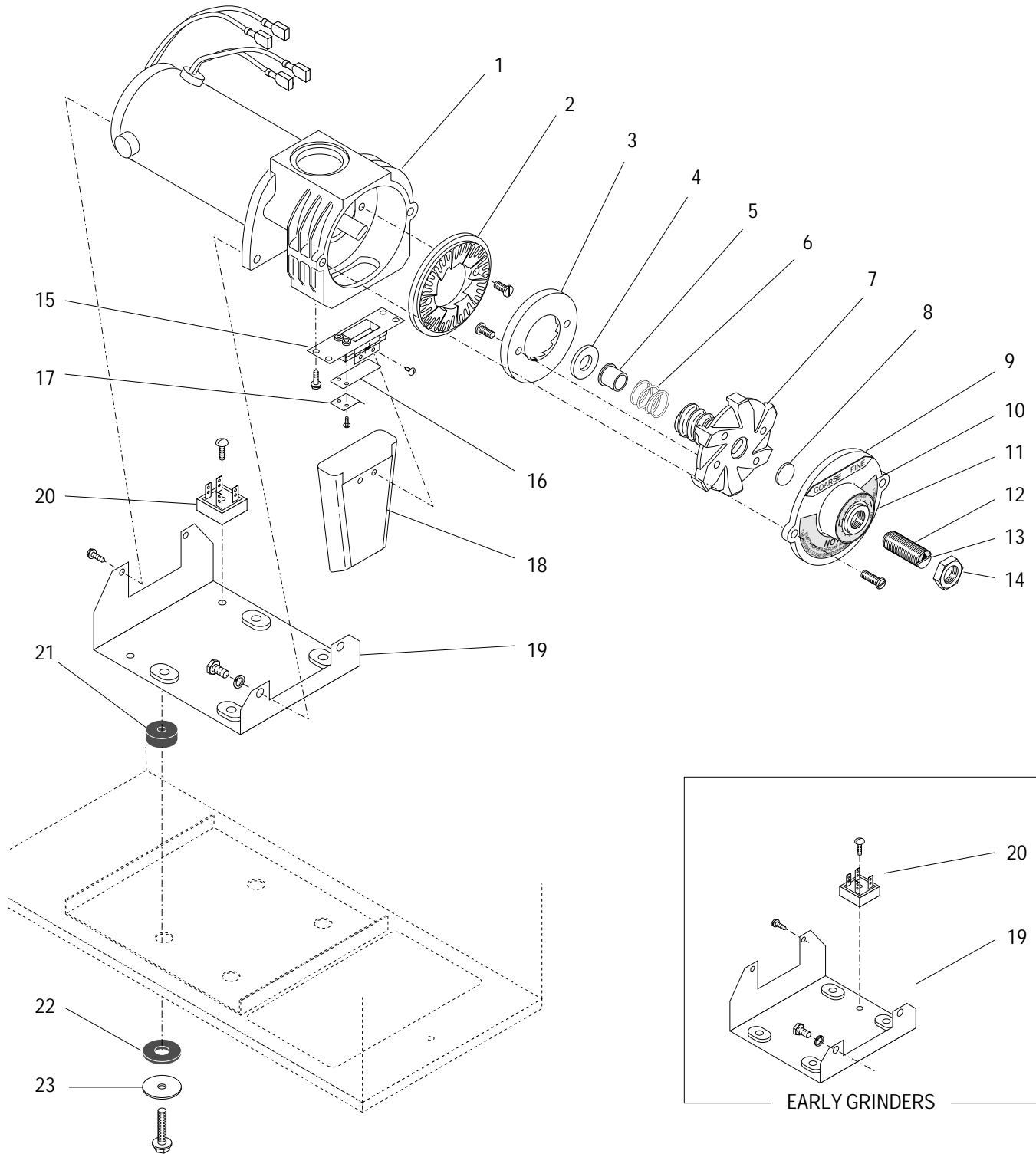

MOTOR, BURR HOUSING AND MOUNTING BRACKET

ITEM	PART NO.	QTY.	DESCRIPTION
20	22126.0000	1	Rectifier, Bridge Single Phase
	01331.0003	1	Screw, Round Head #10 - 32 x .75"
21	05881.0000	4	Bushing
22	05882.0000	4	Washer, 1.50 Dia.
23	02312.0000	4	Screw, Hex Washer Head .312"- 18 x 1.50"
	01539.0000	4	Washer, Flat
24	05861.1002	1	Kit, Burr (Includes items 2, 3 and mounting screws)
25	M2514.0001	-	Thread Lock, 242 Blue .5 ml
26	M2509.1000	-	Sealant, Clear 732 RTV 10.3 oz

} Not illustrated

NUMERICAL INDEX

PART NO.	PAGE NO.	PART NO.	PAGE NO.	PART NO.	PAGE NO.	PART NO.	PAGE NO.
00725.0000	7	05914.0002	7	M2509.1000	13		
00879.0000	5	05916.0000	9	M2514.0001	13		
00912.0000	5	05939.0003	7				
00917.0000	5	05940.0000	5				
00989.0000	11	05945.0005	7				
00991.0000	9	05959.0001	7				
00991.0002	7	05960.0000	7				
01311.0000	7	05969.0000	7				
01315.0000	5,7	05971.0000	9				
01317.0000	7	11064.0000	11				
01330.0000	11	11628.0000	9				
01331.0003	13	20666.0000	11				
01370.0000	7	20667.0000	11				
01380.0000	7	20669.0000	11				
01382.0002	5	20670.0000	11				
01388.0002	7	21457.0000	9				
01402.0000	9	21613.0000	11				
01403.0000	7,9	21620.1009	5				
01501.0000	7	22126.0000	13				
01511.0000	7	23917.0000	7				
01518.0000	5	23918.0000	7				
01538.0000	11	23919.0000	7				
01539.0000	13	23920.0000	7				
01547.0000	9	23921.0000	9				
02308.0000	5	23922.0000	7				
02312.0000	13	23923.0000	7				
02314.0000	11	24243.1006	7				
02322.0002	5	24243.0007	7				
02323.0000	7	24399.0000	7				
02326.0002	11	24399.0001	7				
02327.0002	11	24399.0002	7				
02328.0000	7	25126.0000	5				
02328.0002	11	25412.0000	11				
02330.0000	11	25412.0001	11				
02336.0000	9	25436.0002	5				
02367.0000	7	25445.0000	11				
02858.0000	7	25474.0000	11				
02999.0000	5	25484.0000	5				
05789.0000	5	25638.0000	11				
05796.0000	11	25758.0000	5				
05814.0001	5	25780.0000	5				
05827.0000	5	25914.0000	11				
05844.1003	5	25915.0000	11				
05844.0004	5	25916.0000	11				
05861.1002	13	25916.0001	11				
05868.0000	11	26079.0000	5				
05876.0000	7	26227.0000	5				
05880.0000	11	26329.0000	9				
05881.0000	13	26768.0000	11				
05882.0000	13	26769.0000	11				
05884.0000	5	26770.0000	11				
05910.0000	7	26817.1000	11				
05911.0001	7	26819.0000	11				
05912.0000	7	27503.0000	11				
05914.0001	7	28032.0000	11				