

BUNN Espresso®

ES•1 AF

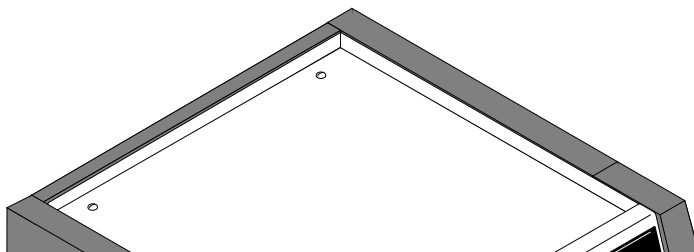

DISCONTINUED VERSION
Parts listed in this catalog
may no longer be available.

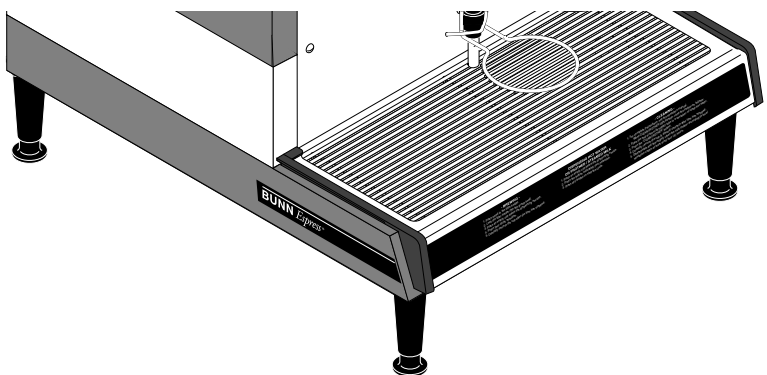

ILLUSTRATED PARTS CATALOG

Designs, materials, weights, specifications, and dimensions for equipment or replacement parts are subject to change without notice.

BUNN-O-MATIC CORPORATION

POST OFFICE BOX 3227

SPRINGFIELD, ILLINOIS 62708-3227

PHONE: (217) 529-6601 FAX: (217) 529-6644

TABLE OF CONTENTS

Air, Brew, Hot Water, Steam Solenoids and Piping	14
Electrical and Operating Controls	22
Filter Holder Assembly	26
Frother Manifold and Components	18
Group Head and Piping	20
Numerical Index	28
Panels, Base and Legs	2
Pressure Guage and Piping	12
Pump and Piping	8
Refill Solenoid and Piping	10
Tank and Components	6

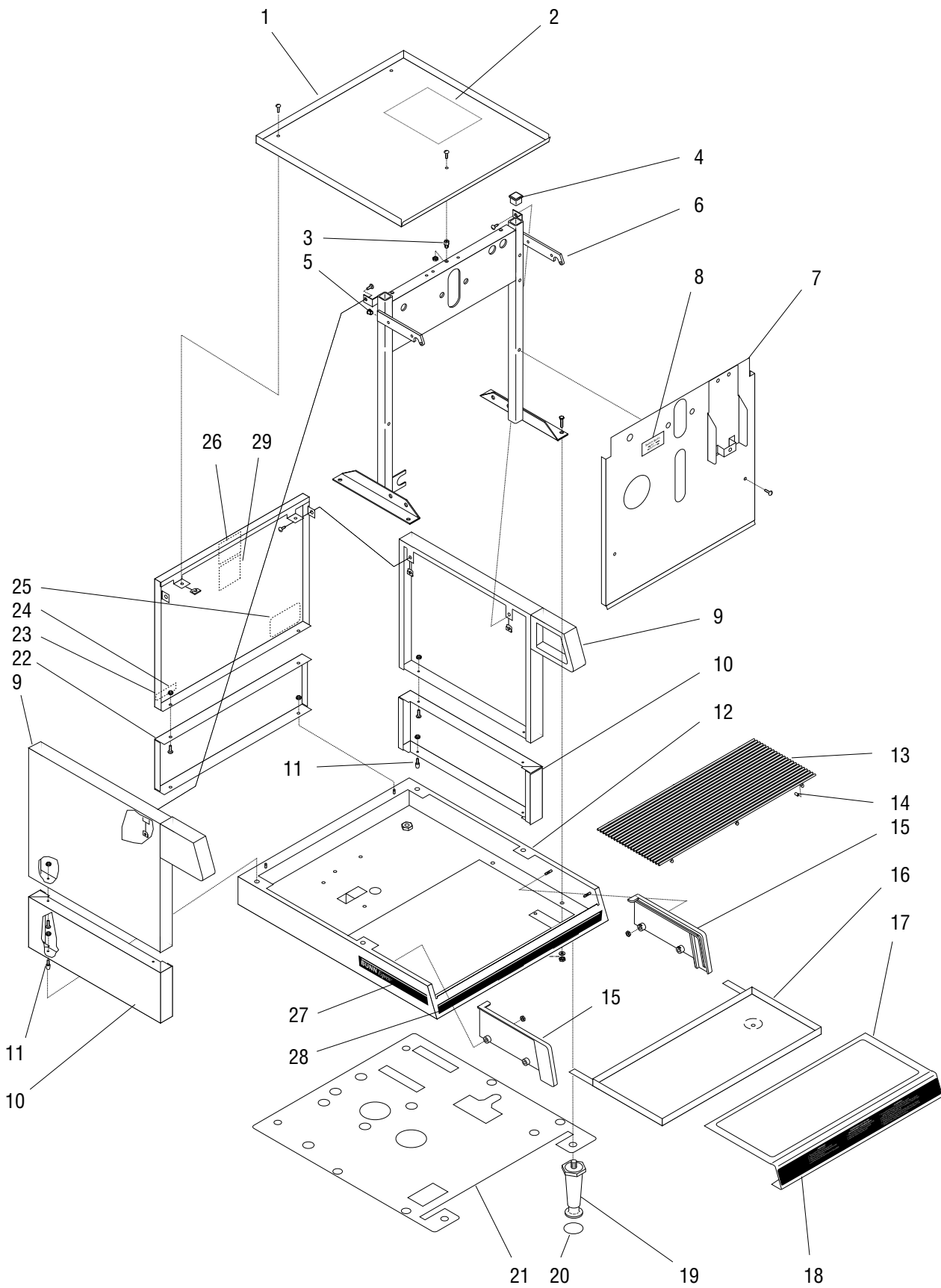

PANELS, BASE AND LEGS

ITEM	PART NO.	QTY.	DESCRIPTION
1	26737.0000	1	Panel, Top Cup Warmer (Includes items 2)
	24005.0200	1	Screw, Pan Head M4 x .7 x 6mm
	01387.0000	2	Screw, Truss Head #8-32 x .625"
	23638.0000	2	Fastener, U-Type
2	26564.0000	1	Decal, Electrical Schematic
3	24842.0000	1	Spacer, Top Panel
	24047.0400	1	Nut, Hex Keps M6
4	26196.0001	4	Plug, Square-BLK Plastic
5	00671.0000	-	Plug, .312" Hole Dia (Use as required)
6	26738.0000	1	Chassis (Includes items 4 & 5)
	24007.0000	4	Screw, Hex Head M6 x 1 x 10mm
	24027.0000	4	Washer, M6
	24047.0400	4	Nut, Hex Keps M6
7	26739.0000	1	Panel, Front (Includes item 8)
	24006.1000	2	Screw, Cross Recessed Pan Head M5 x 8mm
8	22723.0000	1	Decal, Run-Program
9	23669.0000	1	Panel, Side-Left
	23668.0000	1	Panel, Side-Right
	01387.0000	2	Screw, Slotted Truss Head #8 x .625"
	23638.0000	2	Fastener, U-Type
10	25554.0000	2	Panel, Side Extension
	24003.1000	4	Screw, Cross Recessed Pan Head M3 x 8mm
	24043.0400	4	Nut, Hex Keps M3
11	23648.0000	4	Pin, Side Panel Extension Locating
	24043.0400	4	Nut, Hex Keps M3
12	26746.0000	1	Base (Includes Items 27 & 28)
13	25559.0000	1	Wireform, Drip Tray
14	12919.0003	6	Cap
15	23654.0000	1	Guide, Drip Tray-Left
	23653.0000	1	Guide, Drip Tray-Right
	24045.0101	4	Nut, Hex M4
16	23655.0001	1	Drip Tray
17	26740.0000	1	Grate, Drip Tray (Includes item 18)
18	26601.0000	1	Decal, Instruction
19	26528.0000	4	Leg, 4.0" Adjustable BLK Plastic
20	03996.0000	4	Pad, Anti Skid-Rubber
21	23467.0001	1	Plate, Base

} See Item 30

(Continued)

(Continued)

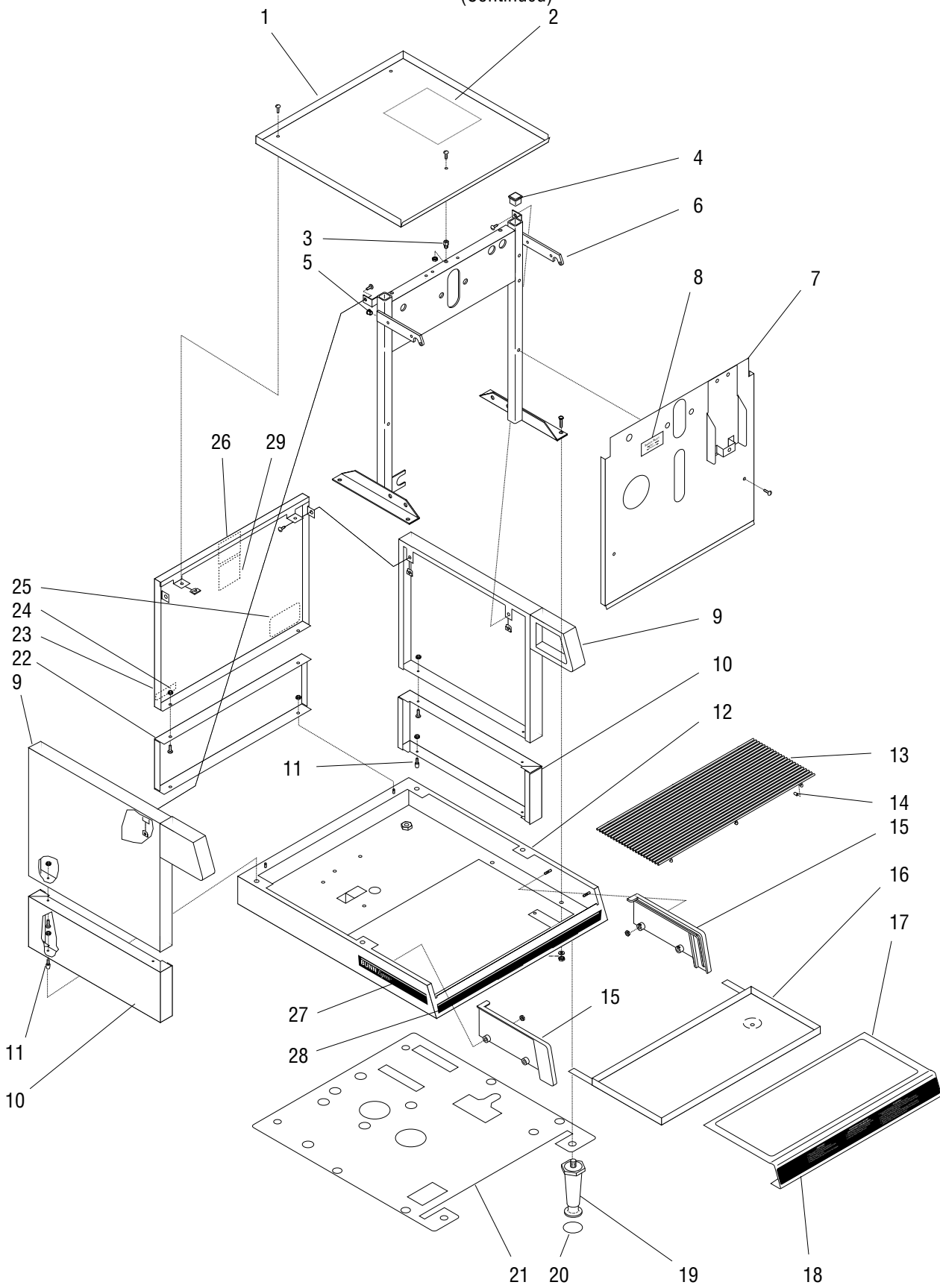

PANELS, BASE AND LEGS

ITEM	PART NO.	QTY.	DESCRIPTION
22	25555.0000	1	Panel, Rear Extension
	24005.0002	2	Screw, Hex Head M4 x .70 x 8mm
	24045.0400	4	Nut, Hex Keps M4
23	26741.0000	1	Panel, Rear (Includes items 24, 25, 26 & 29))
	01387.0000	2	Screw, Truss Head Slotted #8-32 x .625"
	23638.0000	2	Fastener, U-Type
24	24247.0000	1	Decal, Notice-Operating Pressure
25	00656.0000	1	Decal, Comply To Plumbing Code
26	12652.0000	1	Decal, Electrical Warning
27	23445.0001	1	Decal, BUNN Espresso
28	23445.0002	1	Decal
29	00986.0002	1	Decal, Electrical Warning
30	13255.0003	-	Kit, Leg 4.0" Adjustable BLK - Plastic (Includes four of items 19 & 20)

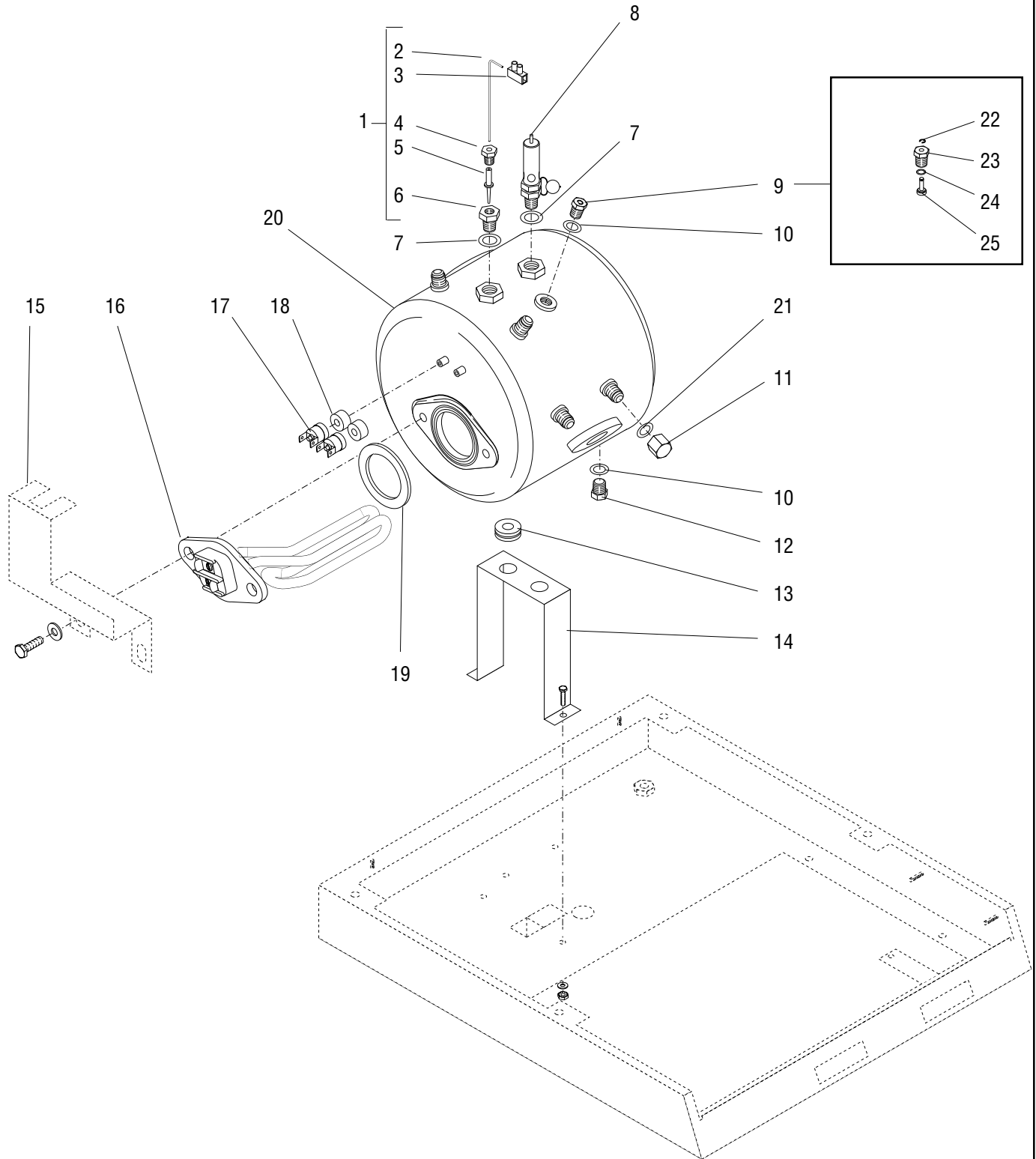

TANK AND COMPONENTS

ITEM	PART NO.	QTY.	DESCRIPTION
1	23605.0001	1	Probe Assembly (Includes items 2 thru 6. Also order item 7)
2	23607.0000	1	Probe, Liquid Level
3	22814.0000	1	Terminal Block
4	23629.0000	1	Nut, Level Probe Compression
5	23608.0000	1	Grommet, Liquid Level Probe
6	23606.0001	1	Nut, Level Probe Mounting - Plated
7	23628.0000	2	Washer, Sealing
8	25185.0000	1	Valve, Pressure Relief (Also order item 7)
9	23603.0000	1	Valve, Compensation (Also order item 10)
10	24030.0001	2	Washer, Sealing
11	22815.0001	1	Cap, .25 BSPP
12	23601.0001	1	Plug, Tank Drain - Plated (Also order item 10)
13	02536.0000	2	Grommet, Tank Mounting .375 I.D.
14	25562.0000	1	Bracket, Tank Mounting
	24006.0001	2	Screw, Hex Head M5 x .8 x 15mm
	24026.0001	2	Washer, Flat M5
	24046.0400	2	Nut, Hex Keps M5
15	-----	1	Bracket, Pressure Switch Mounting (See Electrical and Operating Controls)
16	24274.1000	1	Heater, Tank 120V 1785W
	23934.0000	2	Screw, Hex Head .375"-16 x 1"
	24029.0000	2	Washer, Flat M10
17	25035.0000	2	Thermostat, Limit
18	25186.0000	2	Spacer, Limit Thermostat - Brass
19	23600.0000	1	Gasket, Tank Heater
20	23647.0001	1	Tank, Plated
21	22868.0000	1	Washer, Sealing - Copper
22	26209.0000	1	E-Ring, Valve Steam
23	-----	1	Housing (Not Available. Order item 9)
24	23586.0000	1	O-Ring, Valve Stem
25	-----	1	Stem, Valve (Not Available. Order item 9)

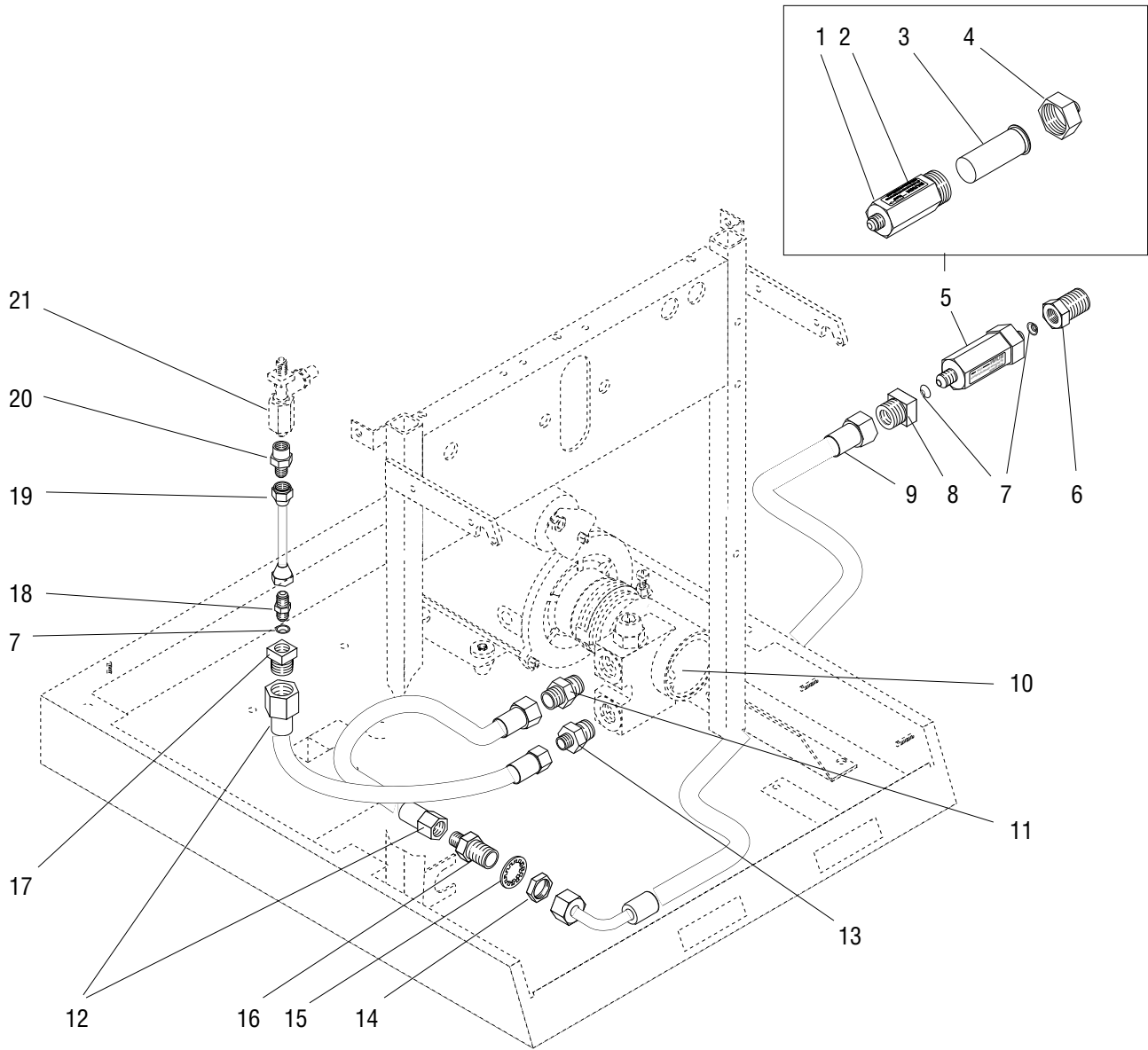

PUMP AND PIPING

ITEM	PART NO.	QTY.	DESCRIPTION
1	-----	1	Housing, Water Strainer (Not Available. Order item 5)
2	22267.0002	1	Decal, Strainer
3	23721.0000	1	Screen
4	22249.0000	1	Cap, Water Strainer -End
5	23820.1000	1	Water Strainer Assembly (Includes items 1 thru 4)
6	24682.0000	1	Adapter, .25" Female Flare x .375 NPT
7	24684.0000	3	Sealing Washer
8	24683.0000	1	Adapter, .25" Female Flare x .375 BSPP
9	24386.0000	1	Hose Kit, Water Inlet
10	-----	1	Motor And Pump Assembly (See Electrical and Operating Controls)
11	22905.0001	1	Fitting, Pump Inlet - Plated .375 BSPP x .375 BSPP
12	25267.0000	2	Hose Assembly Pump Inlet - Outlet
13	23540.0001	1	Fitting, Pump Outlet - Plated .250 BSPP x .375 BSPP
14	23933.0000	1	Nut, Jam .375 BSPP - Brass
15	01514.0000	1	Lockwasher, Internal Tooth .625" I.D.
16	23610.0001	1	Fitting, Bulkhead Inlet - Plated
17	24683.0001	1	Adapter, .25" Female Flare x .375 BSPP - Plated
18	00436.0001	1	Union, .25" Male Flare - Plated
19	25587.0000	1	Tube Assembly, Pump Outlet
20	00445.0001	1	Connector, .25" Male Flare x .125 FPT
21	-----	1	Check Valve Assembly (See Refill Solenoid and Piping)
22	24744.0000	1	Strainer Kit (Includes items 5, 6, two of item 7 and item 8)

See item 22

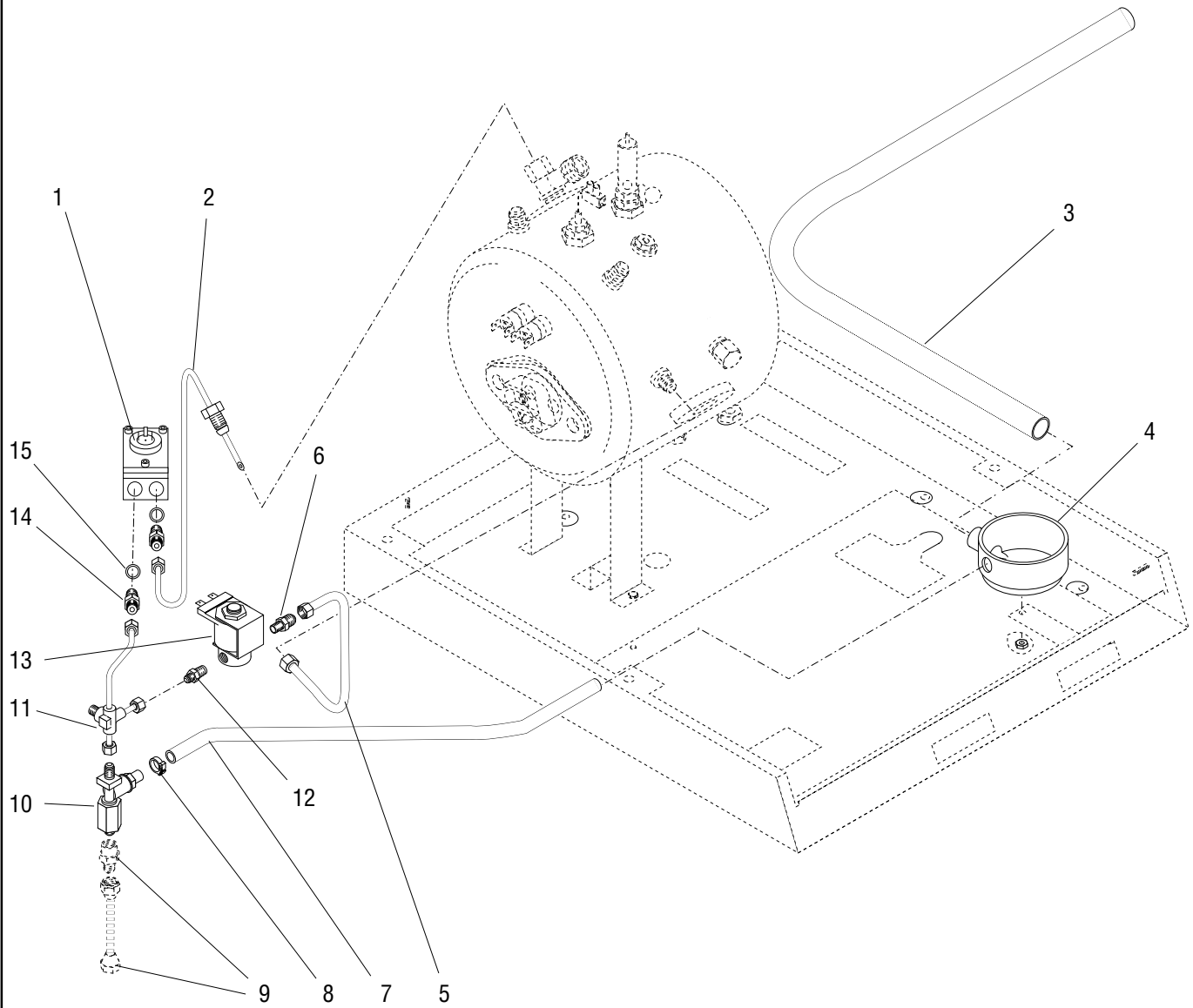

REFILL SOLENOID AND PIPING

ITEM	PART NO.	QTY.	DESCRIPTION
1	24641.0000	1	Flow Meter, Volumetric (Also order item 15)
2	23614.0000	1	Tube Assembly, Flow Meter to Tank
3	22603.0000	1	Hose, Drain - Plastic
4	23634.0000	1	Cup, Drain
	24045.0101	1	Nut, Hex M4 - Plated
5	23615.0001	1	Tube Assembly, Refill Solenoid To Tank
6	23569.0000	1	Fitting, Refill Solenoid Outlet
7	-----	1	Tube, Silicone .312" I.D. x .438" O.D. x 17" (Order item 16)
8	12422.0004	1	Clamp, Hose .43"/.48" I.D.
9	-----	1	Tube And Fitting (See Pump and Piping)
10	23563.0001	1	Check Valve Assembly, Water Inlet
11	23620.0000	1	Tube Assembly, Check Valve - Refill Solenoid - Flow Meter
12	23567.0001	1	Fitting, Refill Solenoid Inlet
13	21920.0000	1	Valve, Solenoid 120V
14	23624.0001	2	Fitting, Flow Meter (Also order item 15)
15	22868.0000	2	Washer, Sealing
16	03236.1001	-	Tube, Silicone .312" I.D. x .438" O.D. x 36" LG
	03236.1002	-	Tube, Silicone .312" I.D. x .438" O.D. x 120" LG
	03236.1003	-	Tube, Silicone .312" I.D. x .438" O.D. x 60" LG
17	21000.0524	1	Lead W/Terminals, 18AWG BLK 3.50" LG - Flow Meter Ground (Not Illustrated)

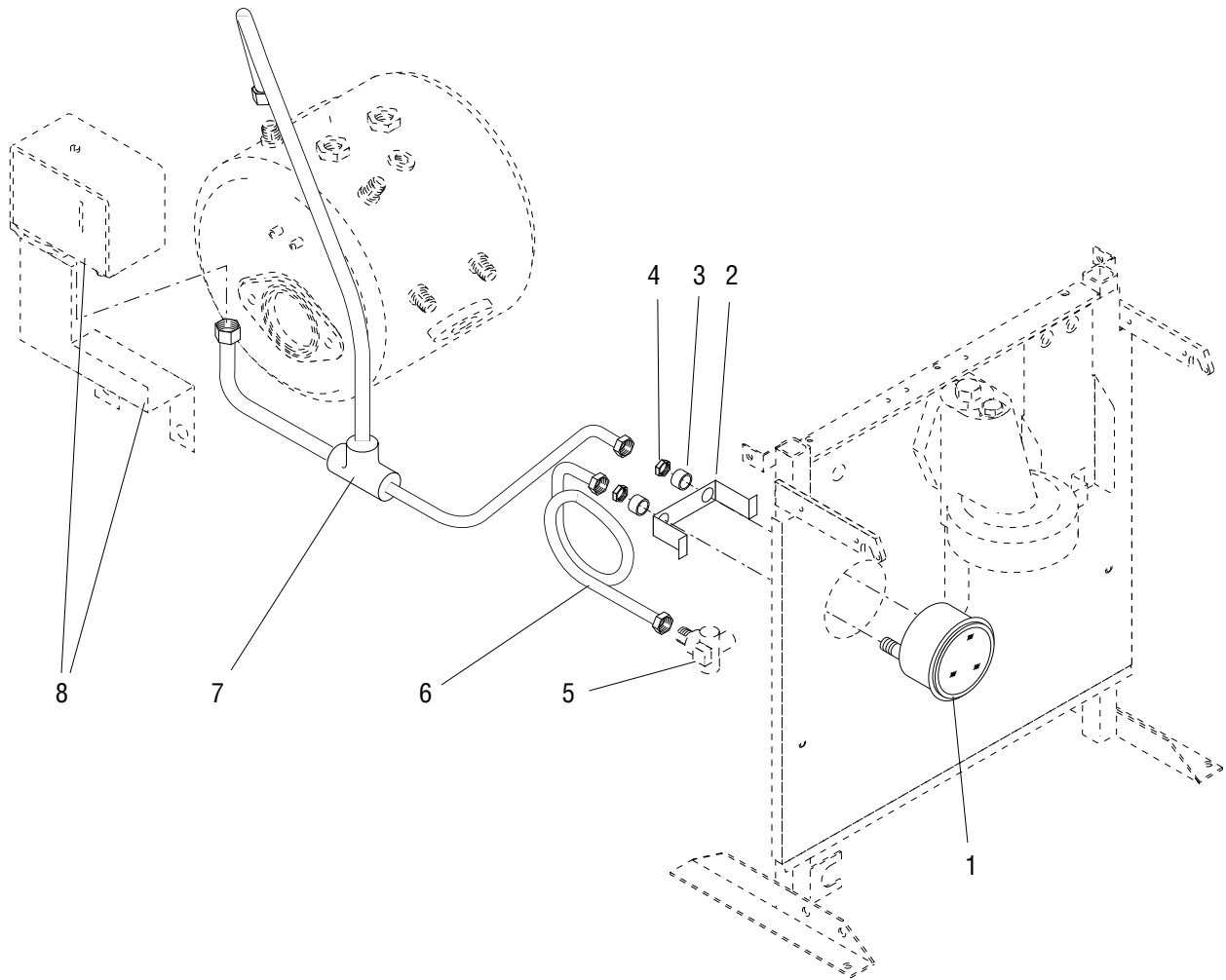

PRESSURE GAUGE AND PIPING

ITEM	PART NO.	QTY.	DESCRIPTION
1	24210.0000	1	Gauge, Pressure
2	24211.0000	1	Bracket, Mounting
3	24267.0000	2	Spacer
4	24284.0000	2	Nut, M10
5	-----	1	Tube Assembly (See Refill Solenoid and Piping)
6	23611.0000	1	Tube Assembly, Refill Tube to Gauge
7	23613.0000	1	Tube Assembly, Pressure Switch - Tank - Gauge
8	-----	1	Pressure Switch (See Electrical and Operating Controls)
9	24212.0000	-	Gauge Kit (Includes items 1 thru 4)

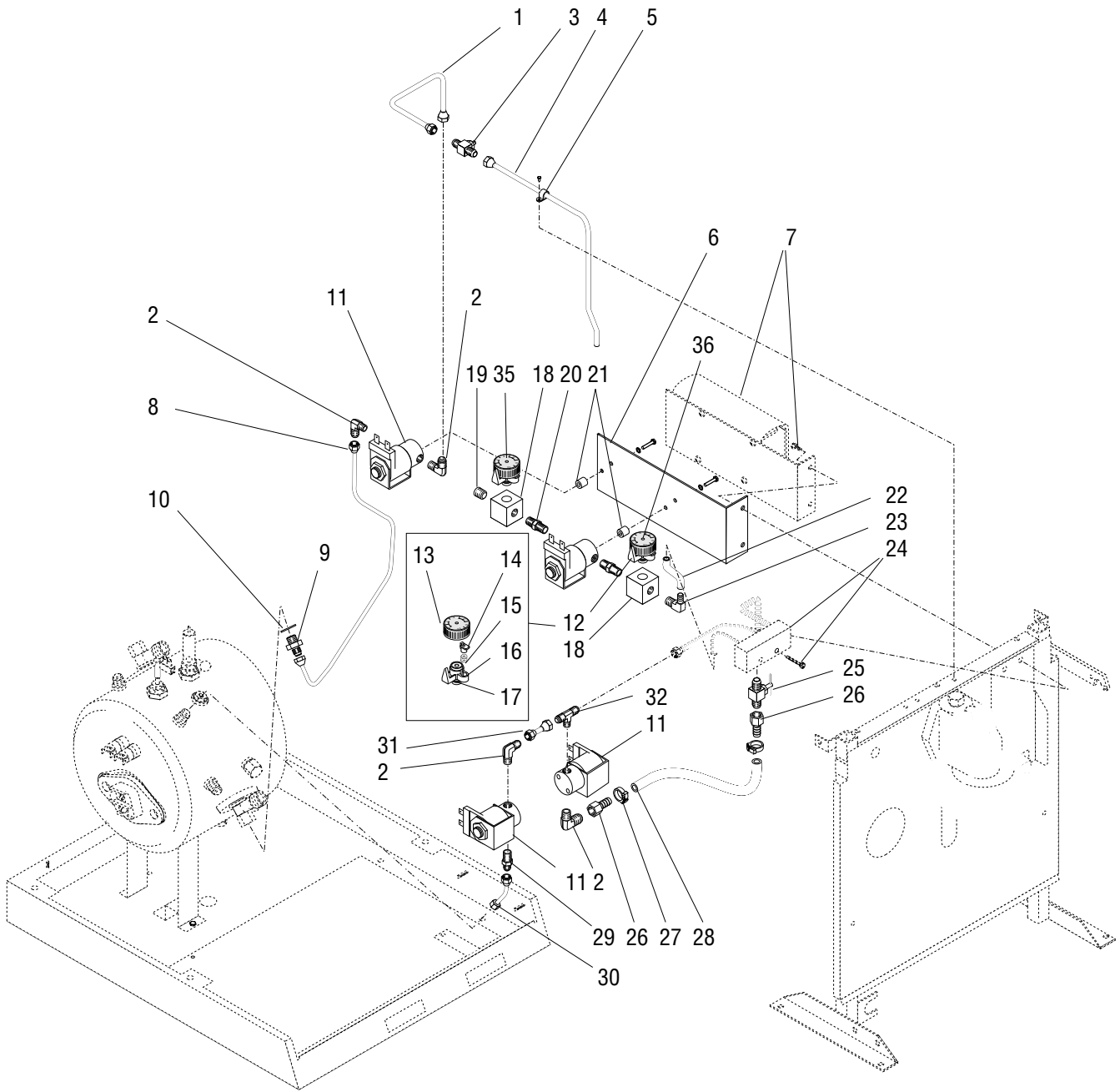

AIR, BREW, HOT WATER, STEAM SOLENOIDS AND PIPING

ITEM	PART NO.	QTY.	DESCRIPTION
1	26682.0000	1	Tube Assembly, Hot Water Solenoid to Needle Valve
2	00400.0001	4	Elbow, .25" Male Flare x .125" MPT - Plated
3	00484.0003	1	Valve, Needle .25" Male Flare - Plated
4	26683.0000	1	Tube Assembly, Needle Valve to Cup
5	26627.0000	1	Clamp, Tube .25" Dia
	24005.0002	1	Screw, Hex Head M4 x .70 x 8mm
6	25564.0000	1	Bracket, Solenoid Mounting
7	-----	-	Digital Brewer Control Board Assembly (See Electrical and Operating Controls)
8	25588.0000	1	Tube Assembly, Tank to Hot Water Solenoid
9	25569.0001	1	Connector, .25 MBSP x .25" Male Flare (Also order item 10)
10	24030.0001	1	Washer, Sealing
11	21920.0000	4	Valve, Solenoid - 120V
	21481.0000	4	Screw, Hex Head #10-32 x .625"
	01512.0000	4	Lockwasher, External Tooth #10
12	24706.1000	2	Air Adjustor Assembly (Includes Items 13 thru 17. Also order items 35 & 36)
13	-----	1	Knob Assembly, Adjustor (Not Available. Order item 12)
14	24732.0000	1	Retainer, Spring
15	24718.0000	1	Spring
16	-----	1	Body, Adjuster (Not Available. Order item 12)
17	24733.0001	1	O-Ring
18	25565.0000	2	Manifold, Air
19	00462.0001	1	Plug, Slotted Head .125" MPT - Plated
20	00412.0001	2	Nipple, Hex .125 MPT - Plated
21	01533.0005	4	Spacer, Nylon .375" O.D. x .19" I.D. x .375" LG
22	-----	1	Tube, Clear Vinyl .188" I.D x .312" O.D. x 3.2" LG (Order item 33)
23	00464.0001	1	Elbow, .125" MPT x .25" Barb - Plated
24	-----	1	Manifold, Frother (See Frother Manifold and Components)
25	00484.0001	1	Valve, Needle .25" Flare - Plated
26	00425.0000	2	Fitting, Swivel Nut .25" Flare x .25" Barb
27	12422.0000	2	Clamp, Hose .47"/.54" I.D.
28	-----	1	Hose, .250" I.D. x .50" O.D. x 9.5" LG (Order item 34)
29	00402.0001	1	Connector .25" Male Flare x .125" MPT

(Continued)

(Continued)

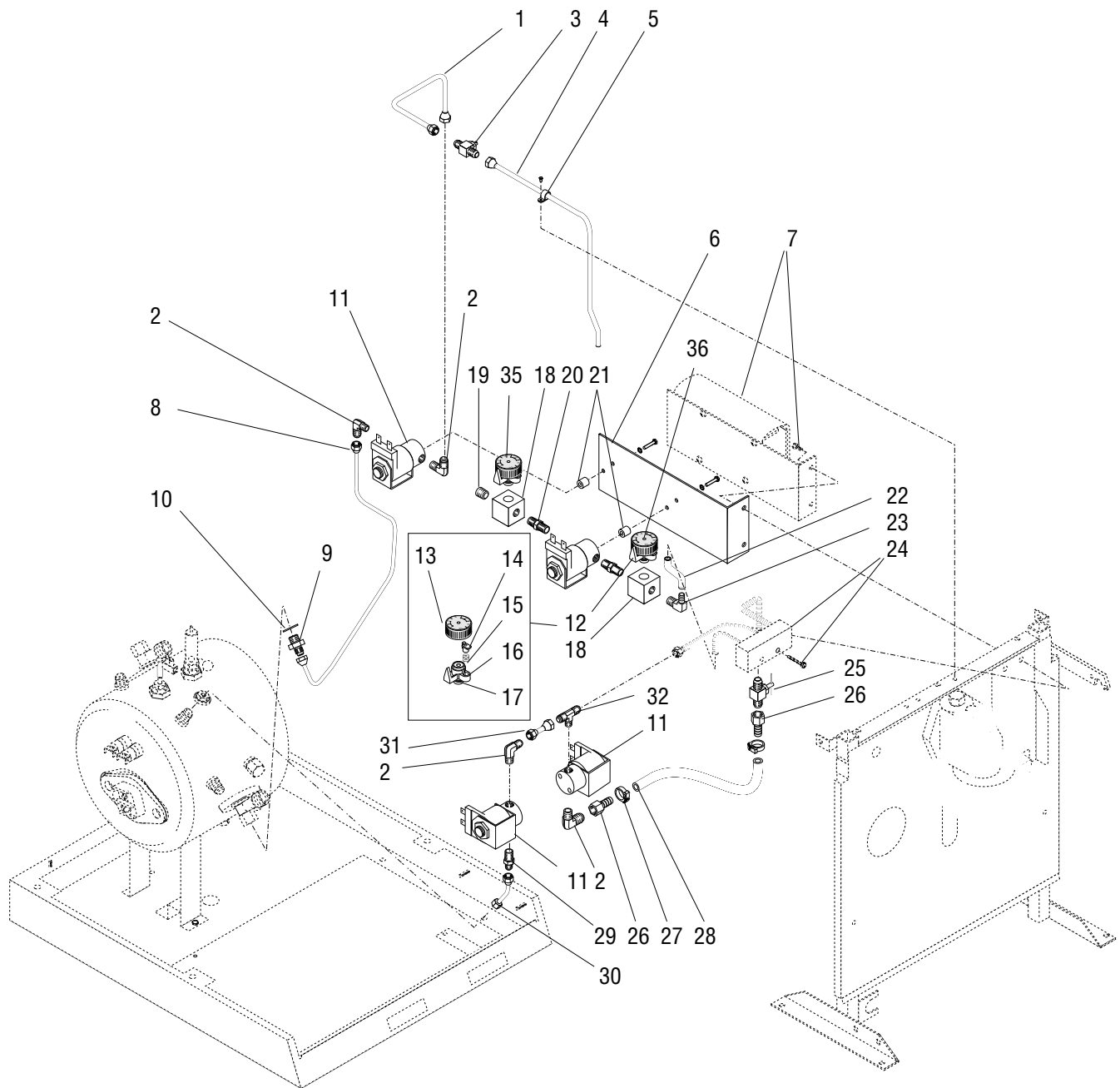

AIR, BREW, HOT WATER, STEAM SOLENOIDS AND PIPING

ITEM	PART NO.	QTY.	DESCRIPTION
30	25586.0000	1	Tube Assembly, Tank to Steam Solenoid
31	00483.0000	1	Tube Assembly, Solenoid Connecting
32	00431.0001	1	Tee, .25" Male Flare x .125" MPT
33	23782.1001	-	Tube, Clear Vinyl .188" I.D. x .312" O.D. x 24" LG
34	11707.1000	-	Tube, Silicone .250" I.D. x .50" O.D. x 12" LG
	11707.1001	-	Tube, Silicone .250" I.D. x .50" O.D. x 36" LG
	11707.1002	-	Tube, Silicone .250" I.D. x .50" O.D. x 120" LG
35	26602.0000	1	Decal, "F"
36	26002.0001	1	Decal, "SM"

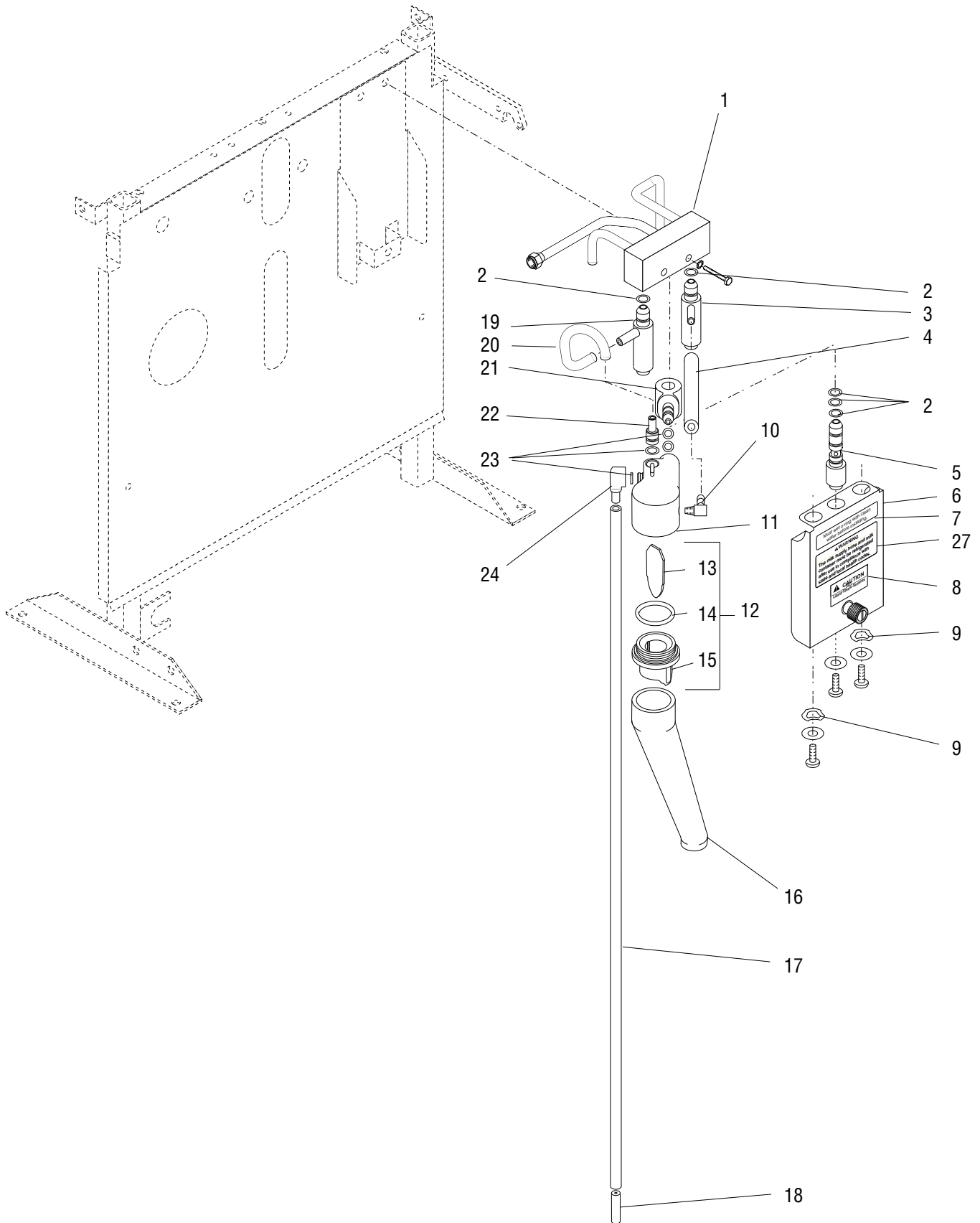

FROTHER MANIFOLD AND COMPONENTS

ITEM	PART NO.	QTY.	DESCRIPTION
1	26515.0001	1	Manifold, Frother - Plated
	24006.0003	2	Screw, Hex Head M5 x .80 x 30mm
	24026.0300	2	Lockwasher, External Tooth
2	24733.0000	5	O-Ring
3	26591.0001	1	Fitting, 2nd Steam - Plated
	02325.0000	1	Screw, Slotted Pan Head .25"-20 x .31"
	21431.0002	1	Washer, .286" I.D. x .625" O.D.
4	-----	1	Tube, Silicone .25" I.D. x .5" O.D. (Order item 25)
5	26516.0001	1	Fitting, Froth Steam - Plated
	02325.0000	1	Screw, Slotted Pan Head .25"-20 x .31"
	21431.0002	1	Washer, .286" I.D. x .625" O.D.
6	26742.0000	1	Slide Assembly, Outside (Includes items 7,8 & 27)
7	26625.0000	1	Decal, Wet O-Rings
8	24246.0000	1	Decal, Caution - Hot - Liquid-Steam-Surfaces
9	26562.0000	2	Washer, Spring .625" O.D.
10	00476.0001	1	Elbow, 90°, .25" Hose Barb x .312-24
11	24724.0001	1	Body, Venturi
12	24715.1001	1	Dispense Tube Assembly (Includes items 13 thru 15)
13	24722.0000	1	Focusing Laminator
14	24733.0002	1	O-Ring
15	24721.0001	1	Dispense Tube
16	25599.0000	1	Diverter, Frother
17	-----	1	Tube, Clear Vinyl .188" I.D. .312" O.D. x 24" LG (Order item 26)
18	24694.0000	1	Jet, Metering
19	26587.0001	1	Fitting, Air - Plated
	02325.0000	1	Screw, Slotted Pan Head .25"-20 x .31"
	21431.0002	1	Washer, .286" I.D. x .625" O.D.
20	-----	1	Tube, Clear Vinyl .188" I.D. x .312" O.D. x 3.2" LG (Order item 26)
21	24723.0000	1	Nozzle, Steam
22	25557.0000	1	Adapter, Air
23	24733.0001	4	O-Ring
24	24725.0000	1	Fitting, Tube
25	11707.1000	-	Tube, Silicone, .250" I.D. x .50" O.D. x 12" LG
	11707.1001	-	Tube, Silicone, .250" I.D. x .50" O.D. x 36" LG
	11707.1002	-	Tube, Silicone, .250" I.D. x .50" O.D. x 120" LG
26	23782.1001	-	Tube, Clear Vinyl .188" I.D. x .312" O.D. x 24" LG
27	26868.0000	1	Decal, Warning

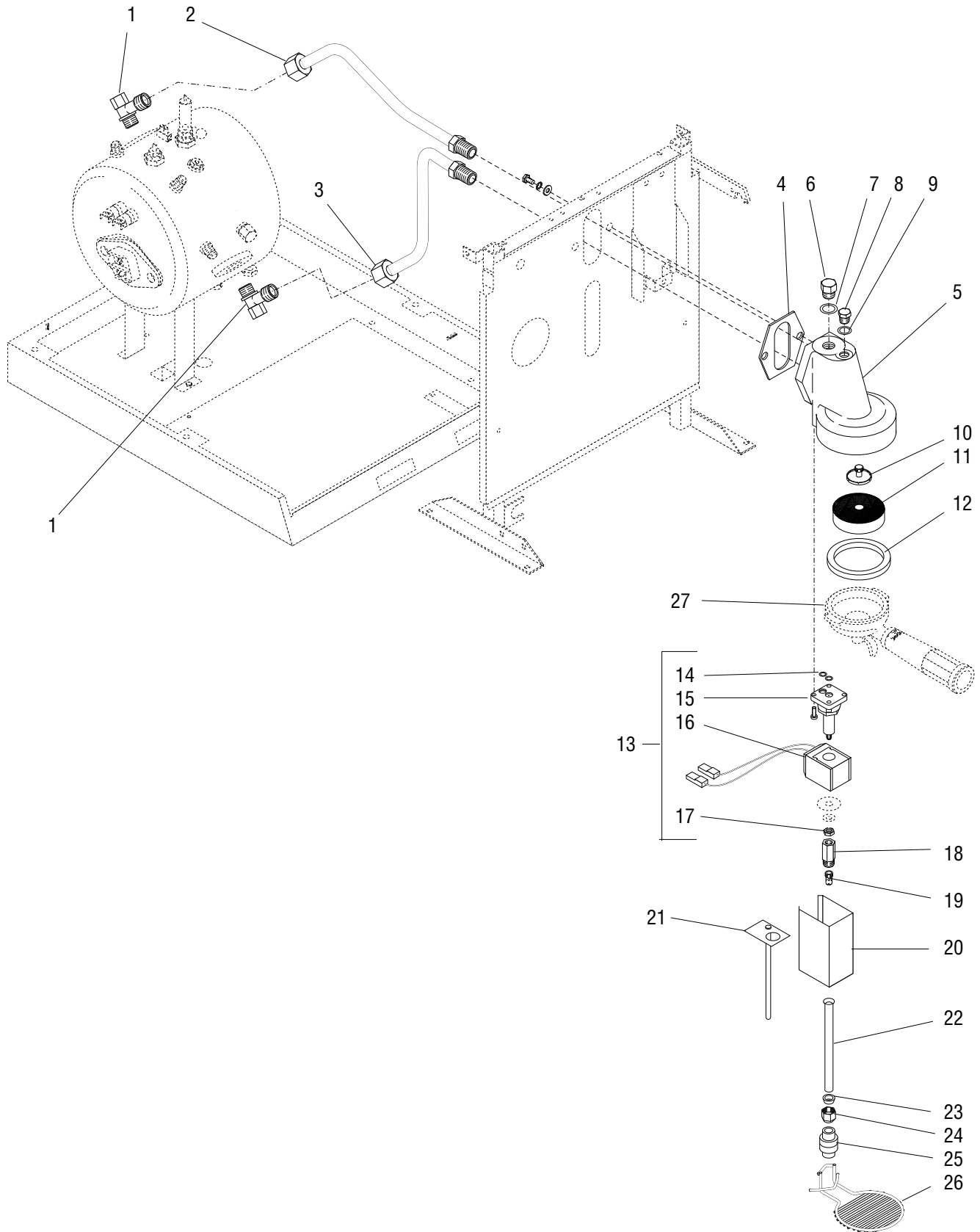

GROUP HEAD AND PIPING

ITEM	PART NO.	QTY.	DESCRIPTION
1	23609.0001	2	Fitting, Water - Plated
2	23612.0001	1	Tube Assembly, Tank to Group Head (Upper) - Plated
3	23621.0001	1	Tube Assembly, Tank to Group Head (Lower) - Plated
4	23584.0000	1	Gasket, Group Head to Front Cover
5	23641.0000	1	Group Head
	24008.0001	2	Screw, Hex Head M8 x 1.25 x 16mm
	24028.0300	2	Lockwasher, External Tooth M8
	24028.0000	2	Washer, Flat M8
6	23590.0000	1	Plug, M16 x 1.5 (Also order item 7)
7	22867.0000	1	Washer, Sealing
8	23591.0000	1	Plug, M12 x 1.25 (Also order item 9)
9	24030.0000	1	Washer, Sealing
10	23592.0001	1	Sprayhead - Plated
11	24747.0001	1	Screen Assembly, Pod Brewing
	23593.0000	1	Screen
12	23594.0000	1	Gasket, Filter Holder
13	23597.0001	1	Solenoid Assembly, 110V (Includes items 14 thru 17)
	24005.0300	4	Screw, Socket Head M4 x .7 x 12mm
14	23596.0000	2	O-Ring
15	-----	1	Base, Solenoid (Not Available. Order item 13)
16	23595.0000	1	Coil, 110V
17	24891.0000	1	Nut, M10 x 1.0
18	23583.0000	1	Fitting, Hex - Solenoid Discharge
19	23582.0000	1	Orifice, Solenoid Discharge
20	23642.0000	1	Cover, Solenoid
21	26657.0000	1	Stop, Cup Tray
22	21801.0000	1	Tube, .375" O.D. x 4.80" LG - Discharge
23	25598.0000	1	Ferrule, .375" O.D. Tube
24	23581.0000	1	Nut, Solenoid Discharge
25	25567.0000	1	Slide Assembly, Cup Tray
26	26484.0000	1	Tray, Cup
27	-----	1	Holder Assembly (See Filter and Cup Holder Assembly)

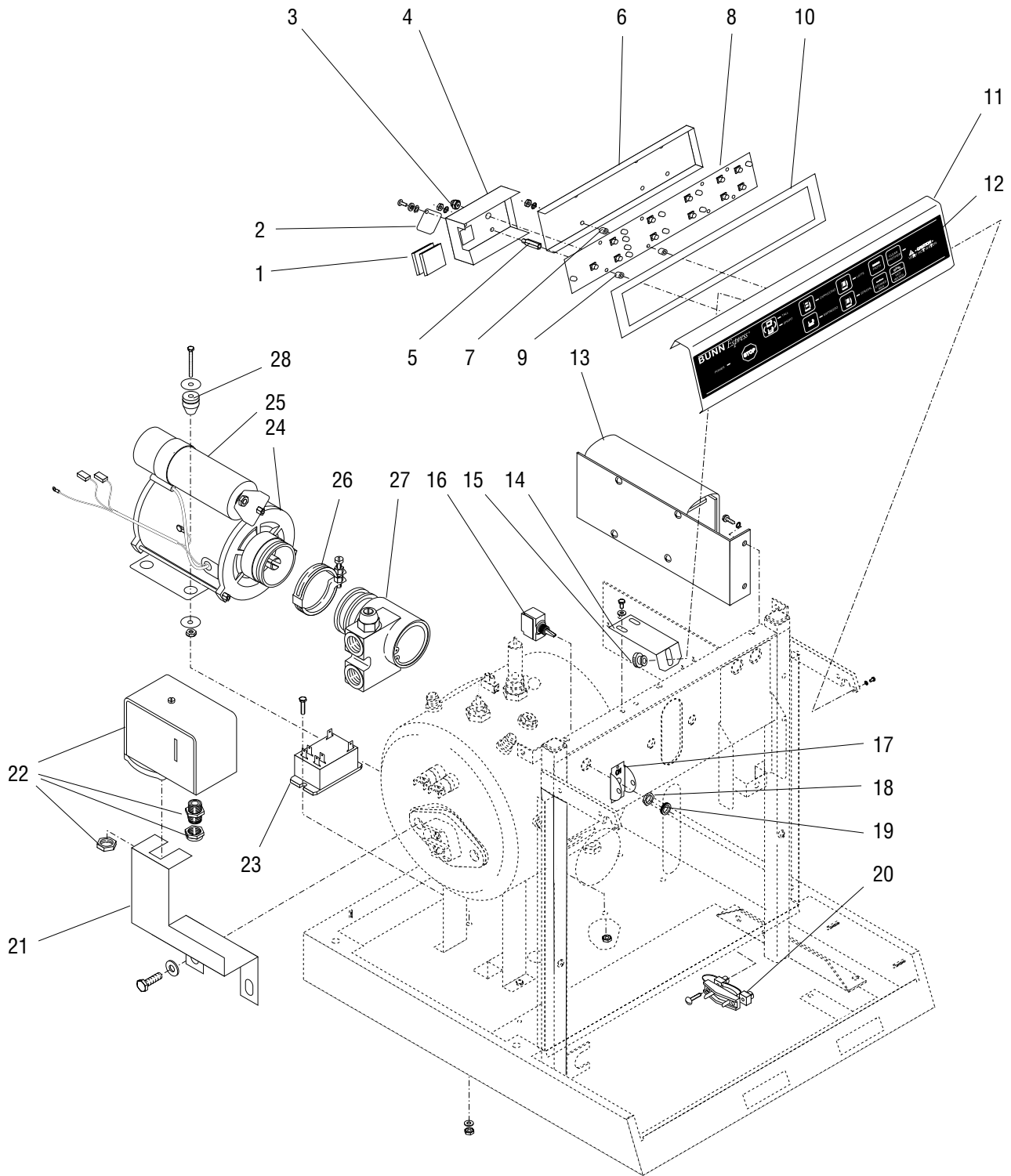

ELECTRICAL AND OPERATING CONTROLS

ITEM	PART NO.	QTY.	DESCRIPTION
1	23778.0000	2	Gasket, Switch Connection
2	25596.0000	1	Cover, Digital Brewer Display Assembly Receptacle
	02327.0002	1	Screw, Pan Head #4-40 x .312"
	26634.0000	1	Washer, Shoulder .125" I.D. x .375' O.D.
	26562.0001	1	Washer, Spring #4
3	26628.0000	1	Seal, Switch
4	25595.0000	1	Cover, PCB - Left
	01509.0000	2	Lockwasher, External Tooth #4
	00937.0000	2	Nut, Hex #4-40
5	23776.0002	2	Spacer, Hex Male-Female #4-40 x .625
6	25584.0000	1	Cover, PCB W/Decal - Right
	01509.0000	6	Lockwasher, External Tooth #4
	00937.0000	6	Nut, Hex #4-40
7	01533.0004	6	Spacer, Nylon .140" I.D. x .250" O.D. x .19" LG
8	25583.0000	1	PCB Assembly, LED
9	01533.0003	8	Spacer, Nylon .140" I.D. x .250" O.D. .31" LG
10	26624.0000	1	Gasket, PCB/LED Switch Cover
11	26744.0000	1	Panel, Control W/ Decal (Includes item 12)
	24005.0002	2	Screw, Hex Head M4 x .70 x 8mm
	24025.0301	2	Lockwasher, External Tooth M4
12	25551.0001	1	Decal, Control Panel - 10 Button
13	25468.0003	1	Board Assembly, Digital Brewer Control
	24006.0001	2	Screw, Hex Head M5 x .8 x 15mm
	24026.0300	2	Lockwasher, External Tooth M5
14	23652.0000	1	Bracket, Control Panel Mounting
	24005.0002	2	Screw, Hex Head M4 x .70 x 8mm
	24025.0301	2	Lockwasher, External Tooth, M4
	24025.0000	2	Washer, Flat M4
15	23542.0000	1	Thumb Nut, Control Panel
16	23522.0000	1	Switch, Toggle (Includes item 19)
17	25102.0000	1	Bracket, Switch Indicator/Guard
18	23696.0000	1	Nut, Hex
19	23697.0000	1	Facenut, Plastic
20	23635.0000	1	Clamp, Cable
	24004.0800	2	Screw, Pan Head Self Tapping M3.5 x 25mm
21	24352.0000	1	Bracket, Pressure Switch Mounting

(Continued)

(Continued)

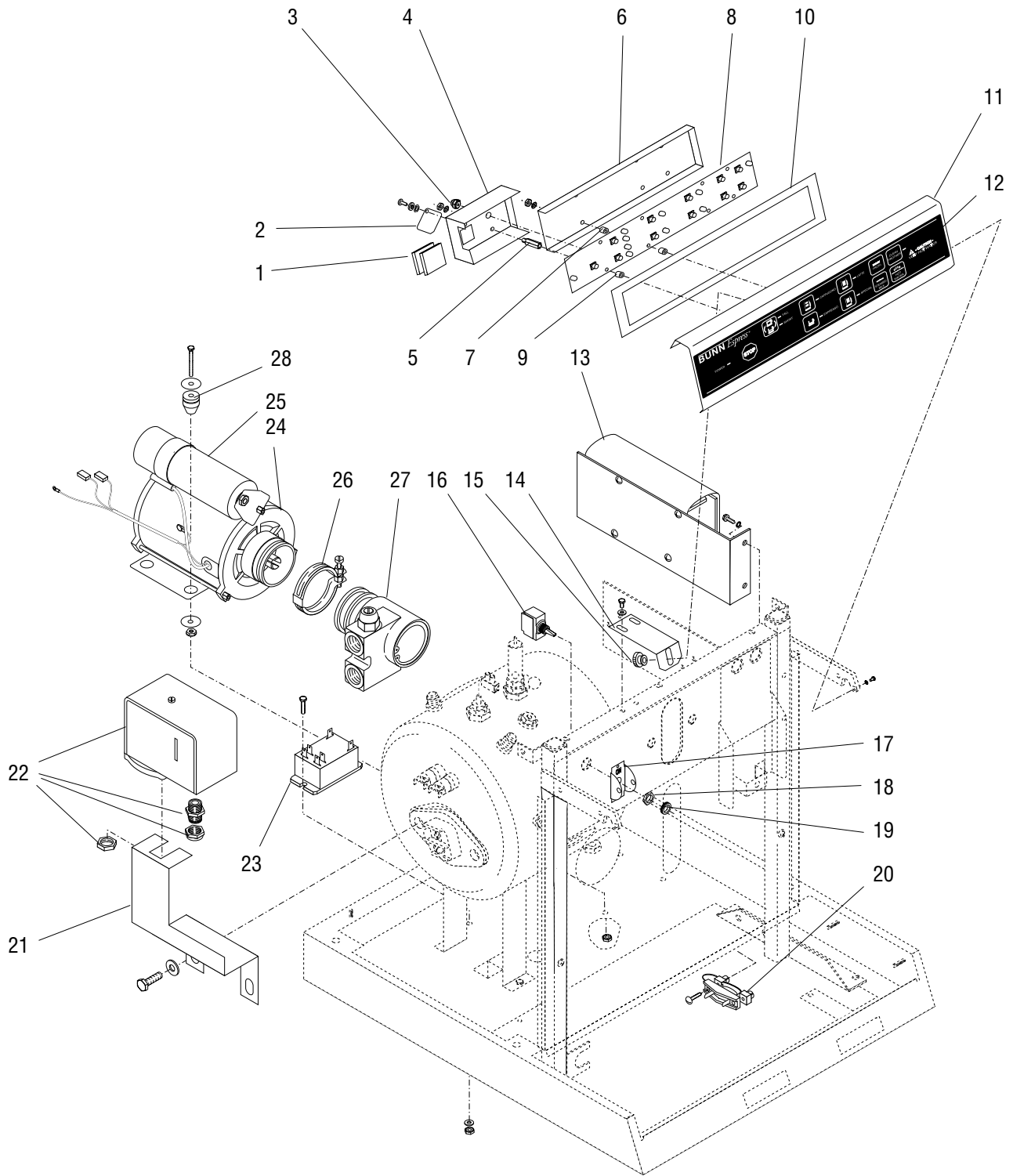

ELECTRICAL AND OPERATING CONTROLS

ITEM	PART NO.	QTY.	DESCRIPTION	
22	24851.0000	1	Switch Assembly, Pressure - Heater Control	
23	25948.0000	1	Relay, Tank Heater 120V	
	24006.0001	2	Screw, Hex Head M5 x .8 x 15mm	
	24026.0001	2	Washer, Flat M5	
	24046.0400	2	Nut, Hex Keps M5	
24	23664.0000	1	Motor Assembly 110V	
	24006.0003	4	Screw, Hex Head M5 x .80 x 30mm	
	24026.0002	8	Washer, Flat M5 x 20mm O.D.	
	24046.0400	8	Nut, Hex Keps M5	
25	23552.0000	1	Capacitor, Motor 110V	
26	23639.0000	1	Clamp, Pump Mounting	
27	25525.0001	1	Pump Assembly, Rotary	
28	26697.0000	4	Grommet, Motor Mount	
29	25654.0000	1	Digital Brewer Display Assembly	<div style="display: flex; align-items: center;"> <div style="border-left: 1px solid black; border-right: 1px solid black; border-top: 1px solid black; border-bottom: 1px solid black; width: 20px; height: 100px; margin-right: 5px;"></div> Not Illustrated </div>
30	25662.0002	1	Cord Assembly, Digital Brewer Display Assembly	
31	01638.0000	1	Cord, Power	
32	25580.0000	1	Wiring Harness, Heating Circuit	
33	25581.0000	1	Wiring Harness, Signal Input	
34	25582.0000	1	Wiring Harness, Signal Output	
35	23769.0000	1	Lead, BLK - Limit Thermostat to Limit Thermostat	

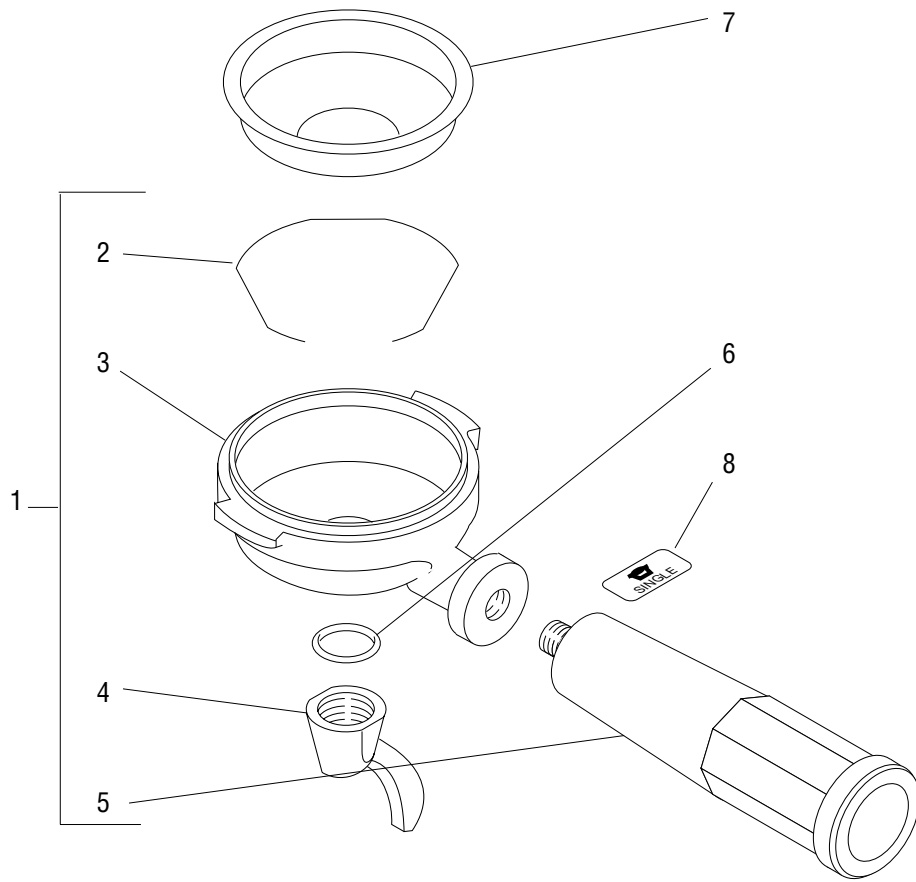

FILTER HOLDER ASSEMBLY

ITEM	PART NO.	QTY.	DESCRIPTION
-	23548.0001	1	Filter Holder Assembly - 1 Pod (Includes items 1, 6 thru 8)
-	23548.0002	1	Filter Holder Assembly - 2 Pod (Includes items 1, 6 thru 8)
1	23548.0000	1	Filter Holder Assembly (Includes items 2 Thru 5)
2	22819.0000	1	Wire, Filter Support
3	23632.0000	1	Holder, Filter
4	23547.0000	1	Nozzle, Dispense - 1 Cup
5	26745.0000	1	Handle, Filter (Includes item 8)
6	07011.0000	1	O-Ring
7	24493.0000	1	Filter, 1 Pod
	22710.0000	1	Filter, 2 Pod
8	26678.0000	1	Decal, Filter Handle - Single
	26678.0001	1	Decal, Filter Handle - Double
9	23544.0000	1	Cup, Pressure Test - No Holes (Not Illustrated)

NUMERICAL INDEX

PART NO.	PAGE NO.	PART NO.	PAGE NO.	PART NO.	PAGE NO.	PART NO.	PAGE NO.
00400.0001	15	22815.0000	7	23635.0000	23	24246.0000	19
00402.0001	15	22819.0000	27	23638.0000	3	24247.0000	5
00412.0000	15	22867.0000	21	23639.0000	25	24267.0000	13
00425.0000	15	22868.0000	7,11	23641.0000	21	24274.0000	7
00431.0001	17	22905.0001	9	23642.0000	21	24284.0000	13
00436.0001	9	23445.0001	5	23647.0001	7	24352.0000	25
00445.0001	9	23445.0002	5	23648.0000	3	24386.0000	9
00462.0001	15	23467.0001	3	23652.0000	23	24493.0000	27
00464.0001	15	23522.0000	23	23653.0000	3	24641.0000	11
00476.0001	19	23540.0001	9	23654.0000	3	24682.0000	9
00483.0000	17	23542.0000	23	23655.0001	3	24683.0000	9
00484.0001	15	23544.0000	27	23664.0000	25	24683.0001	9
00484.0003	15	23547.0000	27	23668.0000	3	24684.0000	9,19
00656.0000	5	23548.0000	27	23669.0000	3	24706.1000	15
00671.0000	3	23548.0001	27	23696.0000	23	24715.1001	19
00937.0000	23	23548.0002	27	23697.0000	23	24718.0000	15
00937.0000	23	23552.0000	25	23721.0000	9	24721.0001	19
00986.0002	5	23563.0001	11	23769.0000	25	24722.0000	19
01387.0000	3,5	23567.0001	11	23776.0002	23	24723.0000	19
01509.0000	23	23569.0001	11	23778.0000	23	24724.0001	19
01512.0000	15	23581.0000	21	23782.1001	17,19	24725.0000	19
01514.0000	9	23582.0000	21	23820.1000	9	24732.0000	15
01533.0003	23	23583.0000	21	23933.0000	9	24733.0000	19
01533.0004	23	23584.0000	21	23934.0000	7	24733.0001	15,19
01533.0005	15	23586.0000	7	24003.1000	3	24733.0002	19
01638.0000	25	23590.0000	21	24004.0800	23	24744.0000	9
02325.0000	19	23591.0000	21	24005.0002	5,15,23	24747.0001	21
02327.0002	23	23592.0001	21	24005.0200	3	24842.0000	3
02536.0000	7	23593.0000	21	24005.0300	21	24851.0000	25
03236.1001	11	23594.0000	21	24006.0001	7,23,25	24891.0000	21
03236.1001	11	23595.0000	21	24006.0001	23	25035.0000	7
03236.1002	11	23596.0000	21	24006.0003	19,25	25102.0000	23
03236.1003	11	23597.0001	21	24006.1000	3	25185.0000	7
03996.0000	3	23600.0001	7	24007.0000	3	25186.0000	7
07011.0000	27	23601.0001	7	24008.0001	21	25267.0000	9
11707.1000	17,19	23603.0000	7	24025.0000	23	25468.0003	23
11707.1001	17,19	23605.0001	7	24025.0301	23	25525.0001	25
11707.1002	17,19	23606.0001	7	24026.0001	7,25	25551.0001	23
12422.0000	15	23607.0000	7	24026.0002	25	25554.0000	3
12422.0004	11	23608.0000	7	24026.0300	19,23	25555.0000	5
12652.0000	5	23609.0001	21	24027.0000	3	25557.0000	19
12919.0003	3	23610.0001	9	24028.0000	21	25559.0000	3
13255.0003	5	23611.0000	13	24028.0300	21	25562.0000	7
21000.0524	11	23612.0001	21	24029.0000	7	25564.0000	15
21431.0002	19	23613.0000	13	24030.0000	21	25565.0000	15
21481.0000	15	23614.0000	11	24030.0001	7,15	25567.0000	21
21801.0000	21	23615.0000	11	24043.0400	3	25569.0001	15
21920.0000	11,15	23620.0000	11	24045.0101	3,11	25580.0000	25
22249.0000	9	23621.0001	21	24045.0101	11	25581.0000	25
22267.0002	9	23624.0001	11	24045.0400	5,7,25	25582.0000	25
22603.0000	11	23628.0000	7	24047.0400	3	25583.0000	23
22710.0000	27	23629.0000	7	24210.0000	13	25584.0000	23
22723.0000	3	23632.0000	27	24211.0000	13	25586.0000	17
22814.0000	7	23634.0000	11	24212.0000	13	25587.0000	9

NUMERICAL INDEX

PART NO.	PAGE NO.	PART NO.	PAGE NO.	PART NO.	PAGE NO.	PART NO.	PAGE NO.
25588.0000	15						
25596.0000	23						
25598.0000	21						
25599.0000	19						
25654.0000	25						
25662.0002	25						
25948.0000	25						
26196.0001	3						
26209.0000	7						
26484.0000	21						
26515.0001	19						
26516.0001	19						
26528.0000	3						
26562.0000	19						
26562.0001	23						
26564.0000	3						
26587.0001	19						
26591.0001	19						
26601.0000	3						
26602.0000	17						
26602.0001	17						
26624.0000	23						
26625.0000	19						
26627.0000	15						
26628.0000	23						
26634.0000	23						
26657.0000	21						
26678.0000	27						
26678.0001	27						
26682.0000	15						
26683.0000	15						
26697.0000	25						
26737.0000	3						
26738.0000	3						
26739.0000	3						
26740.0000	3						
26741.0000	5						
26742.0000	19						
26743.0000	23						
26744.0000	23						
26745.0000	27						
26746.0000	3						
26868.0000	19						

